

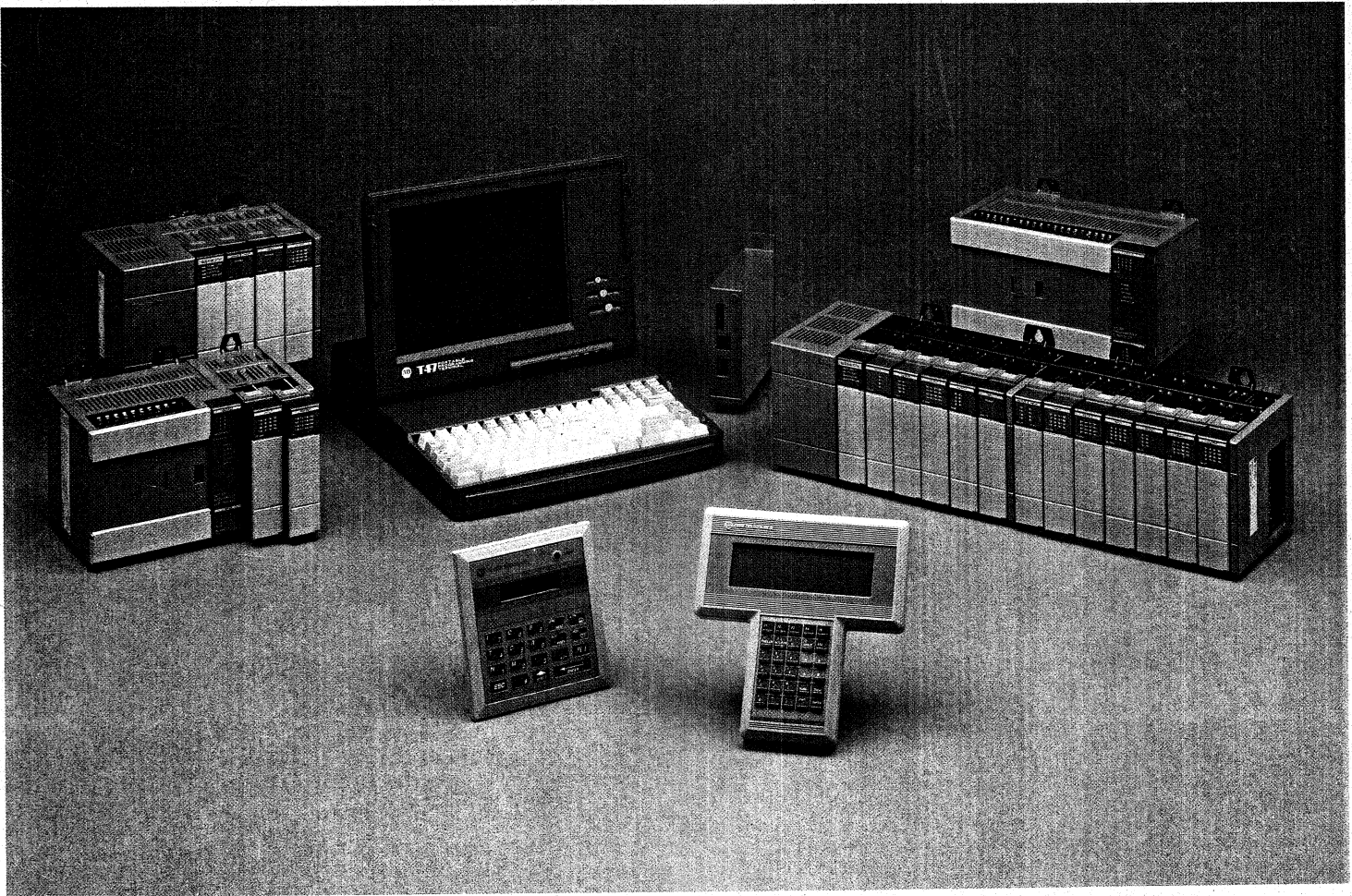

ALLEN-BRADLEY

## SLC 500 Family of Small Programmable Controllers

### System Overview



## The SLC 500 Family of Small Logic Controllers

The SLC 500 programmable controller surpasses simple machine control. Its powerful instruction set, advanced programming tools and expanded product capabilities give you all of the right reasons to use it for your next control application.

The SLC 500 line is a growing family of small programmable controllers built around two hardware options: The SLC 500 system can be configured as a fixed controller with an option to expand using a two-slot chassis, or as a modular I/O controller with up to 480 I/O points. Most I/O modules and programming tools are compatible between the two hardware options, so you can cost effectively solve a broad range of applications.

In addition to flexibility, SLC 500 programmable controllers communicate across an embedded DH-485 network allowing program support and monitoring. The SLC 1747-L524 5/02 processor provides peer-to-peer communications for supervisory control and diagnostics. For implementation of a distributed I/O system, any SLC 500 programmable controller used with the Direct Communications Module (DCM) integrates into Allen-Bradley's 1771 remote I/O network as an I/O drop.

As small programmable controller applications increase in complexity, the SLC 500 continues to broaden its capability by continuously introducing new products. The new 1746 analog I/O modules provide the highest resolution on the market and the combination modules let you control two loops while occupying a single slot in either hardware option. The Data Table Access Module (DTAM) provides a simple, cost effective operator interface into an SLC 500 controller or DH-485 network. This, in many cases, eliminates the need to provide a programmer for each programmable controller.

The following pages describe:

- A Typical System Configuration
- Fixed or Modular SLC 500 Programmable Controllers
- Discrete Input/Output Modules
- Analog I/O Modules
- IMC 110 Servo Positioning Module
- Programming and Networking Options
- Allen-Bradley Service and Support
- How to Configure a SLC 500 System

For your reference we provide:

- I/O Compatibility Chart
- SLC 500 Programming Instruction Set
- Input/Output Wiring Diagrams
- Dimensions for Fixed and Modular SLC 500 Controllers

## Typical System Configuration

Allen-Bradley 1784-T45, T47  
or compatible laptop

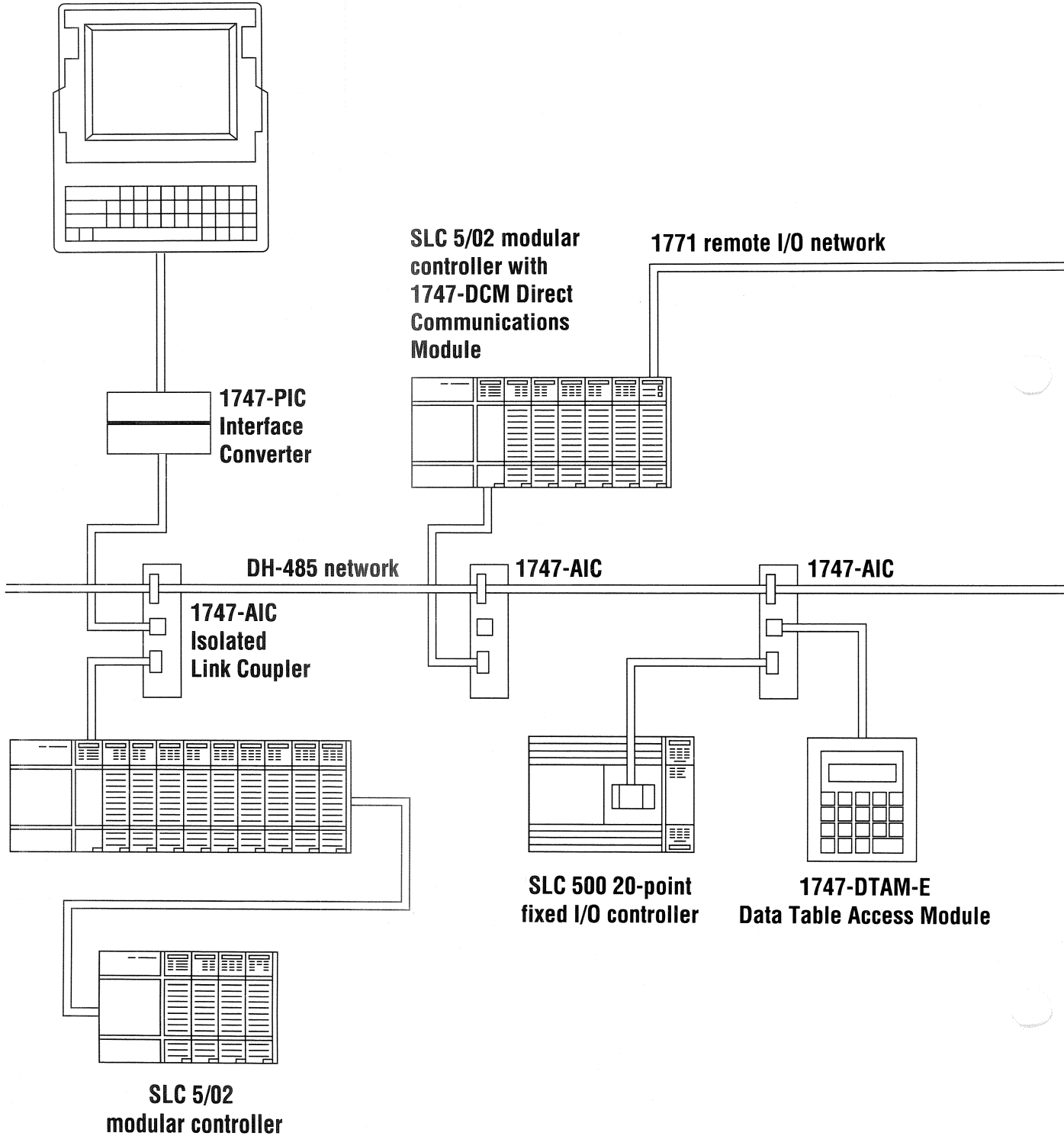

**System Overview**  
SLC 500 Family of Small  
Programmable Controllers

**DH+ network**

**PLC-5/15 or  
PLC-5/25**

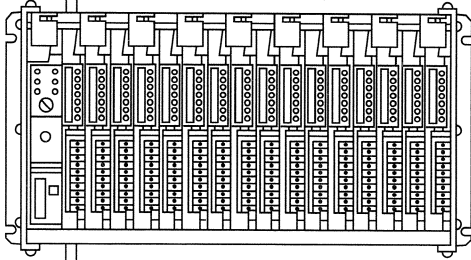

**IBM-PC XT, AT or compatible  
with 1784-KR, DH-485  
PC Interface**

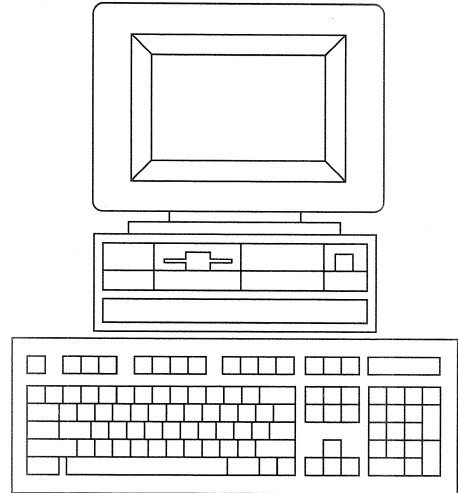

**SLC 500 fixed  
controller with  
expansion rack  
and 1747-DCM**

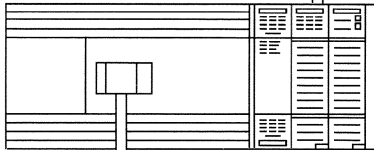

**DH-485 network**

**1747-AIC**

**1747-AIC**

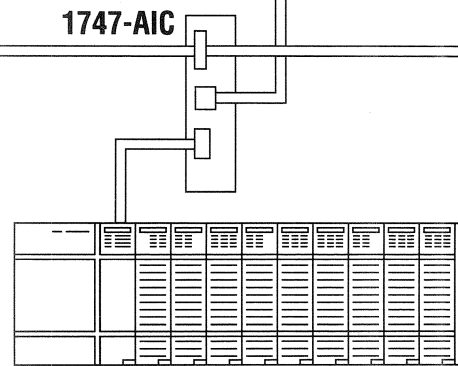
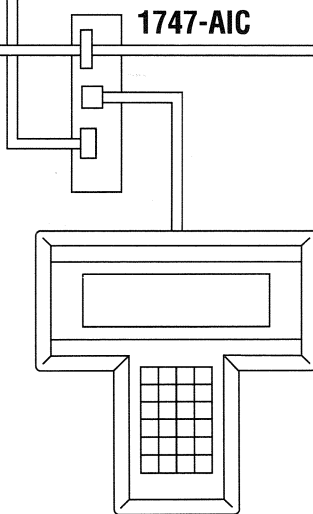

**SLC 5/01 modular controller**

**SLC 500  
Hand Held Terminal**

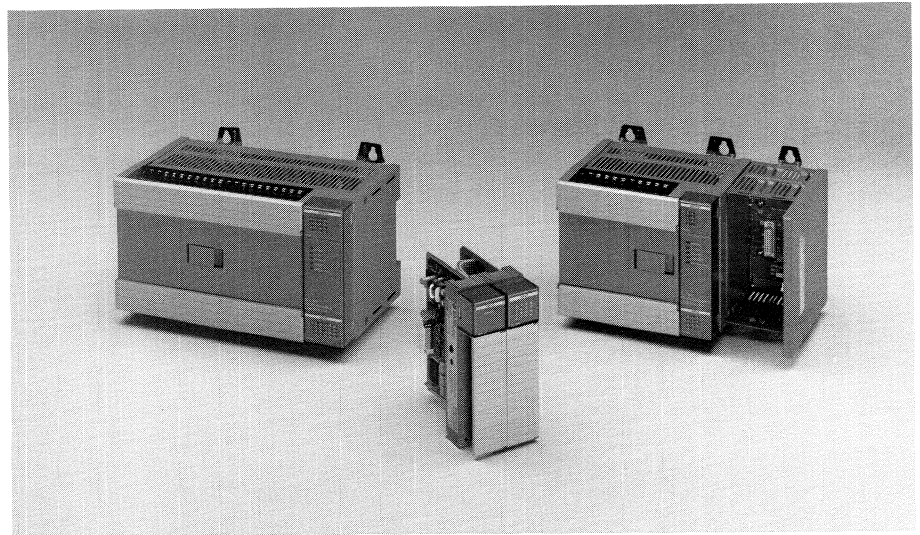

## 1747 SLC 500 Fixed Controller

The SLC 500 Fixed Controller offers a variety of low cost options with up to 72 Input/Output (I/O) points. This controller also offers enhanced networking capabilities and global power supply options.

The SLC 500 fixed controller includes a central processor unit (CPU) with DH-485 communications connectivity, a built-in power supply and a predefined number of I/O points.

Feature	Benefits
Three Configuration Options	20, 30, or 40 I/O with 24 different I/O configuration.
Program Memory	1K Instruction or 4K Data Word Capacity of RAM memory.
Optional 2 slot Expansion Chassis	Provides up to 32 additional points of I/O or an interface to specialty I/O modules.
Optional Back-up Memory	EEPROM or UV PROM memory available.
Available 24 Volt dc User Power	Eliminates the need for an external power supply.
DC Input Module	Optional 8kHz counter or normal dc input.

**SLC 500 Fixed Controller Specifications**

The following table provides general specifications for the fixed controller.

Program Memory	1000 Instruction Words
Memory Type	Capacitor-backed RAM
Typical Scan Time	8 ms/K
Hold-up Time (Load Dependent)	20ms to 700ms
Optional Back-up Battery Life	5 years
Power Requirement	50VA
Noise Immunity	NEMA Standard ICS 2-230
Ambient Temperature Rating Operating Storage	0 to +60° C (32° to 140° F) -40° to +85° C (-104° to 185° F)
Humidity Rating	5-95% (non-condensing)
Wire Size	#14 AWG to #24 (max.)
Certification	U.L. listed/CSA Approved

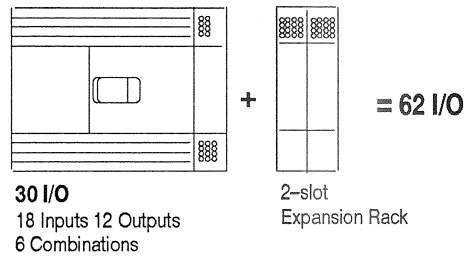
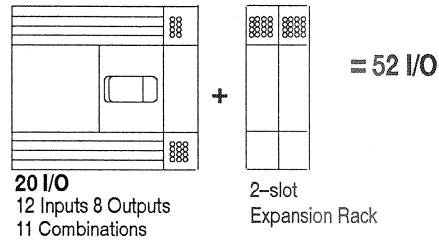

*All fixed controllers accept an optional two slot expansion rack that provides up to 32 additional I/O points.*

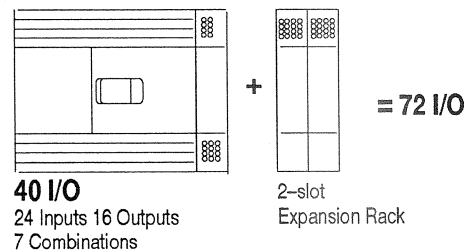

The following tables provide configuration options for 20, 30, or 40 I/O points. To aid you in configuring your system with additional modules, refer to the **Fixed Expansion Rack Compatibility chart on page 31.**

## 20 I/O Configuration

Catalog Number	Input	Output	Input Type	Output Type	Power Supply	High Speed Counter	User Power
1747-L20A	12	8	120 V ac	Relay	120/240V ac	No	-
1747-L20B				Triac	120/240V ac	No	-
1747-L20C			24 V dc Sinking	Relay	120/240V ac	Yes	24V-200mA
1747-L20D				Triac	120/240V ac	Yes	24V-200mA
1747-L20E				Transistor Source	120/240V ac	Yes	24V-200mA
1747-L20F				Relay	24V dc	Yes	-
1747-L20G				Transistor Source	24V dc	Yes	-
1747-L20L				24 V dc Sourcing	Transistor Sink	120/240V ac	Yes
1747-L20N			Transistor Sink		24V dc	Yes	-
1747-L20P			240 V ac	Triac	120/240V ac	No	-
1747-L20R				Relay	120/240V ac	No	-

## 30 I/O Configuration

Catalog Number	Input	Output	Input Type	Output Type	Power Supply	High Speed Counter	User Power
1747-L30A	18	12	120 V ac	Relay	120/240V ac	No	-
1747-L30B				Triac	120/240V ac	No	-
1747-L30C			24 V dc Sinking	Relay	120/240V ac	Yes	24V-200mA
1747-L30D				Triac	120/240V ac	Yes	24V-200mA
1747-L30L			24 V dc Sourcing	Transistor Sink	120/240V ac	Yes	24V-200mA
1747-L30P			240 V ac	Triac	120/240V ac	No	-

## 40 I/O Configuration

Catalog Number	Input	Output	Input Type	Output Type	Power Supply	High Speed Counter	User Power
1747-L40A	24	16	120 V ac	Relay	120/240V ac	No	-
1747-L40B				Triac	120/240V ac	No	-
1747-L40C			24 V dc Sinking	Relay	120/240V ac	Yes	24V-200mA
1747-L40E				Transistor Source	120/240V ac	Yes	24V-200mA
1747-L40F				Relay	24V dc	Yes	24V-200mA
1747-L40L			24 V dc Sourcing	Transistor Sink	120/240V ac	Yes	24V-200mA
1747-L40P			240 V ac	Triac	120/240V ac	No	-

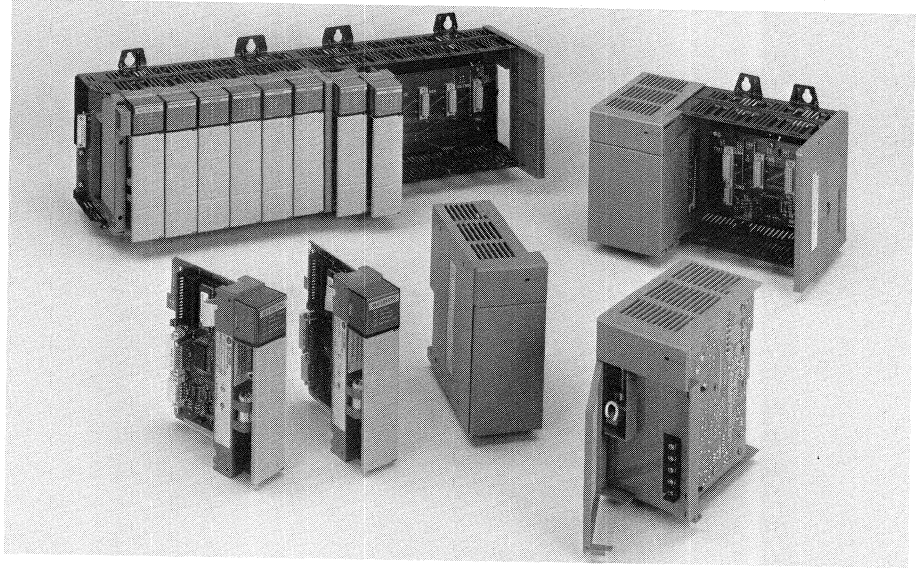

## 1747 SLC 500 Modular Controller

The 1747 SLC 500 Modular Controller offers additional flexibility in system configuration, more processing power and I/O capacity beyond the fixed controller. By selecting the appropriate modular rack, power supply, processor and discrete or specialty I/O modules, you can create a controller system specifically designed for your application.

Processor options include the SLC 5/01, (Catalog Number 1747-L511 and 1747-L514) 1K or 4K processor with an instruction set identical to the SLC 500 fixed controllers, and the SLC 5/02 (1747-L524) 4K processor with an enhanced programming instruction set.

The SLC 500 modular controller consists of a variety of CPUs, power supplies, chassis and discrete and specialty I/O modules.

Feature	Benefit
3 Central Processing Units	Supports a variety of I/O requirements and functionality.
4 Different Chassis Sizes	Provides I/O mounting flexibility and expansion options.
1746 I/O	Provides over 25 different modules to meet your application needs.
3 Power Supplies	Supports AC and DC power, providing 3 different sizes.

### **SLC 5/01 (1747-L511 and 1747-L514)**

The SLC 5/01 processors offer the instruction set of the SLC 500 fixed controller in a modular hardware configuration. The SLC 5/01 provides:

- Program memory options of 1K or 4K (4K or 16K data words respectively)
- Addressing of up to 256 I/O
- DH-485 communications
- Ladder logic programming
- Advanced programming instructions including:
  - Integer Math Instructions – Add, Subtract, Multiply, Divide and Double Divide
  - Compare and Move instructions
  - Sequencer Output and Sequencer Compare instructions
- Programmed using IBM based Advanced Programming Software (APS) or the Hand-Held Terminal (HHT)
- U.L. listed/CSA Approved

### **SLC 5/02 (1747-L524)**

The SLC 5/02 processor offers an enhanced instruction set, increased diagnostic capabilities and expanded communication capabilities beyond the 5/01 and fixed controllers. In addition to the 5/01 features, the 5/02 provides:

- 4K program memory (16K data words)
- DH-485 peer-to-peer communications
- Advanced Instructions including:
  - Interrupts
  - Embedded PID instruction
  - Indexed Addressing
  - User written error routines
  - Message Instruction
- U.L. listed/CSA Approved

The following table describes the general specifications for the SLC 5/01, (Catalog Number 1747-L511 and 1747-L514) and the 5/02 (1747-L524) processor.

Catalog Number	5/01 (1747-L511)	5/01 (1747-L514)	5/02 (1747-L524)
Program Memory	1K Instruction or 4K Data Words	4K Instruction or 16K Data Words	4K Instruction or 16K Data Words
I/O Capacity	256 Discrete	256 Discrete	480 Discrete
Max. Racks or Slots	3/30	3/30	3/30
Standard RAM Memory Back-up or Life	Capacitor 48 hours Optional Lithium Battery – 5 years	Lithium Battery 2 years	Lithium Battery 2 years
Memory Back-up Options	EEPROM or UVPROM	EEPROM or UVPROM	EEPROM or UVPROM
LED Indicators	Run, CPU Fault, Forced I/O, Battery Low	Run, CPU Fault, Forced I/O, Battery Low	Run, CPU Fault, Forced I/O, Battery Low, COMM
Programming	APS or HHT	APS or HHT	APS or HHT
Typical Scan Time	8 ms/K	8 ms/K	8 ms/K
Bit Execution (XIC)	4 microseconds	4 microseconds	4 microseconds
Communication	DH-485 receive	DH-485 receive	DH-485 receive or initiate
Certification	U.L listed/ CSA Approved	U.L listed/ CSA Approved	U.L listed/CSA Approved

**The Programming Instructions are available on pages 32–36 for your reference.**

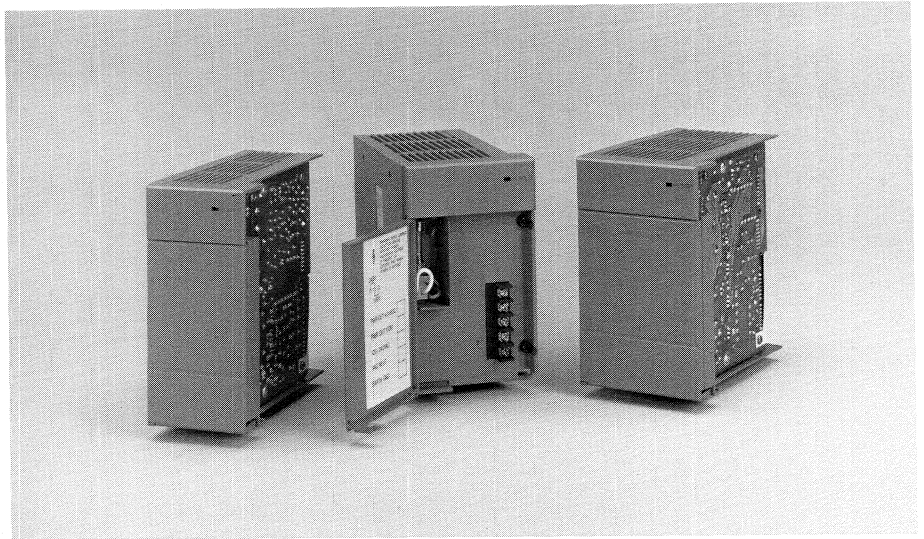

## Power Supply Options

Allen-Bradley offers three different power supplies, two ac and one 24 Volt dc. The ac supplies can be configured to operate using 120 or 240 Volt dc.

<b>POWER SUPPLIES</b>			
<b>Description</b>	<b>Catalog Number 1746-P1</b>	<b>Catalog Number 1746-P2</b>	<b>Catalog Number 1746-P3</b>
Line Voltage	85-132/170-265 V ac 50/60 kHz	85-132/170-265 V ac 50/60 kHz	19.2-28.8 V dc
Typical Line Power Requirement	135VA	180VA	90VA
Backplane Current Capacity (at 55°)	2 Amps at 5 Volts dc 0.46 Amps at 24 Volts dc	5 Amps at 5 Volts dc 0.96 Amps at 24 Volts dc	3.6 Amps at 5 Volts dc 0.87 Amps at 24 Volts dc
User Power	.2 Amps at 24 V dc	.2 Amps at 24 V dc	NA
Hold-up Time (Load Dependent)	20ms to 3000ms	20ms to 3000ms	20ms to 3000ms
Fuse Protection	3 Amps	3 Amps	5 Amps
Ambient Operating Temperature Range	0 to + 60° C (32° to 140° F) (Current capacity derated by 5% at 60° C)		
Wiring	#14 AWG (max.)		

## Discrete I/O Modules

The 1746 I/O platform is a modular hardware design which uses a cost and space effective means to add I/O modules to your control system. As a family of I/O modules, the 1746 I/O provides a platform from which the SLC 500 will continue to grow in the future.

Feature	Benefit
Hardware Platform sharing 4, 8, and 16 point modules	Makes spare parts stocking convenient. Creates a variety of choices for cost effective control solutions.
Combination Modules	Provides expansion capabilities without sacrificing space or cost.
Variety of Voltages	Creates a precise power fit for your application.

### Environmental Specifications for Discrete I/O Modules

Operating Temperature	0 to 60° C (32° to 140° F)
Storage Temperature	-40° to 85° C (-104° to +185° F)
Humidity	5 - 95% (non-condensing)

## 1746 Discrete Input Modules

Type	Voltage Category		Operating Voltage	Number of Outputs	Catalog Number 1746-	Backplane Current Draw		Signal Delay (ms. max)	Off State Voltage (max.)	Off State Current (max.)	Nominal Input Current	Points Per Common
						5 V	24 V					
ac	100/120		85-132	4	IA4	0.035	0	on=35 off=45	30 V ac	2 mA	12 mA	4
			85-132	8	IA8	0.050	0	on=35 off=45	30 V ac	2 mA	12 mA	8
			85-132	16	IA16	0.085	0	on=35 off=45	30 V ac	2mA	12 mA	16
	200/240		170-265	4	IM4	0.035	0	on=35 off=45	50 V ac	2mA	12 mA	4
			170-265	8	IM8	0.050	0	on=35 off=45	50 V ac	2mA	12 mA	8
			170-265	16	IM16	0.085	0	on=35 off=45	50 V ac	2mA	12 mA	16
dc	24		10-30 sink	8	IB8	0.050	0	on=8 off=8	5 V dc	1 mA	8 mA	8
			10-30 sink	16	IB16	0.085	0	on=8 off=8	5 V dc	1 mA	8 mA	16
			10-30 source	8	IV8	0.085	0	on=8 off=8	5 V dc	1 mA	8 mA	8
			10-30 source	16	IV16	0.085	0	on=8 off=8	5 V dc	1 mA	8 mA	16
	5	TTL		4.5-5.5 source	16	IG16	0.140	0	on=.25 off=.50	5.5 V dc	4.1mA	3.7mA

### 1746 Discrete Output Modules

Type	Voltage Category	Operating Voltage	Number of Outputs	Catalog Number 1746-	Backplane Current Draw		Signal Delay (ms. max)	Off State Leakage (max.)	Load Current (min.)	Continuous Current per point	Continuous Current per module	Points Per Common	
					5 V	24 V							
ac	120/240	85-265	8	OA8	0.185	0	on=0.10 off=11.0	2mA	10mA	1A at 30° C 0.50 at 60° C	8 at 30° C 4 at 60° C	8	
		85-265	16	OA16	0.370	0	on=0.10 off=11.0	2mA	10mA	0.50 at 30° C 0.25 at 60° C	8 at 30° C 4 at 60° C	16	
dc	24	10-50 source	8	OB8	0.135	0	on=0.10 off=1.0	1mA	1mA	1A at 30° C 0.50 at 60° C	8 at 30° C 4 at 60° C	8	
		10-50 sink	8	OV8	0.135	0	on=0.10 off=1.0	1mA	1mA	1A at 30° C 0.50 at 60° C	8 at 30° C 4 at 60° C	8	
		10-50 sink	16	OV16	0.270	0	on=0.10 off=1.0	1mA	1mA	0.50 at 30° C 0.25 at 60° C	8 at 30° C 4 at 60° C	16	
	5	TTL	4.5-5.5 sink	16	OG16	0.180	0	on=0.50 off=0.50	1mA	0.15mA	24mA	NA	16
ac/dc Relay			5-265 V ac 5-138 V dc	4	OW4	0.045	0.045	on=10.0 off=10.0	0mA	0	2.0A	8.0A	4
			5-265 V ac 5-138 V dc	8	OW8	0.085	0.090	on=10.0 off=10.0	0mA	0	2.0A	16.0A	8
			5-265 V ac 5-138 V dc	16	OW16	0.170	0.180	on=10.0 off=10.0	0mA	0	2.0A	16.0A 8.0A/common	8

Relay Contact Ratings for OW4, OW8, and OW16	Maximum Volts	Amperes		Amperes Continuous	Voltamperes	
		Make	Break		Make	Break
	240 V ac 120 V ac	7.5A 1.5A	0.75A 1.5A	2.0A	1800VA	180VA
125 V dc	0.22A		1.0A	28 VA		
24 V dc	1.2A		2.0A	28 VA		

### 1746 Discrete Combination Modules

Type	Voltage Category	Operating Voltage	Points Per Common	Points Per Module	Catalog Number 1746-	Backplane Current Draw		Specification Reference
						5V	24V	
Combo	Inputs-120 V ac	85-132 V ac	2	2 inputs 2 outputs	IO4	0.080	0.025	See specifications for Catalog Numbers 1746-IA4 and 1746-OW4
	Outputs Relay 100/120 V ac	5-265 V ac 5-125 V dc	4	4 inputs 4 outputs	IO8	0.060	0.045	Continuous Current for IO4 is 4.0A
			6	6 inputs 6 outputs	IO12	0.090	0.70	See specifications for Catalog Numbers 1746-IA16 and OW16 Continuous Current for IO12 is 12.0A

## Specialty I/O Modules

The SLC 500 family offers specialty I/O modules which enhance your control system. These modules range from analog, motion control and communication which provide a unique, easy to use interface between the modules and the CPU. Further information on these modules is available on pages 21–23.

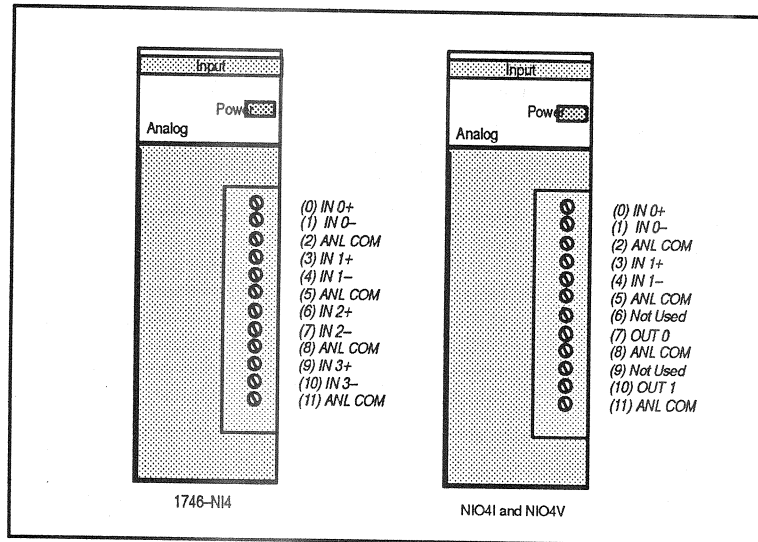

## Analog I/O Modules

The SLC 500 family currently offers one analog input module and two different combination modules to provide a more cost effective solution for your analog control. These modules use a 16-bit converter for high resolution and like the discrete I/O modules, the analog modules map their I/O data directly into the I/O image table of any SLC 500 CPU.

### 1746-NI4 Analog Input Module

The 1746-NI4 Analog Input module contains 4 analog input channels that are user selectable per channel for voltage or current to support a variety of monitoring and controlling applications.

### 1746-NIO4I and NIO4V Analog Combination Modules

The NIO4I and NIO4V Analog Combination I/O modules provide two input and two output channels in a single slot module. The 1746-NIO4I module contains two user selectable per channel, current or voltage inputs and two current outputs. The 1746-NIO4V module contains two current or voltage inputs and two voltage outputs.

**Analog I/O Modules (Continued)**

The following table describes a few of the features of the 1746 analog modules.

Feature	Benefit
High Resolution	Provide accurate control to serve a broad range of analog applications.
Backplane Powered	No external power supply required, reducing system cost.
User Selectable Inputs	Configurable per channel for current or voltage inputs.

The following tables provide general and specific specifications for the NI4, NIO4I, and NIO4V analog modules.

**General Specifications**

	NI4	NIO4I	NIO4V
SLC Communication Format	16 Bit Two's Complement Binary	16 Bit Two's Complement Binary	16 Bit Two's Complement Binary
Field Wiring to Backplane Isolation	500 Volts dc	500 Volts dc	500 Volts dc
Update Time	512 $\mu$ s. for all channels in parallel	512 $\mu$ s. for all channels in parallel	512 $\mu$ s. for all channels in parallel
Environmental Conditions			
Operating Temperature	0 to +60° C (32° to +140° F)	0 to +60° C (32° to +140° F)	0 to +60° C (32° to +140° F)
Storage Temperature	-40° C to +85° C (-104° F to 185° F)	-40° C to +85° C (-104° F to 185° F)	-40° C to +85° C (-104° F to 185° F)
Relative Humidity	5-95% Non-Condensing	5-95% Non-Condensing	5-95% Non-Condensing
Recommended Cable	Belden #8761	Belden #8761	Belden #8761
Maximum Wire Size	#14 AWG	#14 AWG	#14 AWG
Input Channels per Module	4 differential, voltage or current selectable per channel	2 differential, voltage or current selectable per channel	2 differential, voltage or current selectable per channel
Output Channels per Module	NA	2 current outputs, not individually isolated	2 voltage outputs, not individually isolated
Backplane Power Draw	25mA at 5 Volts dc 100mA at 24 Volts dc	40mA at 5 Volts dc 177mA at 24 Volts dc	40mA at 5 Volts dc 177mA at 24 Volts dc

### Current Input

	<b>NI4</b>	<b>NI04I</b>	<b>NI04V</b>
Input Range (Normal Operation)	±20mA	±20mA	±20mA
Input Impedance	250 Ohms	250 Ohms	250 Ohms
Conversion Method	Delta-Sigma Modulation	Delta-Sigma Modulation	Delta-Sigma Modulation
Resolution	1.22077µA per LSB	1.22077µA per LSB	1.22077µA per LSB
Absolute Max. Input Current	±30mA	±30mA	±30mA
Absolute Max. Input Voltage	±7.5V dc or 7.5V ac RMS	±7.5V dc or 7.5V ac RMS	±7.5V dc or 7.5V ac RMS
Overall Accuracy (0 to +60° C maximum)	±0.642% of full scale	±0.642% of full scale	±0.642% of full scale
Overall Accuracy Drift (maximum)	±79ppm/° C of full scale	±79ppm/° C of full scale	±79ppm/° C of full scale
Step Response	60 msec. (at 95%)	60 msec. (at 95%)	60 msec. (at 95%)

### Voltage Input

	<b>NI4</b>	<b>NI04I</b>	<b>NI04V</b>
Input Range	±10V dc	±10V dc	±10V dc
Input Impedance	1Mohm	1Mohm	1Mohm
Conversion Method	Delta-Sigma Modulation	Delta-Sigma Modulation	Delta-Sigma Modulation
Resolution	305.176µV per LSB	305.176µV per LSB	305.176µV per LSB
Overall Accuracy (0 to +60° C maximum)	±0.504% of full scale	±0.504% of full scale	±0.504% of full scale
Common Mode Voltage Range	±20 Volts dc	±20 Volts dc	±20 Volts dc
Overall Accuracy Drift (maximum)	±63ppm/° C of full scale	±63ppm/° C of full scale	±63ppm/° C of full scale
Step Response	60 msec. (at 95%)	60 msec. (at 95%)	60 msec. (at 95%)

### Current Output

	<b>NI4</b>	<b>NI04I</b>	<b>NI04V</b>
Output Range (Normal)	NA	0 to +20mA	NA
Resolution	NA	2.56348µA per LSB	NA
Overall Accuracy (0 to +60° C maximum)	NA	±0.541% of full scale	NA
Overall Accuracy Drift (maximum)	NA	±70ppm/° C of full scale	NA
Max. Load Reactance	NA	100µH	NA

### Voltage Output

	<b>NI4</b>	<b>NI04I</b>	<b>NI04V</b>
Input Range (Normal)	NA	NA	±10V dc
Resolution	NA	NA	1.22070mV per LSB
Overall Accuracy (0 to +60° C maximum)	NA	NA	±0.384% of full scale
Overall Accuracy Drift (maximum)	NA	NA	±54ppm/° C of full scale
Max. Load Reactance	NA	NA	1µF

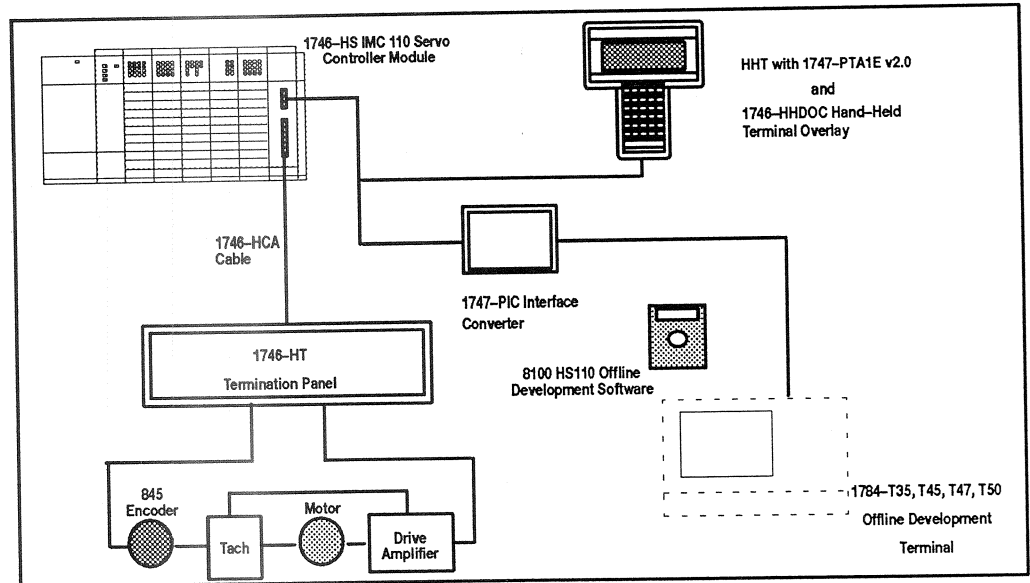

## 1746-HS IMC 110 Servo Positioning Module

The IMC 110 Motion Control System is a single-axis closed loop servo positioning module that plugs into a single slot of the SLC 500 programmable controller. When used with Allen-Bradley's advanced configuration tools, servo drives, motors and encoders, the IMC 110 becomes the key component of a low cost and powerful motion control system.

The IMC 110 replaces mechanical methods of controlling machine speed and position. The IMC 110 directs the movement of a single axis, or shaft, through a preprogrammed sequencer while monitoring an encoder for position feedback.

Feature	Benefit
4 Fast I/O points	Controlled by the IMC 110 system, saving valuable throughput time.
Encoder feedback compatibility	Provides an interface to both a 5 Volt or 15 Volt differential encoder.
±10 Volt dc Signal	Provides an interface to most servo drives.
5 msec Servo Loop Closure Rate	Provides a high degree of accuracy and system response.
SLC 500 Interface	Supports either an SLC 500 fixed or modular system.
Termination Panel Interface	Provides a wiring connection for fast I/O, E-stop, power supplies, drive command and encoder feedback.

**Programming Capabilities**

**High Level Motion Management Language (MML)** is an offline IBM compatible development software package. It is used to program and debug motion application programs using simple English-like statements.

**Graphical Motion Control Language (GML)** runs on a Macintosh computer and provides a graphical user interface using icons connected in a block diagram format.

**1747-PTA1E Memory Pak v2.0** or greater provides a portable means to operate, test, and trouble-shoot your motion control system.

**IMC 110 Specifications**

The following table provides general specifications for the IMC 110 Servo Positioning Module.

Number of Controlled Axes	1 per motion module
Axis Type	Linear or rotary (selectable)
Operating Temperature	0 to +60° C (32° to 140° F)
Backplane Current Draw	0.36A at 5.0 V dc
Acceleration and Deceleration	Rectangular
User Memory	12K bytes
Memory Back-up	Capacitor with 11 to 31 days (temp. dependent)
Velocity Command	Output voltage $\pm 10$ V dc resolution 11 bits plus sign (4.88 mV per bit)
Encoder Feedback	Single encoder feedback Encoder (845H) gated marker Encoder frequency 200 kHz
Emergency Stop Interface	Provision for user defined hardware circuit or device



## Programming Options

The following section describes two types of programming options available to the SLC 500. The first is the 1747-PA2E Advanced Programming Software (APS) and the second is the Hand-Held Terminal (HHT) which consists of the 1747-PT1 and the 1747-PTA1E memory pak.

### 1747-PA2E Advanced Programming Software

The Advanced Programming Software (APS) v2.01 enables you to program the SLC 500 family processors using the Allen-Bradley T50 Industrial Terminal, T45 and T47 Portable Terminals, or IBM-AT, XT or compatible personal computer. The software is in color which allows for easy viewing.

Feature	Benefit
Full-line Processor Support	Programs any SLC 500 processor and the 5/01 and 5/02 modular processors.
DH-485 Network Support	Enables the software to communicate with any of up to 30 SLC 500 processors.
Cut, Copy, Paste Editor	Permits ladder logic to be re-used.
Search and Replace	Allows quick modification of ladder logic to match unforeseen hardware changes.
Data Table Contents Report	Provides a hardcopy of the different data tables.
PROM Translator	Converts APS created program files into a form compatible with PROM programmers.
Network Diagnostics	Checks the operation of the DH-485 network.

**1747-PA2E**  
**Advanced Programming Software**  
**(Continued)**

**System requirements for APS:**

- 640K bytes of RAM
- 20M hard drive (minimum)
- DOS version 3.x
- Monochrome or Color Monitor (CGA, EGA, VGA)

**1747-PIC**  
**Interface Converter**

An RS-232 to DH-485 Interface Converter is required to establish communication between a personal computer and an SLC controller. The interface converter can also establish communication between a personal computer and the DH-485 network. The RS-232 signal levels at your personal computer are converted to DH-485 signal levels for the SLC 500 controller. The converter includes an 11 inch (279.4mm) 25 pin ribbon cable for connection to the computer and a cable (Catalog Number 1746-C10) for connection to the SLC 500 controller.

**1747-PT1 Hand-Held Terminal and  
 1747-PTA1E Programming  
 Memory Pak**

The Hand-Held Terminal (HHT) v2.0 is a powerful portable programming platform used to configure any SLC 500 controller, enter or modify an application program, monitor the execution of the application program in real-time, or troubleshoot an application program. The programming memory pak is interchangeable and available in six languages. When used with the memory pak (v2.0), the HHT can program the SLC 5/02 CPU as well as connect to the DH-485 network.

<b>Feature</b>	<b>Benefit</b>
Full-line Processor Support	Programs any SLC 500 processor and the SLC 5/01 and 5/02 modular processors.
Rugged Construction	Designed for a variety of industrial environments.
Menu-driven Firmware	Displays step-by-step directions.
LCD Display	Shows up to 5 rungs of ladder logic at one time.
Network Diagnostics	Checks the operation of the DH-485 network (v2.0).
ZOOM Function	Displays a detailed instruction set.
Formatted Display	Displays PID and MSG instructions (v2.0).

**1747-PT1 Hand-Held Terminal Specifications**

The following table provides general specifications for the HHT.

Display	8 line x 40 character super-twist nematic LCD
Ambient Temperature Rating Operating Storage	0 to +40° C (32° to +104° F) -20° to +65° C (-4° to +149° F)
Humidity Rating	5-95% (without condensation)
Keyboard	30 keys
Operating Power	0.105 Amps (max.) at 24 V dc
Communications	DH-485
Certification	U.L. listed/CSA Approved

**Reference pages 32-36 for the HHT programming instruction set.**

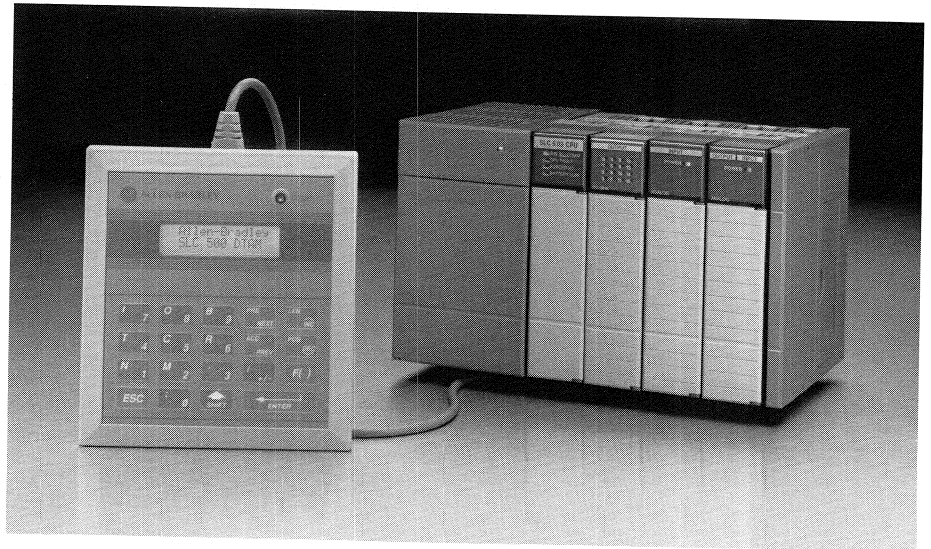

## Operator Interface

Allen-Bradley recognizes the need for efficient interface products. The Data Table Access Module aids in accessing information and monitoring an SLC 500 control system at the plant floor level.

### 1747-DTAM Data Table Access Module

The Data Table Access Module (DTAM) is a plant floor device that allows you to access data file information, change operating modes, monitor and clear processor faults, and transfer memory from EEPROM on any SLC 500, 5/01, or 5/02 family processor. Interactive messaging is also supported between the DTAM and the 5/02 processor.

Feature	Benefit
DH-485 Network Compatible	Communicates with up to 31 controllers, one at a time up to 4000 feet..
Data Monitor or Modify	Permits data values to be changed in the RUN mode.
Quick Recall Macros	Stores frequently used address locations, saving time and simplifying application set-up and change.
Auto-Attach Mode	Automatically initiates communication with the last processor after a power cycle, saving costly down time and reducing keystrokes.

**Data Table Access Module  
 (Continued)**

The following table describes a few of the features of the DTAM.

<b>Feature</b>	<b>Benefit</b>
On-Board Module Configuration	Provides non-volatile EEPROM memory for easy onsite module set up.
Multilingual Display	Selectable operator prompting in any of six languages.
Backlit LCD Display	Allows for easy viewing in all lighting conditions.
Responds to MSG Instructions	Allows interaction between ladder program and operator. The SLC 5/02 ladder program directs the dialog.

**DTAM Specifications**

The following table provides general specifications for the DTAM.

Display	2 line x 16 character super-twist nematic LCD with LED backlighting
Ambient Temperature Rating Operating Storage	0 to +55° C (32° to +131° F) -20° to +65° C (-4° to +149° F)
Humidity Rating	5-95% (without condensation)
Keyboard	9 keys with tactile feedback
Operating Power	0.104 Amps (max.) at 24 V dc
Communications	DH-485
Certification	U.L. listed/CSA certified. Meets NEMA Type 12 and 13 enclosure applications.

**Dimensional Specifications (Approximate)**

Front Panel:	Height	Width
	6.0 in. 152.4mm	5.5 in. 139.7mm
Back Case:	5.0 in. 127.0mm	4.0 in. 101.6mm

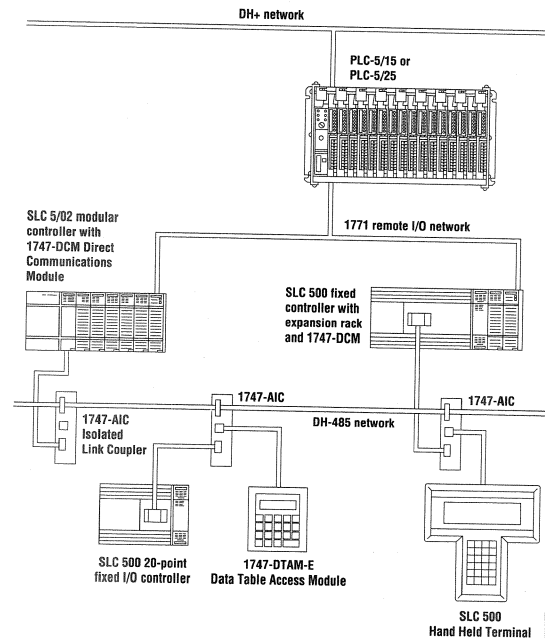

## Networking Options

SLC 500 programmable controllers communicate across an embedded DH-485 network for program support and monitoring. The following products provide networking options for the SLC 500 programmable controllers.

### 1747-DCM Direct Communications Module

The Direct Communications Module (DCM) links the Allen-Bradley PLC and SLC controller for distributed processing. The DCM acts as a remote I/O device to a PLC (supervisor) on the 1771 I/O link. Information is transferred from one processor to the other during each processor's I/O scan. The number of DCMs that a PLC can supervise depends on the number of racks the PLC scanner supports and the rack size of the DCM. Each SLC 500 fixed controller with a Catalog Number 1746-A2 expansion rack supports one DCM. The SLC 500 modular controller can support multiple DCMs.

The DCM can transfer the following number of words for each rack:

- 1/4 rack = 2 words (1 remote I/O word and 1 status word)
- 1/2 rack = 4 words (3 remote I/O words and 1 status word)
- 3/4 rack = 6 words (5 remote I/O words and 1 status word)
- full rack = 8 words (7 remote I/O words and 1 status word)

- Backplane Current Draw at 5 Volts dc is 0.36Amps.

### 1747-AIC Isolated Link Coupler for DH-485 Connection

The Isolated Link Coupler provides an electrically isolated network connection for an SLC 500 controller. One coupler is required at each DH-485 network drop. The coupler includes a 12 inch (304.8mm) cable for connection to the programmable controller. Note that a maximum of 32 devices can be connected to the network.

## System Overview

SLC 500 Family of Small  
Programmable Controllers

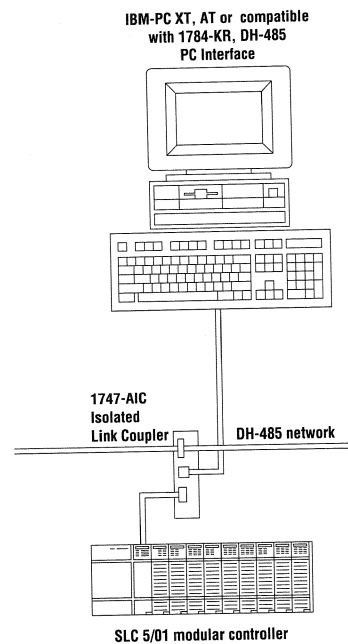

### 1784-KR Personal Computer Interface Card

The Personal Computer Interface Card provides an interface for IBM XT/AT and compatible computers to communicate over the Allen-Bradley DH-485 communications network. This includes communications to the Allen-Bradley line of SLC 500 programmable controllers.

Feature	Benefit
PC XT/AT Interface	Eliminates the need for the personal interface converter.
DH-485 Isolation	Eliminates the need for an isolated link coupler.
Reduces Personal Computer Overhead	Provides a faster update time for the user interface through the co-processor.

### Specifications

The following table provides general specifications for the 1784-KR Personal Computer Interface Card.

Power Requirements	+5 Volts dc, 1.8Amps
Outputs	RS-485 electrical/DH-485 protocol
Hardware Interrupt	IRQ2, IRQ3, IRQ4, IRQ5
Operating Temperature	0 to +60° C (32° to 140° F)
Humidity	5% to 95% non-condensing
Maximum Line Length	4000 ft. (1219.2 meters)

## 6001-F2E Standard Driver

The Standard Driver allows the 1784-KR card to be used on the DH-485 communications network for data acquisition applications. This allows you to write 'C' application programs that communicate directly over the DH-485 network to stations such as the SLC 500. Non-token passing slave stations such as the 2755-DM6 Bar Code Reader are also supported.

<b>Feature</b>	<b>Benefit</b>
Provides a Set of Linkable 'C' Function Calls	Establishes communications with devices on the DH-485 network.
Supports Microsoft 'C' v5.1 and Borland Turbo 'C' v2.0 Compilers	Eliminates the learning curve of new software packages.
Provides Application Libraries	Aids in data table read or write diagnostic commands.

## **Service and Support**

As the people who design, engineer and manufacture your Industrial Automation Control equipment, Allen-Bradley has a vested interest in your complete satisfaction with our products and services.

Allen-Bradley offers support services worldwide, with 78 Sales and Support offices and 494 Authorized Distributor locations throughout the United States and Allen-Bradley representatives in every major country in the world.

Contact your local representative for:

- Sales and Order Support
- Product Technical Training
- Software Technical Support
- Warranty Support
- Start-Up and On-Site Support
- Support Service Agreements

## Reference Section

The following section describes:

- How to configure an SLC 500 rack style system
- How to determine 1746 I/O compatibility
- Available programming instructions used with the 1747-PA2E Advanced Programming Software and the 1746-PT1 Hand-Held Terminal
- Analog Wiring Input/Output diagrams
- Dimensions for fixed and modular SLC 500 controllers

## SLC 500 Rack Configuration Instructions

This worksheet is intended to help you configure a modular style system. If a fixed I/O controller is more appropriate for your application, refer to page 4 of this System Overview. Each worksheet is meant to configure one rack of I/O. If multiple racks are necessary for your application, additional racks should be configured using another worksheet.

- 1. Estimate the total amount of memory this system requires**
  - a. Add up the number of discrete I/O points and place it in (a).
  - b. Add up the number of analog I/O points and place it in (b).
  - c. Add up the number of specialty I/O modules and place it in (c).
  - d. Multiply a, b, and c by the number indicated.
  - e. Total those numbers to give you a memory estimate.
  
- 2. Select a processor**
  - a. If memory requirements are less than 1K, choose a 5/01 CPU (1747-L511).
  - b. If memory requirements are greater than 1K, choose between 5/01 and 5/02. If your I/O requirements exceed 256, you must configure a 5/02 CPU (1747-L524).
  - c. Place your choice into slot 0 of rack 1 on the worksheet.
  
- 3. Select the I/O**
  - a. If multiple rack system, make copies for each rack.
  - b. Write in the rack number.
  - c. Write in the appropriate slot numbers.
  - d. Refer to pages 11 and 12 of the SLC 500 System Overview for discrete I/O selection.
  - e. Refer to pages 13 thru 15 for specialty and analog I/O selection.
  - f. Using the worksheet, list each I/O module in the slot you desire.
  - g. List the power consumption of each module in the designated columns. Be sure to account for future expansion.
  - h. When the rack is complete, add up each power consumption column.
  
- 4. Select the correct Power Supply**
  - a. Compare the Power Consumption totals with each power supply.
  - b. Choose the smallest power supply that provides sufficient power. Note that the current shown is rated at 55° C.
  
- 5. Select the Rack**
  - a. Add up the number of slots used.
  - b. Select the smallest rack which can hold your I/O. Be sure to account for future expansion.
  
- 6. Select the Miscellaneous Devices**

To complete your system, include devices such as:  
Cables  
Communication Interfaces  
Operator Interface Devices  
Memory Modules



## Determining Module Compatibility

When your application calls for adding 1746 I/O modules to an SLC 500 fixed I/O controller, some combinations of modules are not supported by the power supply. The following chart provides a quick reference in determining what combination of modules are compatible.

### Directions

Find the column marked 'Start Here'. Follow that column down until you find one of the modules you intend to add. Next, using the top row, find the next module you intend to add. Follow that column down to the box which intersects with the row of the first module.

A dot indicates that the combination is compatible. If the box is blank, the combination will not be supported by the hardware.

### Example

1. IB16 & OA16 = Valid Combination
2. OW8 and NIO4I = Invalid Combination

### Fixed Controller Expansion Rack Compatibility Chart

IA4	IA8	IA16	IM4	IM8	IM16	OA8	OA16	IB8	IB16	IV8	IV16	IG16	OV8	OV16	OB8	OG16	OW4	OW8	OW16	IO4	IO8	IO12	NI4	NIO4I	NIO4V	DCM	IMC	Start Here
•	•	•	•	•	•	•	•	•	•	•	•	•	•	•	•	•	•	•	•	•	•	•	•	•	•	•	•	IA4
	•	•	•	•	•	•	•	•	•	•	•	•	•	•	•	•	•	•	•	•	•	•	•	•	•	•	•	IA8
		•	•	•	•	•	•	•	•	•	•	•	•	•	•	•	•	•	•	•	•	•	•	•	•	•	•	IA16
			•	•	•	•	•	•	•	•	•	•	•	•	•	•	•	•	•	•	•	•	•	•	•	•	•	IM4
				•	•	•	•	•	•	•	•	•	•	•	•	•	•	•	•	•	•	•	•	•	•	•	•	IM8
					•	•	•	•	•	•	•	•	•	•	•	•	•	•	•	•	•	•	•	•	•	•	•	IM16
						•	•	•	•	•	•	•	•	•	•	•	•	•	•	•	•	•	•	•	•	•	•	OA8
							•	•	•	•	•	•	•	•	•	•	•	•	•	•	•	•	•	•	•	•	•	OA16
								•	•	•	•	•	•	•	•	•	•	•	•	•	•	•	•	•	•	•	•	IB8
									•	•	•	•	•	•	•	•	•	•	•	•	•	•	•	•	•	•	•	IB16
										•	•	•	•	•	•	•	•	•	•	•	•	•	•	•	•	•	•	IV8
											•	•	•	•	•	•	•	•	•	•	•	•	•	•	•	•	•	IV16
												•	•	•	•	•	•	•	•	•	•	•	•	•	•	•	•	IG16
													•	•	•	•	•	•	•	•	•	•	•	•	•	•	•	OV8
														•	•	•	•	•	•	•	•	•	•	•	•	•	•	OV16
															•	•	•	•	•	•	•	•	•	•	•	•	•	OB8
																•	•	•	•	•	•	•	•	•	•	•	•	OG16
																	•	•	•	•	•	•	•	•	•	•	•	OW4
																		•	•	•	•	•	•	•	•	•	•	OW8
																			•	•	•	•	•	•	•	•	•	OW16
																				•	•	•	•	•	•	•	•	IO4
																					•	•	•	•	•	•	•	IO8
																						•	•	•	•	•	•	IO12
																							•	•	•	•	•	NI4
																								•	•	•	•	NIO4I
																									•	•	•	NIO4V
																										•	•	DCM
																										•	•	IMC

• = Valid combination  
 Blank = Invalid combination

## Programming Instructions

Use the following programming instructions with the 1747-PA2E Advanced Programming Software (APS) or the 1747-PT1 Hand-Held Terminal.

### Input/Output Instructions

Name & Mnemonic Symbol	Symbol	Function
Examine If Closed	XIC	-] [-
Examine if Open	XIO	-]/[-
One Shot Rising	OSR	-]OSR[-
Output Energize	OTE	-( )-
Output Latch	OTL	-(OTL)-
Output Unlatch	OTU	-(OTU)-
•• Nested Branching		Creates conditional multiple parallel paths in a rung.

### Timer/Counter Instructions

Timer On-Delay	TON	-[TON]-	Allows timing at a .01 second rate for 5/01 or 1 second for the 5/02.
Timer Off-Delay	TOF	-[TOF]-	
Retentive On-Delay Timer	RTO	-[RTO]-	On-delay timer that retains its accumulative time.
Count Up	CTU	-[CTU]-	Counts events based on programmed number of counts. Range: -32,768 to +32,767
Count Down	CTD	-[CTD]-	
High Speed Counter	HSC	-[HSC]-	Counts high speed pulses from high speed input from only a fixed style controller. Maximum Pulse Rate: 8 kHz Range: 0 to +32,767

### Immediate Input/Output Instructions

Immediate Input With Mask	IIM	-[IIM]-	Interrupts program scan to read or write a word of external I/O.
Immediate Output	IOM	-[IOM]-	
With Mask			

•• Only applies to the 5/02 processor

## Programming Instructions (Continued)

### Comparison Instructions

Name & Mnemonic Symbol	Symbol	Function
Equal EQU	-[EQU]-	<b>Instruction is true when:</b> Source 1 = Source 2
Not Equal NEQ	-[NEQ]-	Source 1 <> Source 2
Less Than LES	-[LES]-	Source 1 < Source 2
Greater Than GRT	-[GRT]-	Source 1 > Source 2
Less Than or Equal LEQ	-[LEQ]-	Source 1 ≤ Source 2
Greater Than or Equal GEQ	-[GEQ]-	Source 1 ≥ Source 2
Masked Comparison for Equal MEQ	-[MEQ]-	Data at the source address through a mask is equal to data at another address.
•• Limit Test LIM	-[LIM]-	Source 1 < Test value < Source 2

### File Instructions

Copy File COP	-[COP]-	<b>When the rung is true:</b> Copies file starting with source address to destination file starting with destination address for specified length.
File Fill FLL	-[FLL]-	Fills file starting with destination address with contents of source word or constant value.

### Move And Logical Instructions

Move MOV	-[MOV]-	<b>When the rung is true:</b> Move Source to the destination.
Masked Move MVM	-[MVM]-	Move Source 1 through mask. Store result in destination.
And AND	-[AND]-	Logical And Source 1 and Source 2. Store result in destination.
Or OR	-[OR]-	Logical Or Source 1 and Source 2. Store result in destination.
Exclusive Or XOR	-[XOR]-	Exclusive Or Source 1 and Source 2. Store result in destination.
Not. NOT	-[NOT]-	Logical Not Source. Store result in destination.

•• Only applies to the 5/02 processor

## Programming Instructions (Continued)

### I/O Message Instructions

Name & Mnemonic Symbol	Symbol	Function
•• Service Communications	SVC	-(SVC)- <b>When rung is true:</b> Interrupt program scan to process communication requests.
•• Message	MSG	-(MSG)- Provides the ability to read or write messages to other DH-485 nodes.
•• I/O Interrupt Enable	IIE	-(IIE)- Enables the I/O interrupt subroutine.
•• I/O Interrupt Disable	IID	-(IID)- Disables the I/O interrupt subroutine.
•• Reset Pending I/O Interrupt	RPI	-(RPI)- Resets pending I/O interrupt.
•• Refresh	REF	-(REF)- Interrupt program scan to scan I/O and process communications request.

### Math Instructions

Add	ADD	-[ADD]-	<b>When the rung is true:</b> Add source 1 to Source 2, put in destination.
Subtract	SUB	-[SUB]-	Subtract Source 1 from Source 2, put in Destination.
Multiply	MUL	-[MUL]-	Multiply Source 1 and Source 2, put in Math Register and Destination.
Divide	DIV	-[DIV]-	Divide Source 1 by Source 2, put in Math Register and Destination.
Double Divide	DDV	-[DDV]-	Divide the math register by Source 2, put in destination.
Clear	CLR	-[CLR]-	Set the contents of the destination to zero.
Negate	NEG	-[NEG]-	Change the sign of the destination.
Convert to BCD	TOD	-[TOD]-	Converts source value to BCD value and stores result in either Math Register or the Destination.
Convert from BCD	FRD	-[FRD]-	Converts Math Register or Source 1 BCD value to integer value and stores result in Destination.
Decode	DCD	-[DCD]-	Decodes integer value 0 to 16, to corresponding bit in sixteen bit word.
•• Square Root	SQR	-(SQR)-	Places the square root of the Source into the Destination.
•• Scale Data	SCL	-(SCL)-	Allows scaling to engineering units.

•• Only applies to the 5/02 processor

## Programming Instructions (Continued)

### Program Control Instructions

Name & Mnemonic Symbol	Symbol	Function
Label LBL	-[LBL]-	Target for jump instruction.
Jump to Subroutine JSR	-[JSR]-	Shifts program execution to beginning of sub-routine file.
Return from Subroutine RET	-[RET]-	Returns program execution to the previous execution point.
Master Control Reset MCR	-(MCR)-	Used as a pair to enable or inhibit a group of ladder rungs.
Temporary End TND	-(TND)-	Stops the program scan, updates I/O, resumes scan at Rung 1 of the main program.
Suspend SUS	-[SUS]-	Stops program scan, disables outputs and identifies exact event.
Subroutine Label SBR	-[SBR]-	Target for jump to subroutine instruction.
Jump JMP	-(JMP)-	Shifts program execution to corresponding label.
•• I/O Interrupt INT	-[INT]-	Target for user interrupt.
•• Selectable Timed Interrupt Enable STE	-(STE)-	Enables selectable timed interrupt function.
•• Selectable Timed Interrupt Start Immediately STS	-(STS)-	Restarts selectable timed interrupt timer.
•• Selectable Timed Interrupt Disable STD	-(STD)-	Disables selectable timed interrupt function.

•• Only applies to the 5/02 processor

## Programming Instructions (Continued)

### Bit Shift And Sequencer Instructions

Name & Mnemonic Symbol	Symbol	Function
Bit Shift Left BSL	–[BSL]–	<b>When the rung goes False to True:</b> Shifts data into file one bit at a time and unloads one bit at a time.
Bit Shift Right BSR	–[BSR]–	Shifts data into file one bit at a time and unloads one bit at a time.
Sequencer Output SQO	–[SQO]–	<b>When the rung is true:</b> Transfers data from a file to an address or file through a mask for sequential control.
Sequencer Compare SQC	–[SQC]–	Diagnostic instruction – compares a word or file to another word or file through a mask for equality.
●● Sequencer Load SQL	–(SQL)–	Loads data from an address into a sequencer file.
●● Load, First In First Out FFL	–(FFL)–	<b>When the rung goes False to True:</b> Push FIFO stack.
●● Unload, First In First Out FFU	–(FFU)–	Pop FIFO stack.
●● Load, Last In First Out LFL	–(LFL)–	Push LIFO stack.
●● Unload, Last In First Out LFU	–(LFU)–	Pop LIFO stack.

### Special Instructions

●● Proportional Integral Derivative PID	–(PID)–	Controls PID loop.
---	---------	--------------------

●● Only applies to the 5/02 processor

## Wiring Input Modules

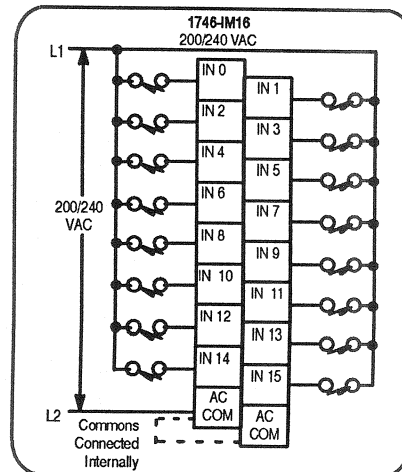
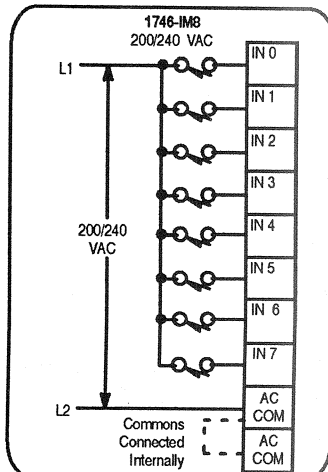
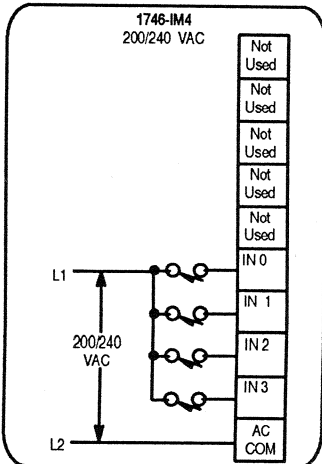
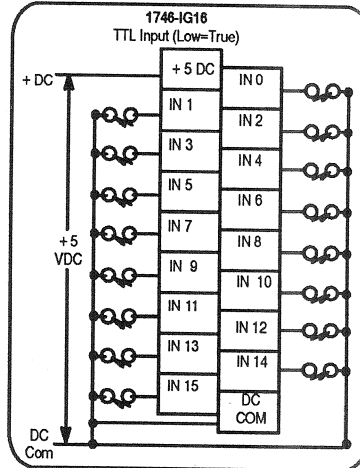
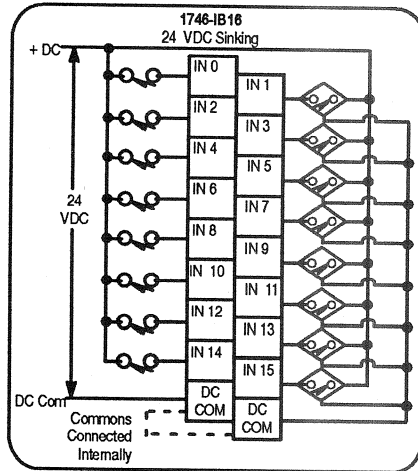
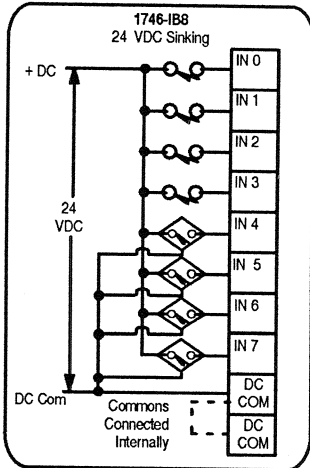
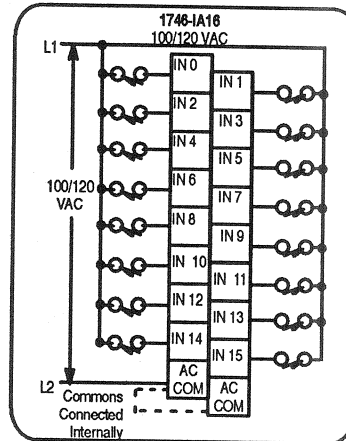
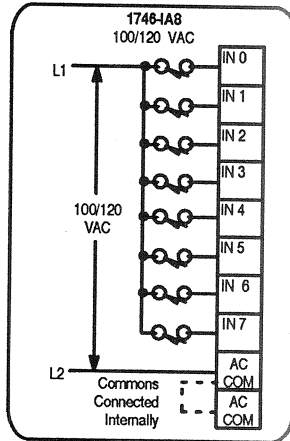
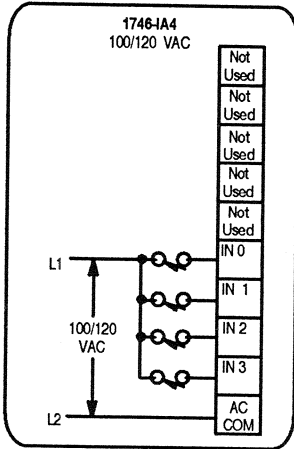

### Wiring Input Modules

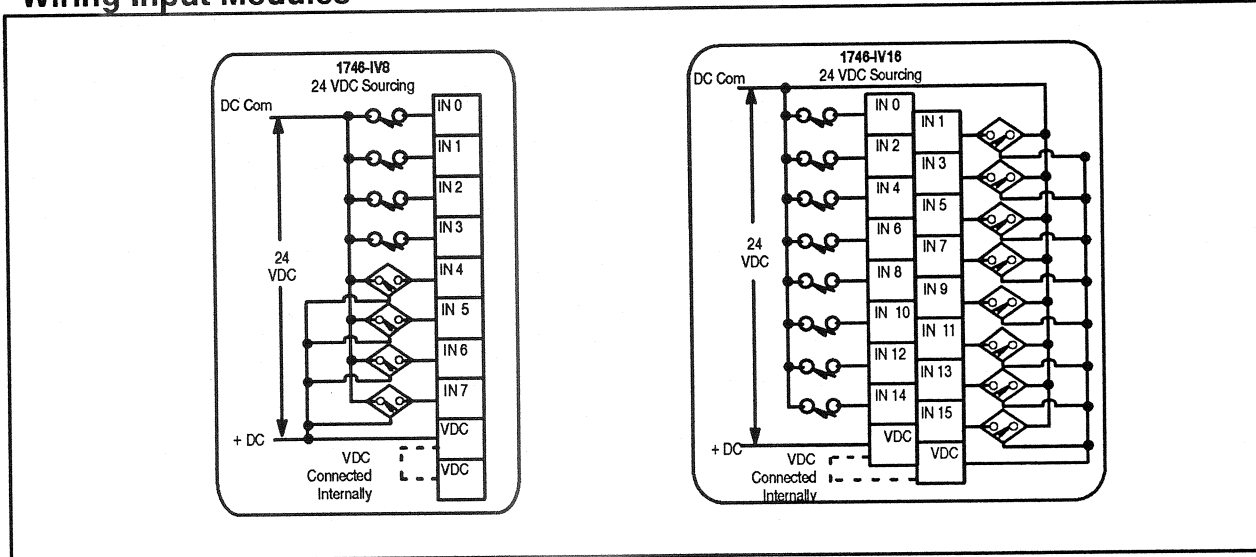

### Wiring Output Modules

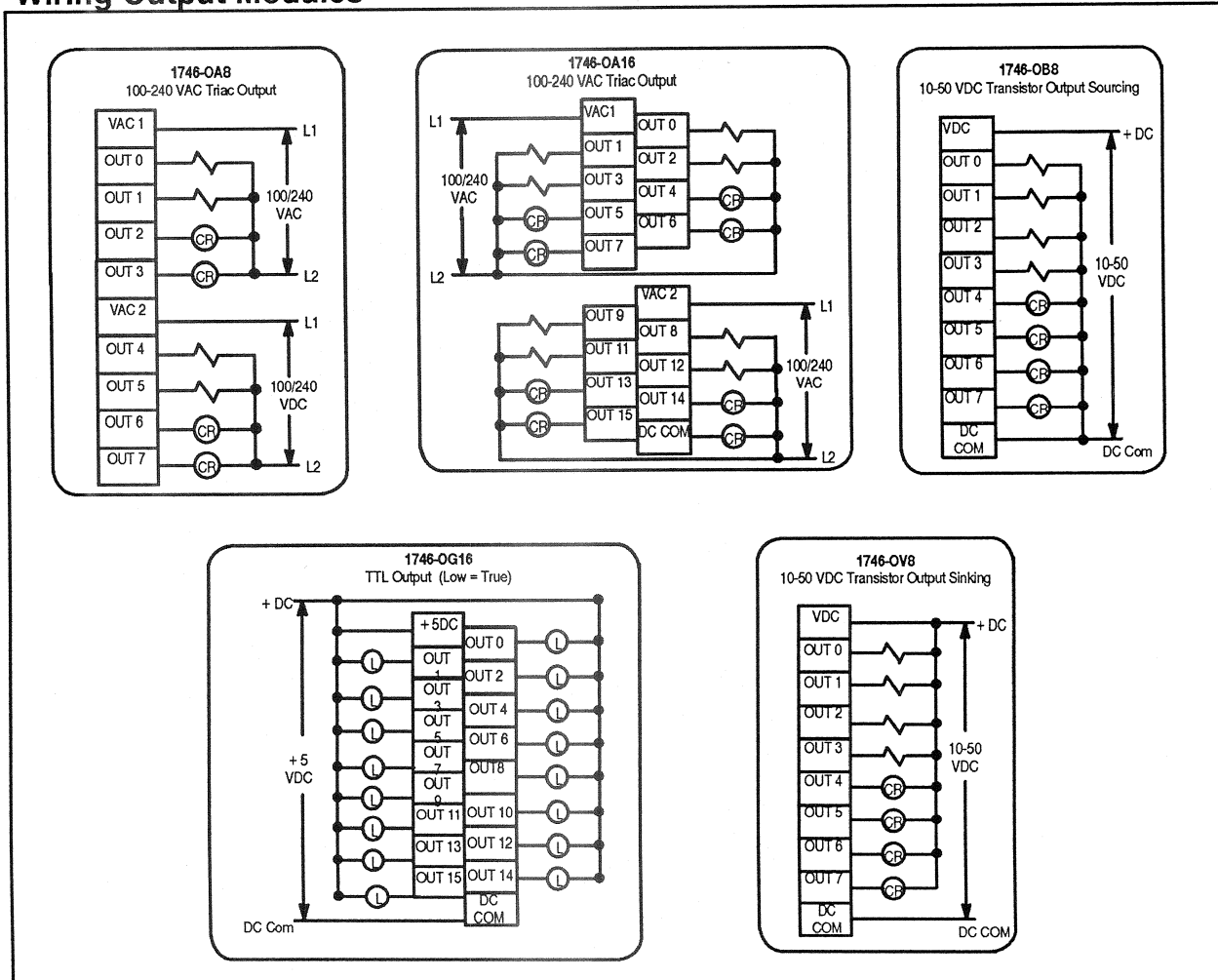

### Wiring Output Modules

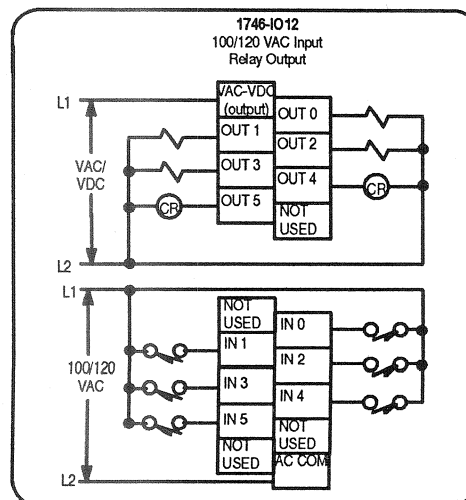
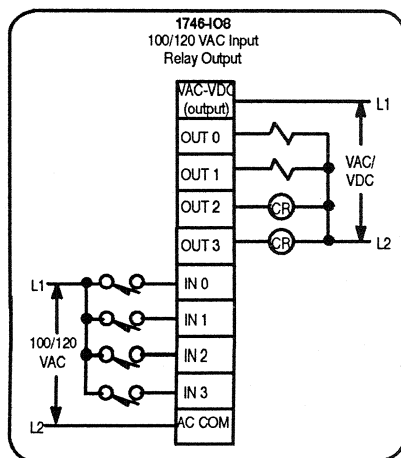
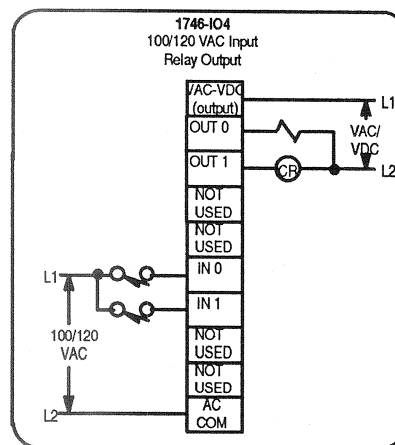
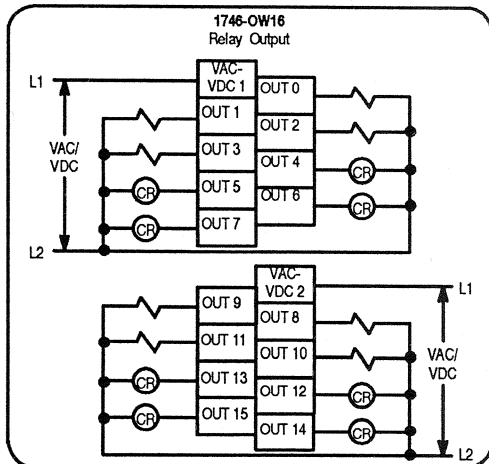
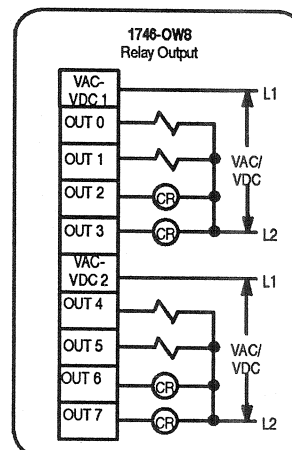
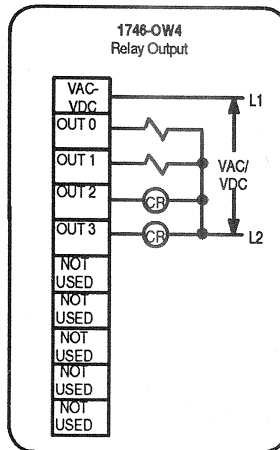
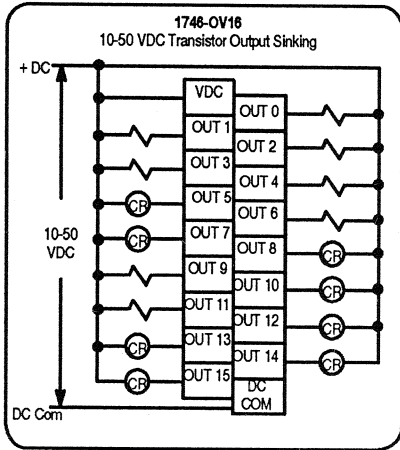

## Approximate Dimensions

### 20 I/O Fixed Hardware Style

**NOTE:** All dimensions are in inches. (Dimensions in parentheses are in millimeters.)

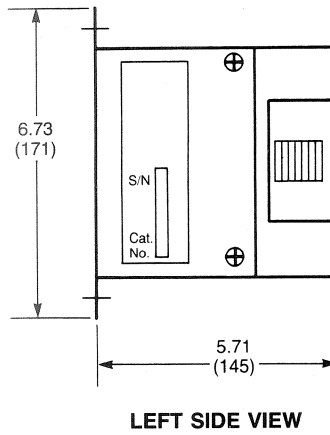
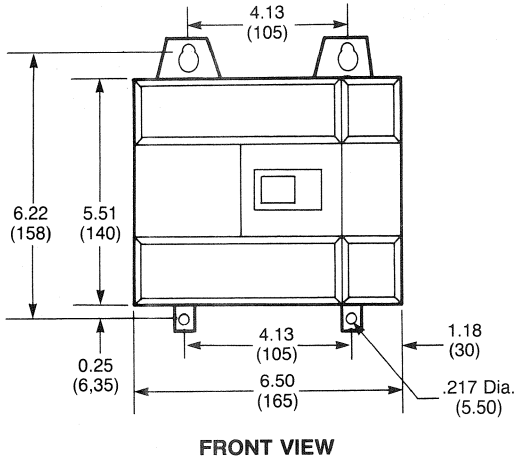

### Two Slot Expansion Rack

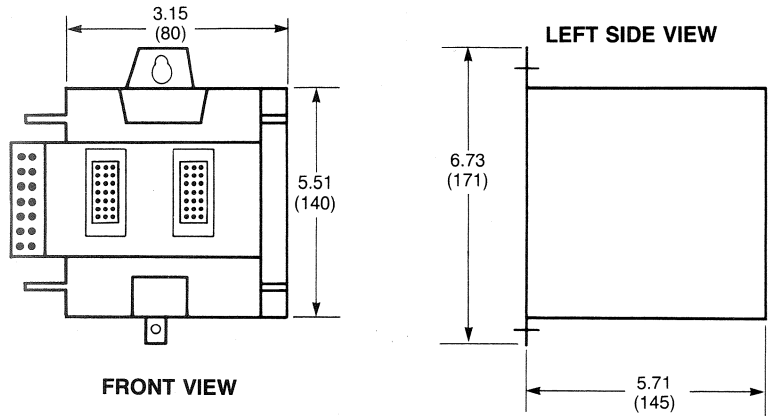

### 30 & 40 I/O Fixed Style Hardware

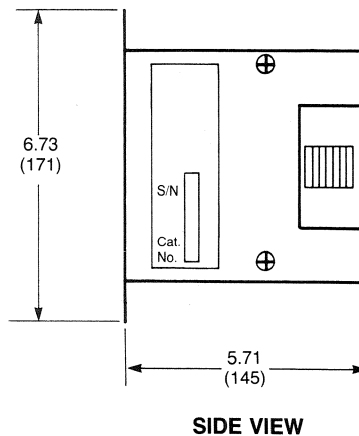
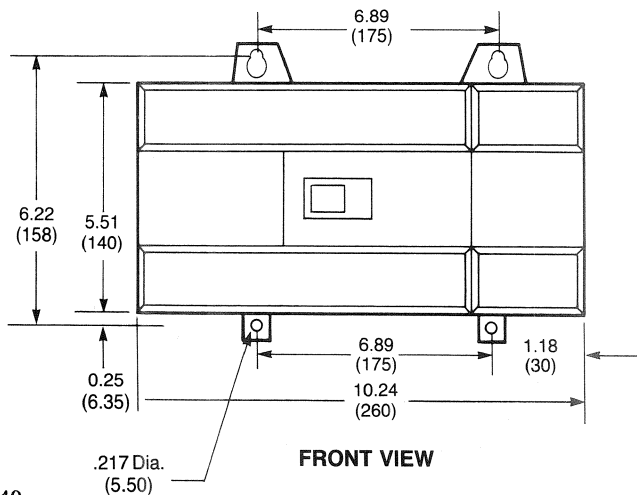

**4 Slot Rack**

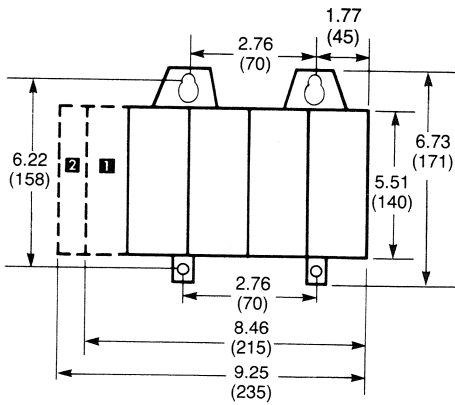

**10 Slot Rack**

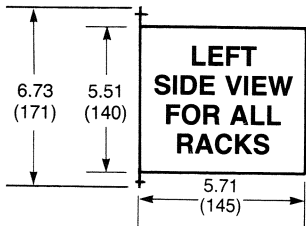
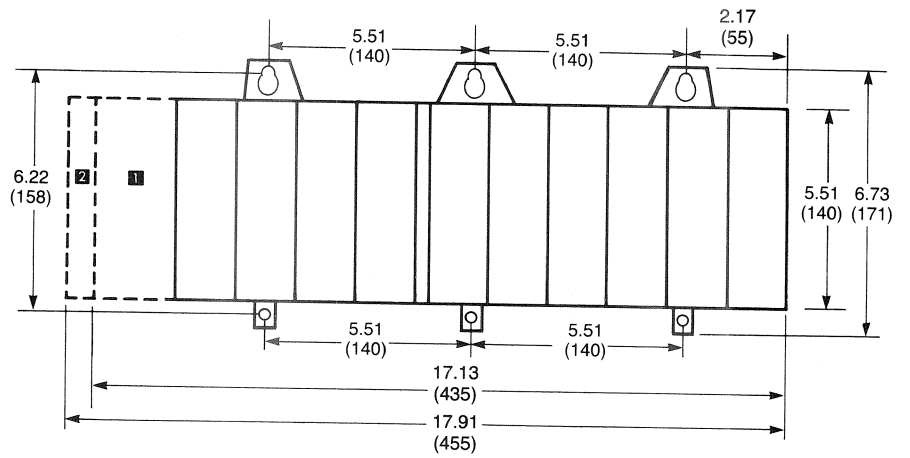

**7 Slot Rack**

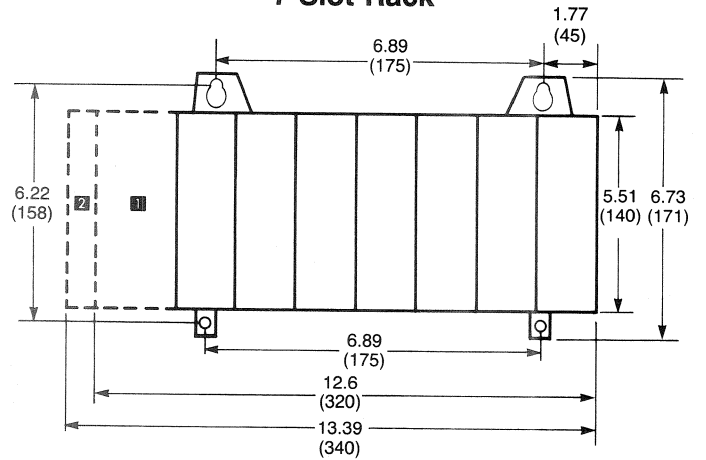

**13 Slot Rack**

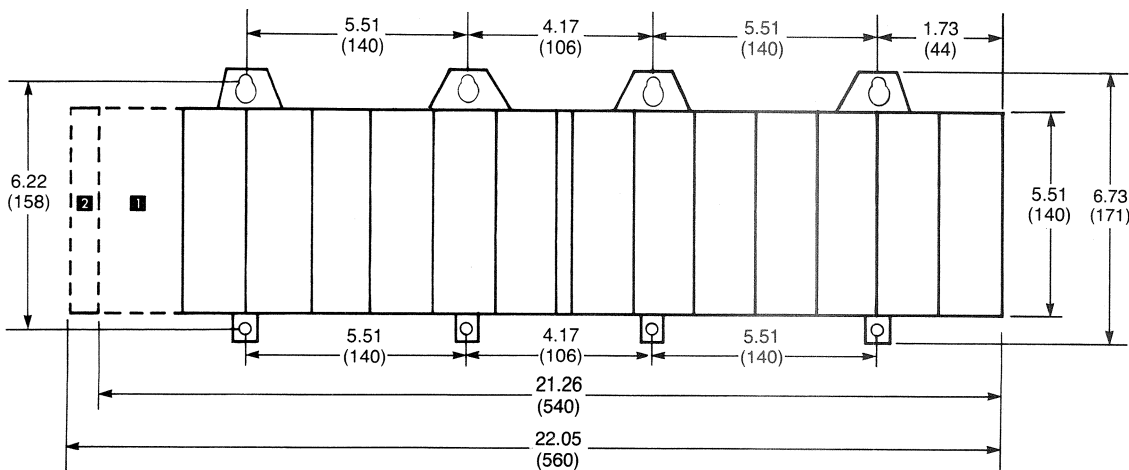

■ Dimension for Power Supply Catalog No. 1746-P1.  
 ■ Dimension for Power Supplies Catalog Nos. 1746-P2 & 1746-P3.

## **Notes**

## Notes

## Notes

© 1991 Allen-Bradley Company



**ALLEN-BRADLEY**  
A ROCKWELL INTERNATIONAL COMPANY

A subsidiary of Rockwell International, one of the world's largest technology companies, Allen-Bradley meets today's automation challenges with over 85 years of practical plant floor experience. More than 13,000 employees throughout the world design, manufacture and apply a wide range of control and automation products and supporting services to help our customers continuously improve quality, productivity and time to market. These products and services not only control individual machines, but also integrate the manufacturing process while providing access to vital plant floor data that can be used to support decision-making throughout the enterprise.

With offices in major cities worldwide.

**WORLD HEADQUARTERS**

Allen-Bradley  
1201 South Second Street  
Milwaukee, WI 53204 USA  
Tel: (414)382-2000  
Telex: 43 11 016  
FAX: (414)382-4444

**EUROPE/MIDDLE EAST/  
AFRICA HEADQUARTERS**

Allen-Bradley Europe B.V.  
Amsterdamseweg 15  
1422 AC Uithoorn  
The Netherlands  
Tel: (31)2975/43500  
Telex: (844) 18042  
FAX: (31)2975/60222

**ASIA/PACIFIC HEADQUARTERS**

Allen-Bradley (Hong Kong) Limited  
Room 1006, Block B, Sea View Estate  
2-8 Watson Road  
Hong Kong  
Tel: (852)887-4788  
Telex: (780) 64347  
FAX: (852)510-9436

**CANADA HEADQUARTERS**

Allen-Bradley Canada Limited  
135 Dundas Street  
Cambridge, Ontario N1R 5X1  
Canada  
Tel: (519)623-1810  
FAX: (519)623-8930

**LATIN AMERICA  
HEADQUARTERS**

Allen-Bradley  
1201 South Second Street  
Milwaukee, WI 53204 USA  
Tel: (414)382-2000  
Telex: 43 11 016  
FAX: (414)382-2400