



**KEY TO WORLD-CLASS  
MANUFACTURING**

# **THE PYRAMID INTEGRATOR™**

▶ **FROM ALLEN-BRADLEY  
AN INTERNATIONAL LEADER  
IN INDUSTRIAL AUTOMATION**

**PYRAMID**  
Integrator

▲  
**INTEGRATING  
CONTROL AND  
INFORMATION.  
THE COMPETITIVE  
ADVANTAGE.**

**WORKING HARDER BY  
WORKING SMARTER**

To succeed in today's highly competitive, global marketplace, companies are looking to:

- Improve product quality.
- Increase productivity.
- Reduce product life cycle investments.
- Have timely, plant-wide access to information.

To achieve these goals, Allen-Bradley has evolved the Productivity Pyramid concept, a framework for manufacturing success.

**BLUEPRINT FOR SUCCESS**

The Productivity Pyramid is a blueprint for achieving the step-by-step implementation of computer integrated manufacturing (CIM). This blueprint divides a manufacturing operation into five separate and distinct levels of responsibility. Each level depends on the efficient, accurate flow of information both horizontally and vertically.

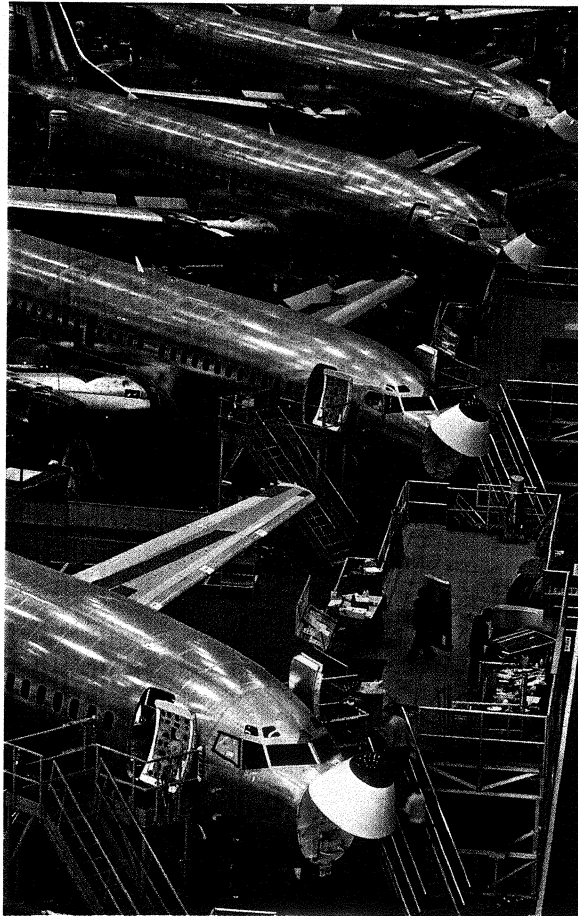

*Computer Integrated Manufacturing (CIM) is the necessary next step for achieving world-class quality.*

▲  
**PRODUCTIVITY  
PYRAMID**

**MACHINERY/PROCESS LEVEL.** Where products are made and upper level commands are carried out; and where plant floor data is generated for evaluation.

**STATION LEVEL.** Where higher level commands are received and implemented by controlling individual production machines. By continuously monitoring Machinery/Process Level inputs and changing outputs accordingly, Station Level devices precisely and automatically control the production process. Plant floor information is processed and reported to the next level.

**CELL LEVEL.** Where data processing and plant floor control meet and merge. By monitoring and coordi-

nating Station Level devices, integrated Cell Level systems can make production adjustments that introduce new scales of productivity.

**CENTER LEVEL.** Where production is scheduled through local area communication networks and management is provided with the necessary information to keep work flowing smoothly.

**PLANT LEVEL.** Where overall strategic planning and execution take place using mainframe computers and proven broadband communication networks.

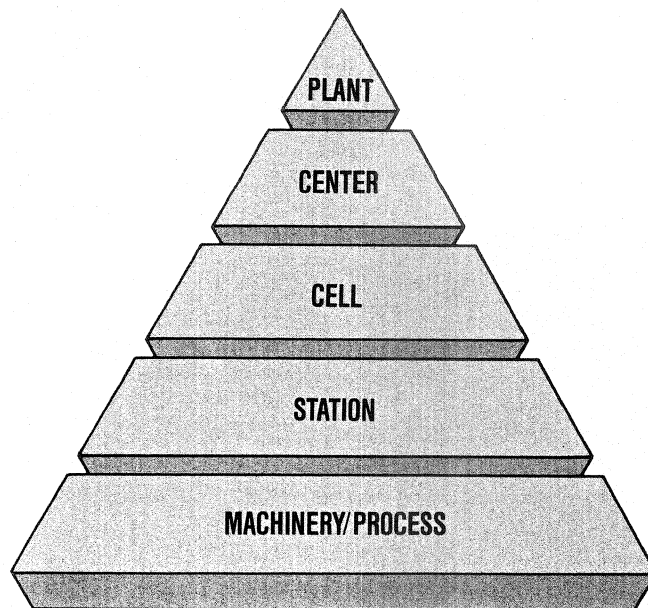

▲  
**INTRODUCING  
THE PYRAMID  
INTEGRATOR**

**TURNING THE CONCEPT INTO REALITY**

In today's manufacturing environment, joining the worlds of information and control is achieved by *interfacing* diverse systems. But this is a difficult and expensive solution because it requires software, hardware and support from different vendors. The key to true CIM is *integration*, not interfacing. To accomplish this, Allen-Bradley realized that providing a first-class solution to our customers involved integrating control and partnering with other CIM leaders.

Digital Equipment Corporation, a recognized leader in networked manufacturing information management systems, is our first partner. In this alliance, Allen-Bradley provided real-time control and plant-floor communications. Digital provided information processing and plant integrator communications.

The Pyramid Integrator is this first-class solution. This device unifies Machinery/Process and Station Levels, and links them directly to Cell, Center and Plant

Levels. For the first time both horizontal and vertical integration of the manufacturing process has become possible.

What does this breakthrough mean for today's manufacturers?

□ *The Pyramid Integrator provides an integrated systems approach for managing plants.*

□ *For the first time, control and information processors work together along a common backplane.*

□ *Its modular design is uniquely packaged for an industrial environment.*

□ *VMS users can now communicate directly to the plant floor via DECnet.*

**AN ARCHITECTURE FOR  
TODAY AND TOMORROW**

The Pyramid Integrator has a flexible and expandable foundation. Its components have both integrated and stand-alone capabilities. With an architecture that's designed for today's needs. And expandable to meet the growing integration of control and information technologies.

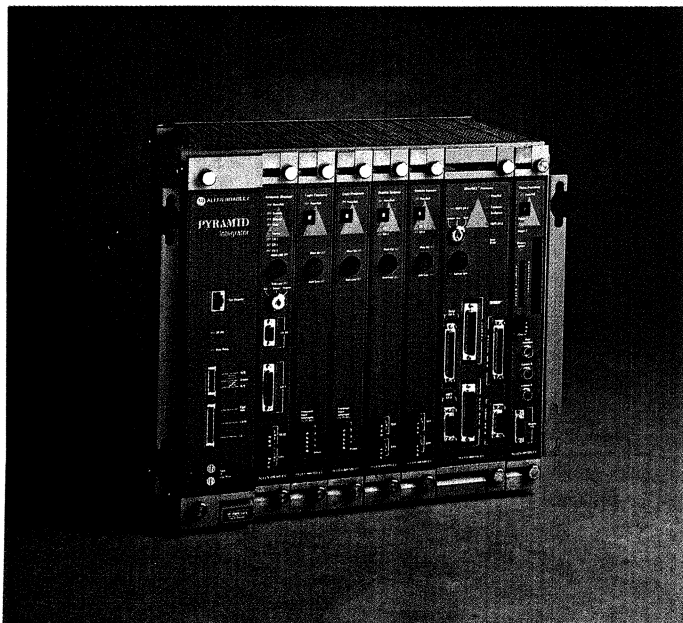

*The Pyramid Integrator brings together control and information processing capabilities in a single chassis. Shown here is the Pyramid Integrator 8-slot chassis holding the following modules: Resource Manager, 2 Logic Processors, 2 Remote Scanners, MicroVAX™ Information Processor, and CVIM™ Vision Processor.*



## **PYRAMID INTEGRATOR COMPONENTS**

The basic Pyramid Integrator is a 4- or 8-slot chassis holding the three modules described below. Its expanded capabilities are outlined on the following pages with the addition of its other components.

### **4- OR 8-SLOT CHASSIS**

The Pyramid Integrator chassis has a 4- or 8-slot configuration with the following features:

- Common backplane for high-speed, parallel communications.
- Panel or 19" rack mount.

### **POWER SUPPLY**

The Power Supply provides power to all modules installed in the chassis and includes these features:

- Switch selectable for 110/220 input voltages.
- Interlock relay connector.
- Line voltage indicator.

### **RESOURCE MANAGER**

The Resource Manager is used by all modules in the chassis and provides bus arbitration on the backplane. It also features:

- Three communications channels.
- Two Data Highway and/or Data Highway Plus
- One RS232C/422
- 128K or 384K words of global memory for data table storage.
- System real-time clock.

### **REMOTE SCANNER**

The Remote Scanner connects to the Allen-Bradley Remote I/O communication network. This network has an installed base of more than 3,000,000 I/O modules and other Allen-Bradley devices such as drives, motion controls, programmable controllers and operator interface products.

This module features:

- Two Remote I/O channels.
- 1024 I/O points per scanner.
- Up to four scanners per system.
- Fast block transfer.
- I/O image table stored on board.

▲  
**THE PLC-5/250  
PROGRAMMABLE  
CONTROLLER**

**ADVANCED CONTROL  
LOGIC PROCESSOR**

The 5/250 Logic Processor is an advanced processor that increases information accessibility and accelerates its flow through the Pyramid Integrator by using:

- A custom Allen-Bradley ladder logic chip.
- A 68020 32-bit microprocessor.
- A high-speed program logic execution of less than 1 ms/K.
- Two memory capacities: 192KW and 348KW.
- Up to four directly connected DC inputs for time-critical responses.

When combined with the Resource Manager and Remote Scanner modules, the Logic Processor becomes a powerful programmable controller system, the PLC-5/250.

The PLC-5/250 is the newest addition to Allen-Bradley's PLC-5 family of programmable controllers. Its features include:

- An enhanced PLC-5 instruction set.
- Sequential function chart programming.
- Communications with 1771 I/O, Data Highway and Data Highway Plus.
- Advanced parallel processing.
- Up to four Logic Processors that do separate and distinct tasks while communicating with each other for multi-task coordination.

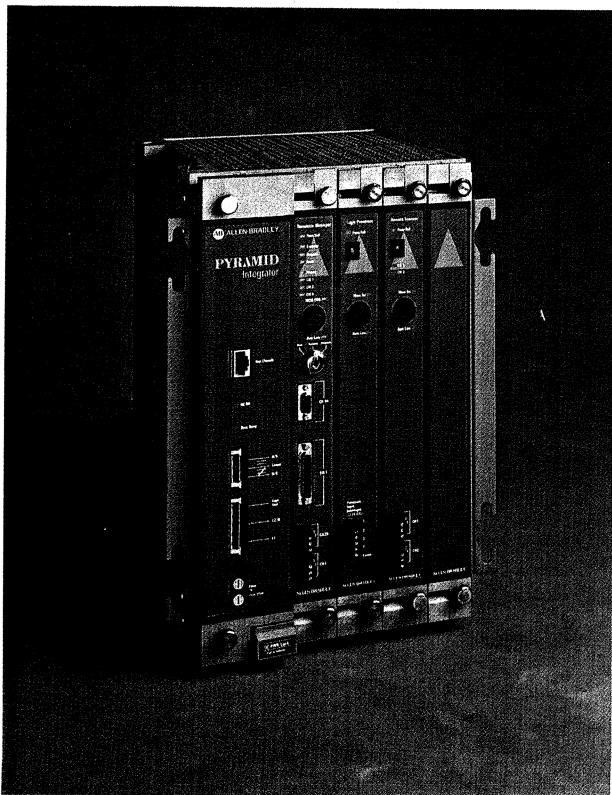

*The PLC-5/250 is an advanced programmable controller. It can accommodate multiple Logic Processors and Remote Scanners as applications require. Shown here are the modules mounted in the Pyramid Integrator chassis: Resource Manager, Logic Processor and Remote Scanner.*



## CONTROLLING THE FLOW OF INFORMATION

*The Pyramid Integrator helps manufacturers achieve new levels of efficiency.*

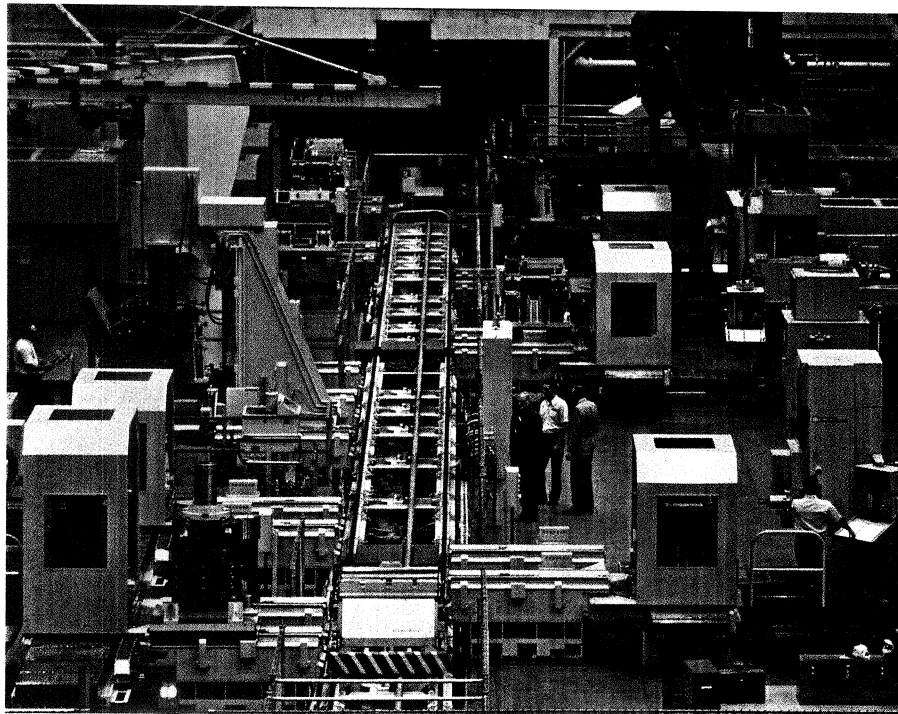

The PLC-5/250 programmable controller can supervise other controllers as well as control its own I/O. By controlling this important flow of information, the PLC-5/250 can help manufacturers realize increased cost performance and cost savings, as well as improved product quality.

### **IMPROVED COST PERFORMANCE FOR LARGE CONTROL APPLICATIONS**

The PLC-5/250 controller can improve critical cost performances by:

- Organizing and processing information provided by other controllers.
- Allowing other computers easy access to this information.
- Reducing computer response times.

### **LEVERAGED INVESTMENT IN PLC-5 PROGRAMMING AND MAINTENANCE TRAINING**

The PLC-5/250 controller is an extension of the PLC-5 family. This leverages current investments in programming and maintenance by:

- Shortening the operations learning curve.
- Reducing programming costs because of familiarity with existing systems.

### **INCREASED COST SAVINGS THROUGH PRODUCT COMPATIBILITY**

- Compatible with Allen-Bradley's 1771 I/O and Data Highway Plus.
- Gathers large amounts of information quickly.
- Transfers information easily to other areas of the plant.

### **INTEGRATES WITH PYRAMID VISION AND INFORMATION PROCESSORS**

While the PLC-5/250 programmable controller has stand-alone capabilities, it is even more powerful when integrated with the vision and information-processing functions of the CVIM and MicroVAX modules.

### **INCREASED ENGINEERING PRODUCTIVITY**

The PLC-5/250 programmable controller can increase engineering productivity by:

- Using 6200 Series software for online/offline programming and documentation. This software runs on the MicroVAX Information Processor as well as Allen-Bradley's T45 and T50 terminals.
- Following Sequential Function Charts (SFC) that help develop and organize ladder logic programs.

**CVIM™**  
**CONFIGURABLE VISION**  
**INPUT MODULE**

**IMPROVING QUALITY IN  
THE BLINK OF AN EYE**

The CVIM module provides a simple, easy-to-use set of vision tools for the Pyramid Integrator. It can be configured to meet basic inspection needs. And it can be easily reconfigured for future applications so that the vision system of today will be your vision system for tomorrow.

**GREATER ACCURACY THAN  
VIRTUALLY ANY OTHER PLANT FLOOR  
VISION SYSTEM**

The CVIM vision system offers these important process control benefits:

*More accurate measurement.* The CVIM module has built-in features to get optimal performance out of camera and lens set-ups.

*Assembly verification.* The CVIM module can quickly locate and verify that a piece has been properly assembled, even when its location varies from inspection to inspection.

*Print verification.* The CVIM module can be programmed to verify labels, lot numbers, expiration dates and other printed information that changes week-to-week, day-to-day or even hour-to-hour.

*Packaging verification.* The CVIM module can verify critical consumer packaging information such as proper sealing and fill levels.

*The Pyramid Integrator's advanced vision system provides accurate, easily-accessed information concerning measurements, assemblies, print and packaging verification.*

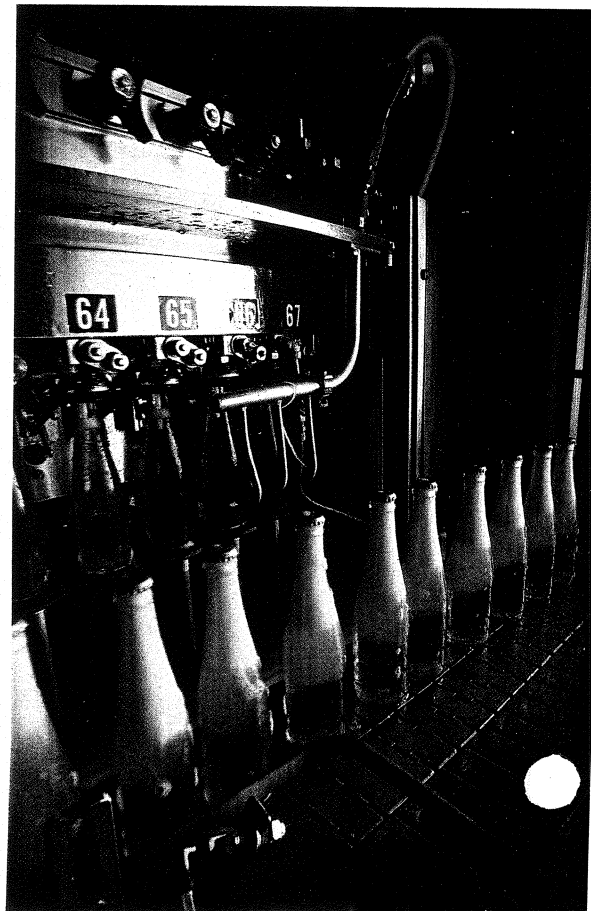

## ▲ INTEGRATING PROCESS CONTROL

## A PARTNERSHIP BETWEEN MACHINE VISION AND THE PYRAMID INTEGRATOR

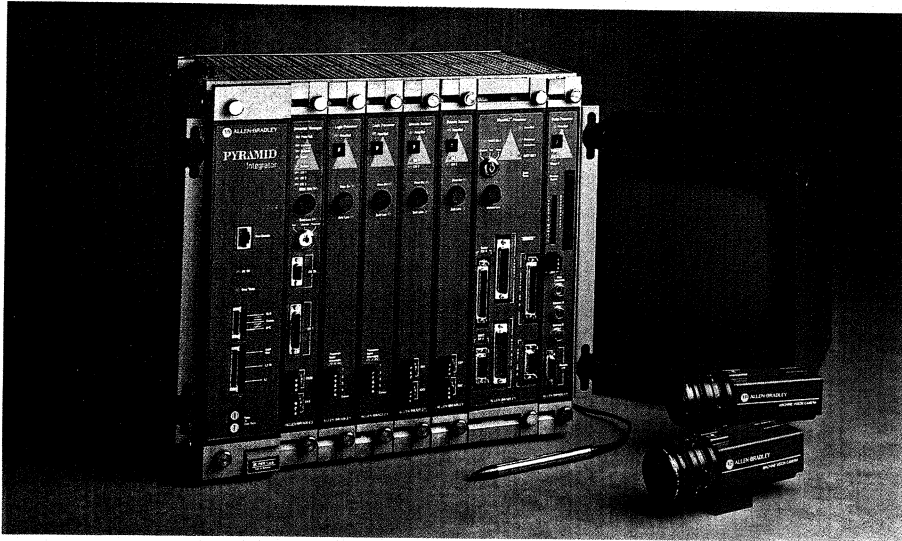

*The CVIM configurable vision input module is designed for sophisticated process control applications, yet is a highly adaptable and easy-to-use machine vision tool. Shown here is the CVIM module mounted in the Pyramid Integrator chassis.*

Sophisticated process control is only possible with a completely integrated system. Using the Pyramid Integrator's PLC-5/250 Controller and MicroVAX Information Processor, CVIM's inspection results can be monitored continually. Corrective action can then be directed back up the production stream. Or the Pyramid Integrator itself can reconfigure the CVIM module to adapt to a changing situation. Using CVIM's vision tools, here are some of the functions offered by this advanced vision system:

- Statistical process control.* Each inspection provides up to 205 points of result information.
- Real-time process control feedback.* Each vision tool has four user definable limits.
- High-speed inspection.* Parts moving past CVIM's solid state camera can be monitored at the rate of 1800 parts per minute.
- Reduced production waste.* Upstream controllers can use the data from the CVIM module to help prevent wasted production.

- Higher quality production and reduced product warranty costs.* The CVIM module's accuracy and fast response lets manufacturers narrow specification limits, resulting in consistently higher quality products, while minimizing the escape of defective products into the marketplace.

### EIGHT VISION TOOLS FOR SPECIFIC APPLICATIONS

The CVIM module has eight vision tools to use in meeting specific applications and configurations.

- Light meter.* To compensate for lighting variations.
- Measurement windows.* To inspect different shaped areas.
- Measurement gauges.* To inspect along a line.
- Shift adjustments.* To help locate objects in the X-Y direction.
- Rotation adjustments.* To help locate objects which have rotated plus/minus 15 degrees off center.
- Trial run.* To gather data and adjust tolerances.
- Noise filtering.* To compensate for image noise.
- Lens mapping.* For subpixel accuracy.

# MICROVAX™ INFORMATION PROCESSOR

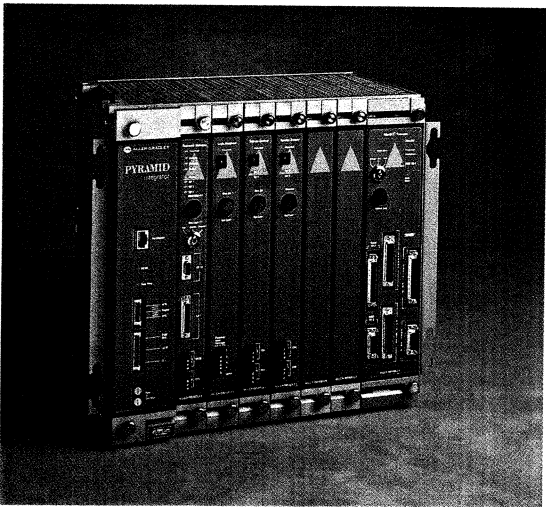

*This photograph shows the MicroVAX Information Processor in the Pyramid Integrator 8-slot chassis. This configuration shows the Resource Manager, a Logic Processor, 2 Remote I/O Scanners, and the MicroVAX Processor.*

## INTEGRATED INFORMATION PROCESSING

Through the MicroVAX Information Processor, Digital's VAX/VMS computing power and DECnet networking capability have been integrated into the Allen-Bradley world of industrial controls.

The MicroVAX Information Processor provides a cost-effective, easily implemented gateway from real-time controls to MIS. This creates a seamless integration between plant floor systems and information management.

This is a unique product, a true Digital MicroVAX computer exclusively manufactured, sold and supported by Allen-Bradley. The MicroVAX Information Processor shortens data acquisition times through its tight coupling with other Pyramid Integrator modules via the high-speed backplane.

Pyramid Integrator users will have access to a broad portfolio of VMS application software, from both Digital and third-party vendors.

Among the many features associated with this information processor are:

- An industrially-hardened 32-bit computer.
- VMS operating system.
- Eight megabytes of RAM.
- Local interface for an industrially-hardened disk.
- DECnet communications port.
- Four RS232 ports.

## LOCAL AREA VAXCLUSTER™ NETWORKING

When part of a VAXcluster network, the MicroVAX Information Processor can operate in a diskless mode, which permits extensive and flexible data storage and resource sharing via DECnet.

## DATA TABLE LIBRARY

The Data Table Library is the software link between the Pyramid Integrator and a VMS program. This library provides read and write access to all data tables within Pyramid Integrator modules by converting PLC data to a VMS format. It is designed to work with both "C" and Fortran languages.

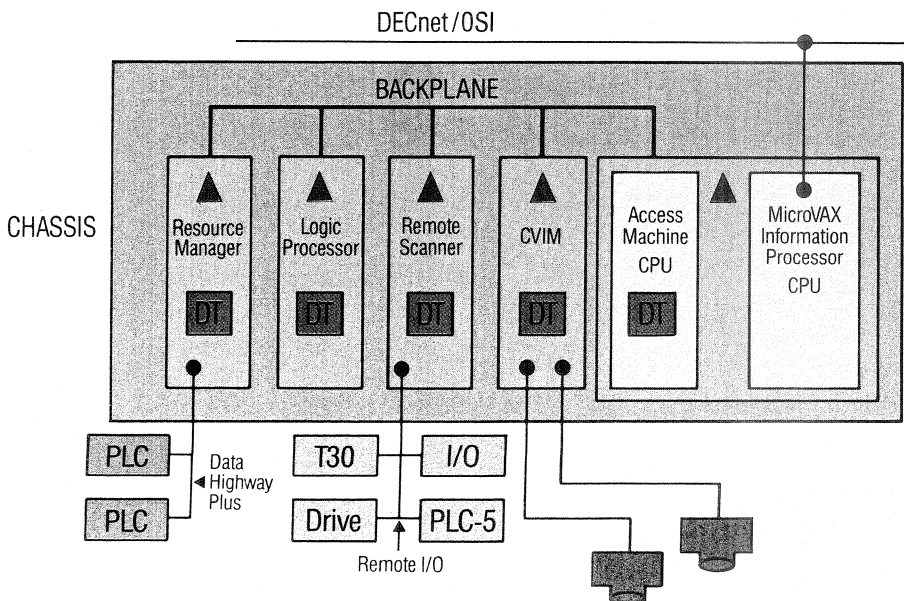

*This diagram illustrates how the Pyramid Integrator modules communicate with each other via the common backplane. Built into the MicroVAX Information Processor is an Access Machine CPU. Real-time information is collected by the Access Machine CPU from the data tables in the other modules. This data is placed into the MicroVAX's global memory and is used by the module's Application Program. Offloading the MicroVAX's CPU frees more system resources for execution of user Application Programs.*



# INTEGRATING THE FLOW OF INFORMATION

The MicroVAX Information Processor puts the powerful capability of a VMS processor directly within the information-gathering capabilities of the Pyramid Integrator. Here are some of the ways that this information processor integrates the much-needed connection between the control and information worlds.

MicroVAX Information Processor benefits include:

### INCREASED ACCESS TO APPLICATION SOFTWARE

The MicroVAX Information Processor has access to a broad range of VMS application software from Digital, Allen-Bradley and third-party software vendors.

### SIMPLIFIED CONTROL SYSTEM CONNECTIONS

The DECnet port built into this module provides DEC users with a very convenient gateway into Allen-Bradley architecture.

### TIGHTENED COUPLING WITH EXISTING CONTROL SYSTEMS

By using the Pyramid Integrator's common backplane, the MicroVAX processor achieves a tight coupling with the PLC-5/250 controller and CVIM vision modules.

### REDUCED INSTALLATION AND INTEGRATION COSTS

Because the MicroVAX Information Processor resides in the industrially-hardened Pyramid Integrator chassis, the added cost of a separate computer installation has been eliminated. And because the Data Table Library already integrates the module's software, these costs are also reduced. Finally, the module's DECnet port simplifies communication integration, reducing these costs as well.

*Application software for the center, cell, and station level functions listed here are available for use with the Pyramid Integrator.*

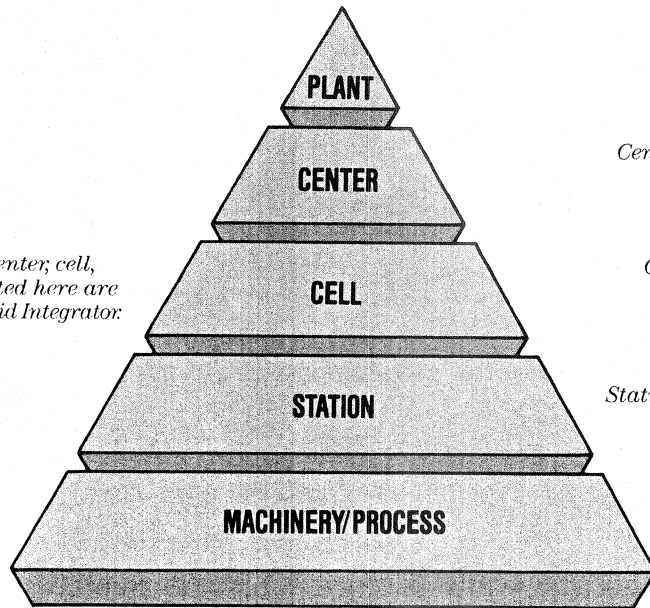

*Center: Distribution, Quality Management, Maintenance Management, MRP II*

*Cell: Alarm Management, Product Monitoring, Shop Floor Control, SPC, SQC, Scheduling*

*Station: PLC Program Development*

## RESPONDING TO INDUSTRY NEEDS

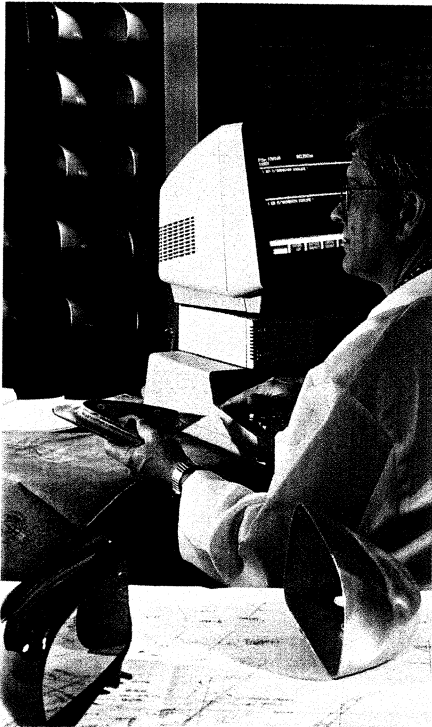

The Pyramid Integrator makes system-wide horizontal and vertical integration of the manufacturing process a reality.

This illustration shows three configurations of the Pyramid Integrator providing a direct link via DECnet and Data Highway Plus communications networks. Plant level operations (Management, Engineering, Maintenance) may send instructions to and receive information from Cell, Station and Machinery/Process level operations through a single, or several Pyramid Integrators.

On the left (A), a Pyramid Integrator oversees a variety of Allen-Bradley controllers including a PLC-5/250 used as a stand-alone. In the center (B), a Pyramid Integrator oversees controllers, operator interfaces, as well as a CVIM vision system. On the right (C), a Pyramid Integrator gathers data from a variety of controllers and operator interfaces using Allen-Bradley's Remote I/O network. A CVIM vision system also relays data via DECnet.

The Pyramid Integrator is the result of listening carefully to the needs of our customers. *It truly represents a breakthrough for achieving new levels of manufacturing efficiencies.*

### TIMELY ACCESS TO INFORMATION

Because it does integrate the information and control worlds, the Pyramid Integrator makes system-wide horizontal and vertical integration of the manufacturing process a reality. From the plant floor to data processing, the Pyramid Integrator can provide more accurate, more usable information in real time.

### IMPROVED QUALITY CONTROL

The Pyramid Integrator helps improve quality control by distributing computing power

to the place where manufacturing data originates—the plant floor. Instant access to this data is the key to real-time process control.

### INCREASED PRODUCTIVITY

With the Pyramid Integrator, it takes less time to produce more and higher quality products. The tight coupling of control data and computing power in one chassis reduces the need to network cables, resulting in faster information generation. Together, these features add up to increased productivity.

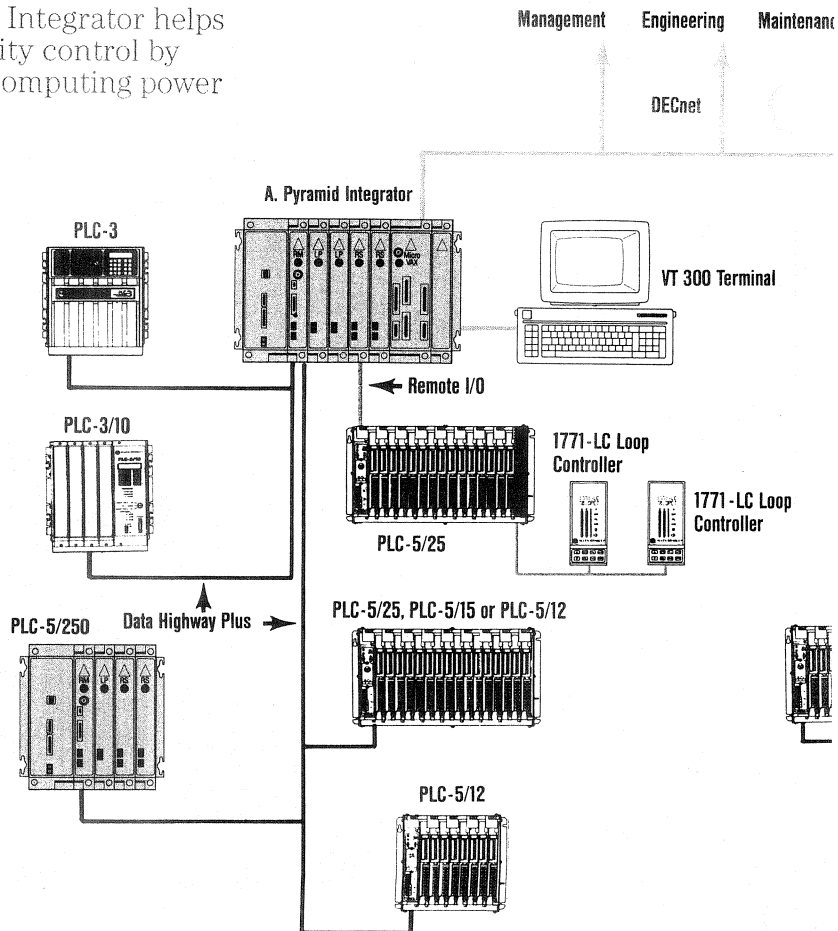

## INCREASED PRODUCTION RATES

The reduction in control system bottlenecks also results in a faster, smoother flow of information between levels, and from the beginning of the production cycle to the end.

## LOWERED SYSTEM LIFE CYCLE INVESTMENT

The Pyramid Integrator lowers the overall investment in a system's life cycle by:

- *Reducing software and hardware integration costs.* Software integration is provided by the Data Table Library for access to data tables in the modules. It also converts data between PLC and VMS formats. Hardware integration is simple and fast because of the Pyramid Integrator's modular design and common backplane.
- *Reducing application development costs.* VMS has an extensive

library of program development tools that help programmers build, test and maintain application programs quickly. Existing VMS programs will run on the MicroVAX Information Processor. The PLC-5/250 controller leverages existing investments in PLC-5 training and development. And for vision applications, the CVIM module offers simple configurations using icons and menus instead of time-consuming custom programming.

- *Reducing maintenance costs.* Common system-level components reduce the number of spare parts needed for stocking. And backplane communication means fewer external connections, along with fewer networking and cabling problems.

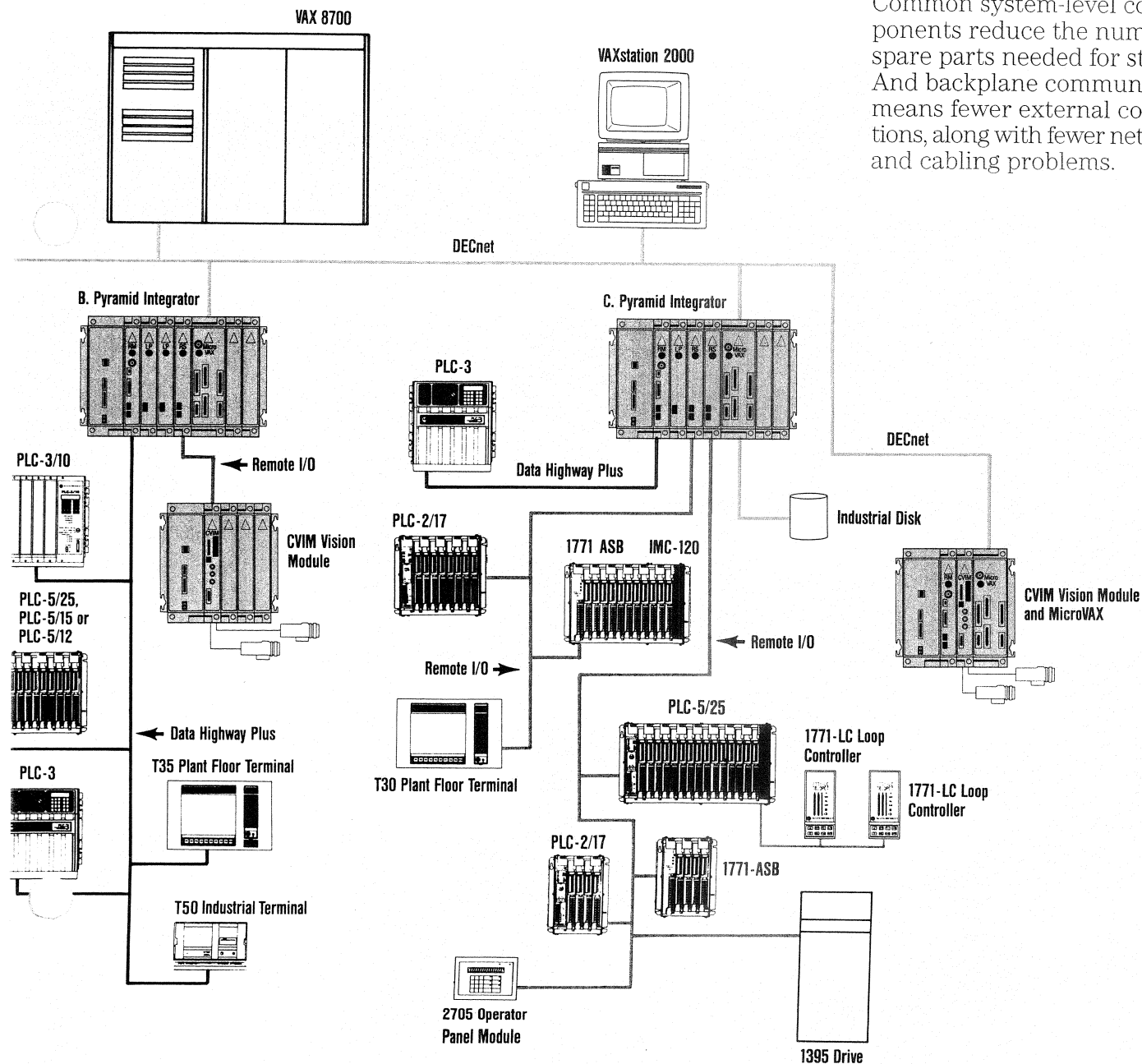

▲  
**PUT THE  
PYRAMID INTEGRATOR  
TO WORK TODAY**

The Pyramid Integrator is ready to help your company gain the competitive edge in today's marketplace. Whether you're fully integrating today or upgrading for the future, the Pyramid Integrator can meet your specific application needs. And, just as importantly, it can grow as your company grows.

**A TRADITION FOR OUTSTANDING SERVICE**

The Pyramid Integrator enjoys the same Allen-Bradley tradition for outstanding service to our customers. All components within the Integrator are serviced by experienced Allen-Bradley personnel. And this service extends to all Allen-Bradley control products as well.

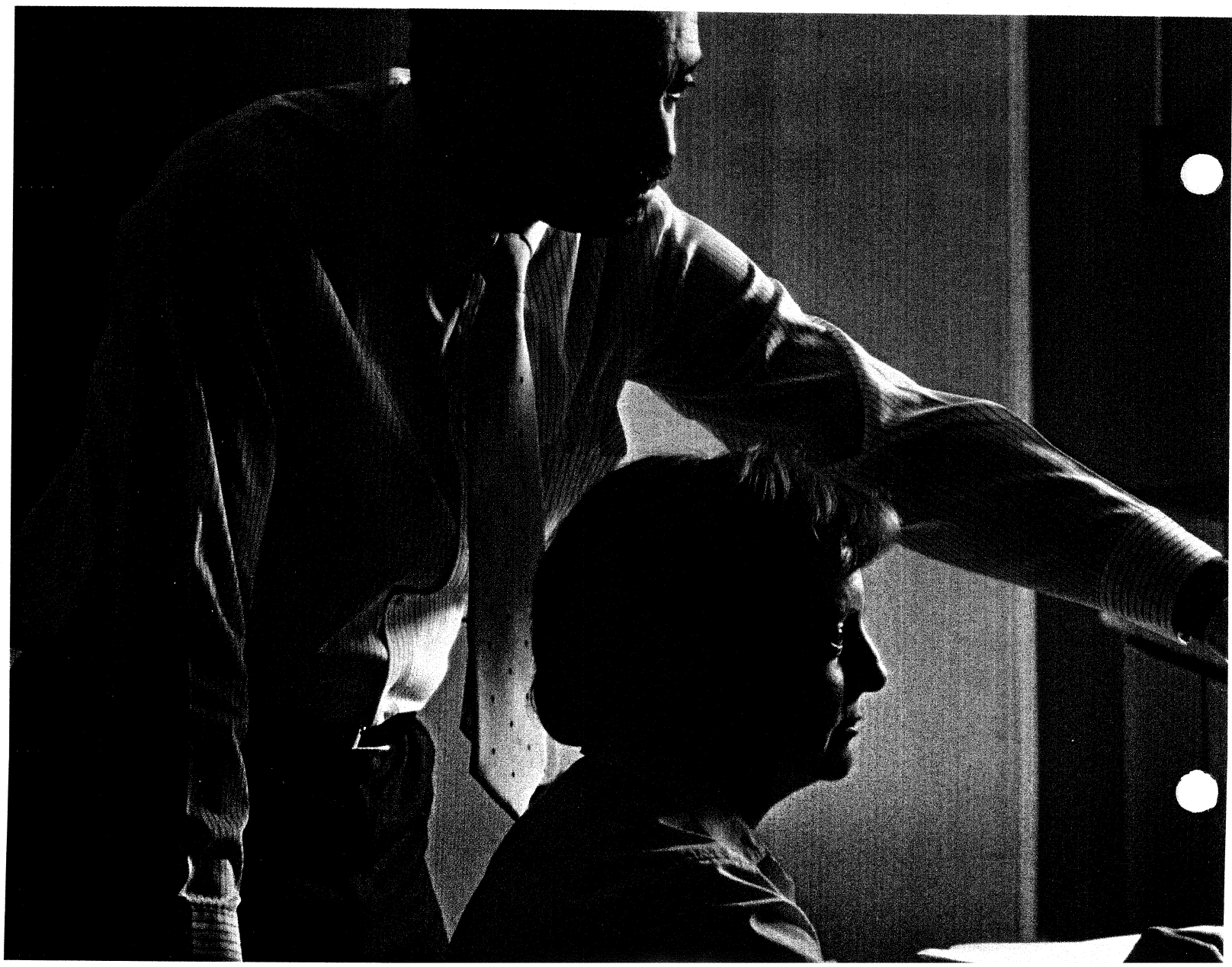

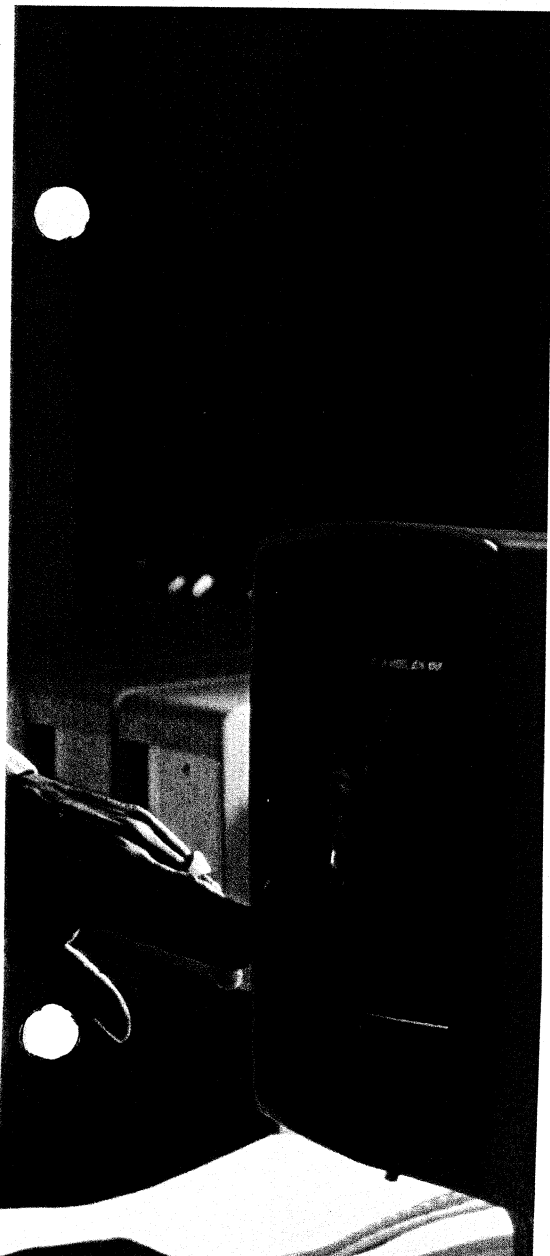

#### **FOR MORE INFORMATION**

For more information about the Pyramid Integrator or any of Allen-Bradley's products, write to:

Allen-Bradley  
Commercial Services  
747 Alpha Drive  
Cleveland, OH 44143

Pyramid Integrator and CVIM are trademarks of Allen-Bradley Company, Inc. PLC is a registered trademark of Allen-Bradley Company, Inc. VAXcluster, MicroVAX, VAX, DECnet, and VAXstation are trademarks of Digital Equipment Corporation.

*The Pyramid Integrator provides real-time access to important plant floor information.*



**ALLEN-BRADLEY**  
A ROCKWELL INTERNATIONAL COMPANY

With offices in major cities worldwide.

---

**WORLD HEADQUARTERS**  
1201 South Second Street  
Milwaukee, WI 53204 USA  
Tel: (414) 382-2000  
Telex: 43-11-016  
FAX: (414) 382-2400

**EUROPE/INDIA/MIDDLE EAST/  
AFRICA HEADQUARTERS**  
Allen-Bradley  
International Limited  
Chiltern House  
45 Station Road  
Henley-on-Thames  
Oxon, RG9 1AT England  
Tel: (44) 491-577013  
Telex: (851) 849782  
FAX: (44) 491-578933

**ASIA/PACIFIC HEADQUARTERS**  
Allen-Bradley (Hong Kong) Limited  
2901 Great Eagle Center  
23 Harbour Road  
G.P.O. Box 9797  
Wanchai, Hong Kong  
Tel: (852) 5-739391  
Telex: (780) 64347  
FAX: (852) 5-745326

**CANADIAN HEADQUARTERS**  
Allen-Bradley Canada Limited  
135 Dundas Street  
Cambridge, Ontario N1R 5X1  
Canada  
Tel: (519) 623-1810  
Telex: 069 59317  
FAX: (519) 623-8930

**LATIN AMERICAN  
HEADQUARTERS**  
1201 South Second Street  
Milwaukee, WI 53204 USA  
Tel: (414) 382-2000  
Telex: 43-11-016  
FAX: (414) 382-2400