

# Form 4C Recloser Control

*Microprocessor-Based  
Digital Communications  
Keyboard and Remote Programming  
Data Port  
Extensive TCC Selection  
Supervisory Operation  
Current Metering  
Event Recorder  
Recloser Duty Monitor  
Load Profile Monitor*

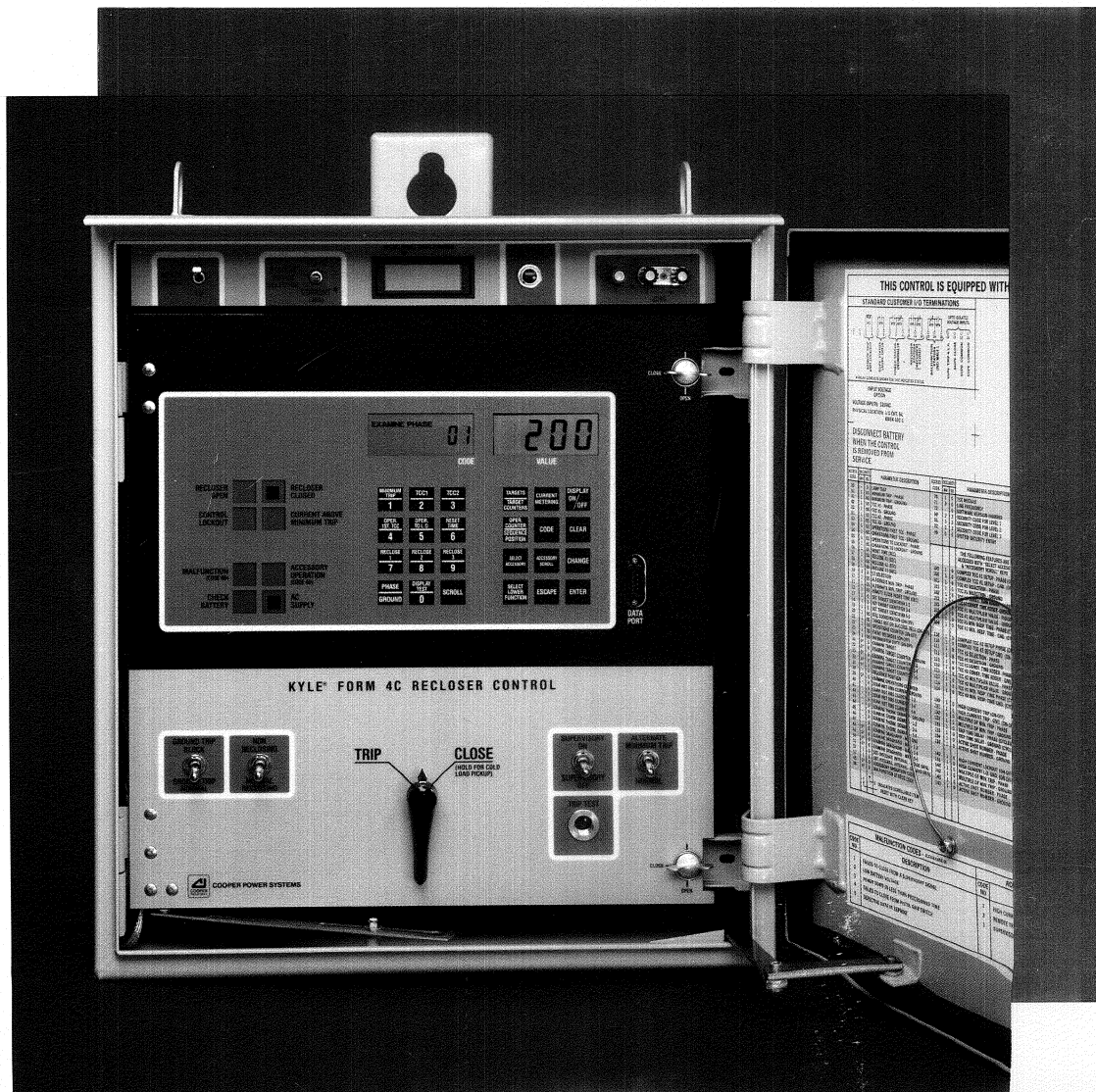

## **Form 4C Microprocessor-Based Recloser Control Provides:**

- **Sophisticated Features**
- **Ease of Operation**
- **Convenient Data Collection**

The Kyle® Form 4C microprocessor-based recloser control (Figure 1) provides the operational intelligence for Kyle's entire line of three-phase electronically controlled reclosers, ranging from 2.4 through 38 kV.

It combines sophisticated data collection capabilities and microprocessor flexibility with the dependability and ease of operation that have made Kyle recloser controls the first choice of the electric utility industry for nearly thirty years.

The Form 4C control offers a broad range of capabilities that provide complete distribution system protection and control:

- Phase-and-ground overcurrent detection.
- Unparalleled application flexibility provided by the wide choice of minimum trip settings, time current curves, and other operating settings.
- Keyboard interrogation and programming of all operating and accessory settings and parameters — all without the need for plug-ins and resistors.
- Keyboard scrolling of all control functions, settings, and parameters.
- Front panel interrogation and testing of battery condition.
- Three levels of security to ensure that only authorized personnel can access and change control operating characteristics.

### **Standard Form 4C Control Features**

The Form 4C control is equipped with many sophisticated features that provide application flexibility, supervisory operation, and event recording; all contained in a control designed for reliability and ease of operation.

Standard features of the Form 4C control include:

- Data port ... permits control's programming and stored data files to be downloaded to a portable hand held Data Reader or personal computer. Also allows control to be programmed directly by a PC.
- Event recorder ... records and displays event history information which includes date, time, and

current levels on all three phases and ground for 50 events in 11 event categories.

- Recloser duty monitor ... measures, calculates, records, and displays recloser interrupter duty factor for each individual phase.
- Load profile monitor ... records the RMS current value for each phase and ground at 15-minute intervals and displays data stored for the most recent 24 hours.
- Demand metering ... displays instantaneous and integrated line current and zero sequence current values over 5- or 15-minute intervals and peak demand (drag-hand) values.
- Sequence coordination ... prevents unnecessary operation of the backup recloser for a fault beyond a downline recloser.
- Phase and ground fault target indication and counters ... displays visual identification and count of all fault-initiated trip operations.
- Contact position indicator ... display provides visual indication of recloser contact position.
- Battery test panel ... displays battery voltage for open circuit and load testing as well as charging and discharge current.
- Low-current ground trip ... provides 5 amp ground fault sensing and tripping.
- High current lockout ... automatically shortens the control sequence above a predetermined fault level.
- High current trip ... provides tripping of the recloser with a choice of time delays (1 through 9 cycles) for both phase and ground on fault-level currents above a predetermined level.
- Minimum response time ... prevents simultaneous tripping of in line devices by inhibiting tripping until a predetermined time has elapsed.
- Trip test ... verifies trip and reclose operation of the recloser and reclose and reset timing of the control.
- Alternate minimum trip ... provides local selection of alternate phase and ground minimum trip value.
- Supervisory close ... allows supervisory closing of recloser through customer-supplied signal.
- Supervisory trip and lockout ... provides supervisory tripping of recloser through customer supplied signal.

- Supervisory operation via momentary contact ... provides supervisory operation with a momentary pulse contact instead of a maintained contact.
- Remote trip and lockout ... is essentially the same as supervisory trip and lockout except that it is unaffected by the supervisory on/off switch on the front panel of the control.
- Close-retry ... interrupts the closing signal to the recloser when closing power is lost. The number of retries is selectable from 1 to 5000 in increments of one. The close/reclose signal will be issued at 60-second intervals until closing power is restored or the control shuts down due to low battery voltage (minimum of 48 hours).

NOTE: This feature is similar to the KA531ME4 fuse elimination accessory on Form 3A controls. With close-retry, the block-of-close accessory KME4-66 is not required to provide protection during low voltage or loss of voltage conditions.

- Non-reclose operation ... when selected either from front panel switch or supervisory, the control will operate in accordance with TCC #1 for phase and ground, independent of the programmed sequence of operations.
- Ground trip precedence ... (On or Off). With ground trip precedence On, a ground fault above the phase minimum trip level will cause the control to operate on the ground trip operations to lockout setting. With the feature Off, the control will operate on the phase trip operations to lockout setting for any fault current (phase or ground) above the programmed phase minimum trip level.

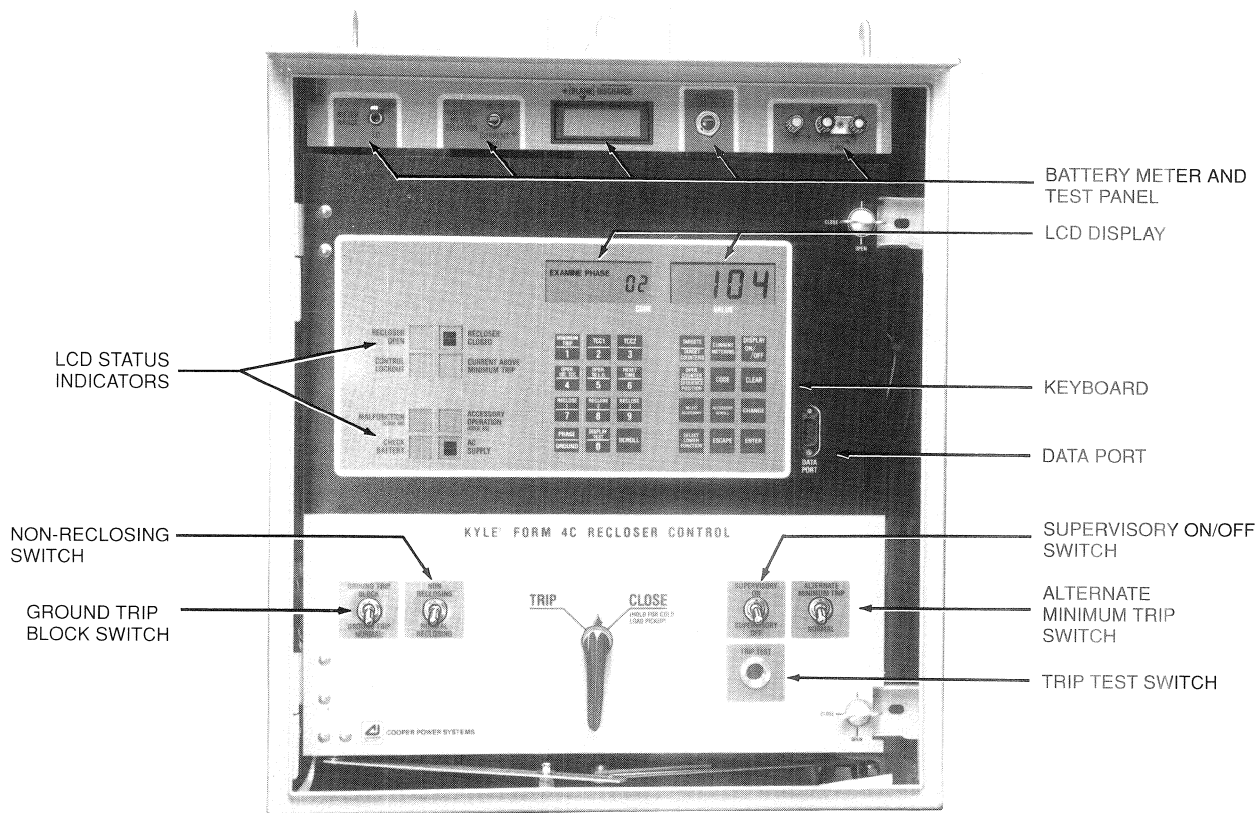

**Figure 1**  
**Kyle<sup>®</sup> Form 4C microprocessor-based recloser control front panel.**

### Programmable Settings

The Kyle Form 4C recloser control incorporates microprocessor technology to provide versatility and ease of operation. Operating personnel use simple keyboard programming techniques to establish the control's operating settings - ending the need to inventory the numerous trip resistors and plug-in components needed to change electronic control parameters on the Form 3A control.

All Form 4C control program settings, parameter descriptions, and programming access codes are conveniently listed on the control information label, located inside the cabinet door.

The Form 4C control can also be programmed with a personal computer connected to the control's front panel data port. The various control parameters that can be easily programmed are:

- Phase - (50 to 1600 amps) and ground fault (5 to 800 amps) minimum trip level.

- Phase and ground time - current curve selection from a total of 38 separate timing curves.
- TCC shape (vertical shift and constant time adder).
- Reclose interval (0.6 to 45 seconds).
- Reset interval (3 to 180 seconds) — reset on successful reclose.
- Number of operations to lockout (1, 2, 3 or 4).
- Number of operations on first phase and ground TCC (1, 2, 3 or 4).
- Standard feature and accessory selections (On or Off).
- Standard feature and accessory

settings.

All these changes can be made easily and quickly through the front-panel keyboard with its LCD display. A four digit security code, must be entered by the operator and verified by the microprocessor before additions or modifications are accepted, to prevent unauthorized programming changes.

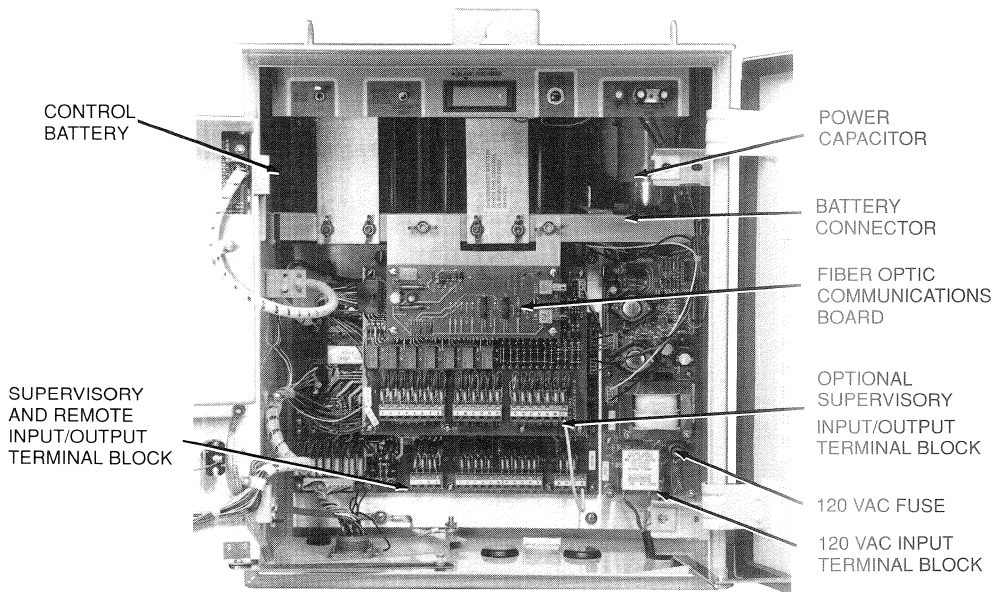

**Figure 2**  
Inside back panel of Form 4C control.

### Back Panel of Control

The control battery, cabinet heater, power supply, and customer connection terminal strips for the standard input/output board, the optional supervisory input/output accessory board, and the fiber optic digital communications accessory board are located inside the control cabinet, as shown in Figure 2.

### Data Port on Control Front Panel

The Form 4C control is equipped with a Data Port located on the control front panel. The data port permits the operator or technician to download all the programming information stored in the control, including event recorder, duty monitor, demand metering, and load profile monitor data, by plugging a Data Reader (shown in Figure 3) or personal computer (shown in Figure 6) into the data port. The data port provides a reliable and convenient means for data collection, compared to manual interrogation procedures at the control keyboard.

### Downloading Control Programming to a Data Reader

The Data Reader (shown in Figure 4) is used with the Cooper Power Systems Form 4C recloser control and CL-4B and CL-4C regulator controls. Information gathered from recloser and regulator controls installed on the

distribution system is stored in the data reader for later downloading into a personal computer for easy readout or analysis in spreadsheet programs. The diagram in Figure 5 illustrates that process. A single Data Reader can collect and store data from 100 regulator controls or 20 Form 4C controls, or any combination of readings from the two types of controls.

### Downloading and Programming the Form 4C With a Personal Computer

A personal computer can be connected directly to the Form 4C data port to permit downloading of data from the control into the computer (as shown in Figure 6). The PC can also be used to upload all control parameter settings into the control for convenient reprogramming. This allows the complete set of operating parameters to be programmed and verified at the headquarters location. Then, with the use of a laptop computer, a technician can upload the new operating program into the control at the installation site in just a few minutes.

This procedure saves technician time, reduces programming effort, provides detailed records, and eliminates the possibility of manual keyboarding errors. Programming data for each control is stored on disk in the computer and can be

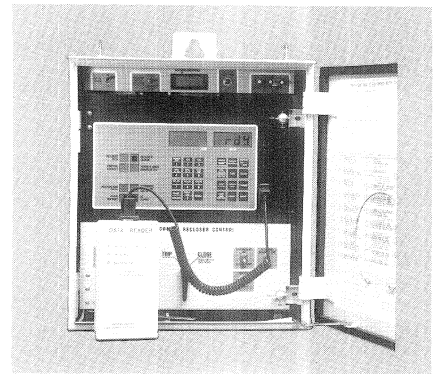

**Figure 3**  
Data Reader plugs into Data Port on Form 4C control panel to permit collection and storage of all the control's programming information and stored data files.

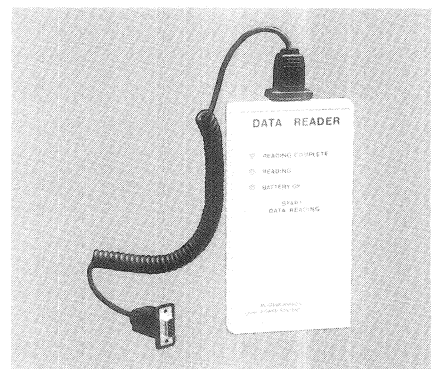

**Figure 4**  
Data Reader can store programming information and data files from as many as 20 Form 4C controls prior to downloading into a personal computer for analysis.

printed out and archived for future reference. A printout of each control's program settings can also be kept at the installation site for handy reference during future inspections. A data port-to-computer interface cable is available to permit connection of a personal computer to the data port on the front panel of the Form 4C control.

### Control Interface Software Program

The Form 4C INTERFACE™ software program is available to enable the control to be programmed and operated with a personal computer. It is used to send and receive data from the control and to provide access to the Data Reader's data files.

Form 4C INTERFACE software permits complete uploading and

downloading of all data stored in the control. It includes a database manager that allows the operator to import, export, or delete data, such as control settings and data records from the database. It enables the user to print various reports and it provides organized menus of data including; all control programming parameters, event recorder information, load profile records, demand metering records, and duty cycle monitor data. The software also allows the user to operate the control directly.

The program is easy to use and does not require extensive computer experience. System "help" screens are provided to assist the operator and the software package includes a comprehensive user's manual.

The Form 4C INTERFACE program can be used on any IBM PC (XT, AT, PS/2) or fully compatible computer with at least 640K of RAM memory.

### Digital Communications Accessory For SCADA Interface and Remote Operation

The Form 4C control has the capability for full-duplex (two-way), digital communications from a remote terminal (RTU), telephone modem, or central computer. This digital communications interface provides direct, on-line, real-time data acquisition and control. A pair of type ST fiber optic connectors is mounted on the fiber optic communication accessory board, located on the inside back panel of the control (shown in Figure 2). An RS232-to-fiber optic converter is supplied for the communications system interface.

With this communications capability, an operator at a remote location can monitor the status of the control and display control data such as: control programming settings, event recorder records, load profile, demand current metering, and recloser duty monitor information. The operator can remotely open or close the recloser for purposes of load balancing or system reconfiguration. The control can also be remotely reprogrammed to meet changing system requirements. That can be a significant benefit, since it eliminates the time and the expense of sending a technician to the installation site.

### Digital Communications Protocol

A Cooper Power Systems digital

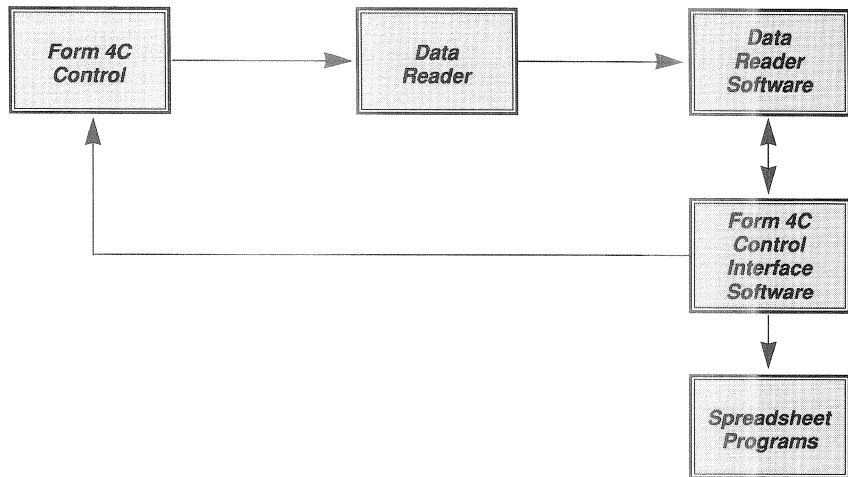

**Figure 5**  
Data flow using data reader software and Form 4C control interface software.

communications protocol is provided, with the necessary error bit and error message checking to ensure secure and reliable communications. This protocol was developed by Cooper Power Systems for use with the Form 4C recloser control, the CL-4C regulator control, and future Cooper Power Systems distribution system products.

The communications protocol also provides for addressability for connection of the Form 4C control in a party-line architecture, controlled by a single communications channel, by using the address feature. The protocol permits up to 200 unique

addresses on each party-line and provisions are also made for broadcasting messages to all controls simultaneously. For example; this feature can be used for resetting and synchronizing the clocks in all the controls on the party-line.

The protocol operates on data bases which are unique for each particular control in the Cooper Power Systems family of control products. For additional information on the Form 4C Digital Communications Protocol refer to *Reference Data R280-90-9*. And, for additional information on the Communications Point Data Base, refer to *R280-90-10*.

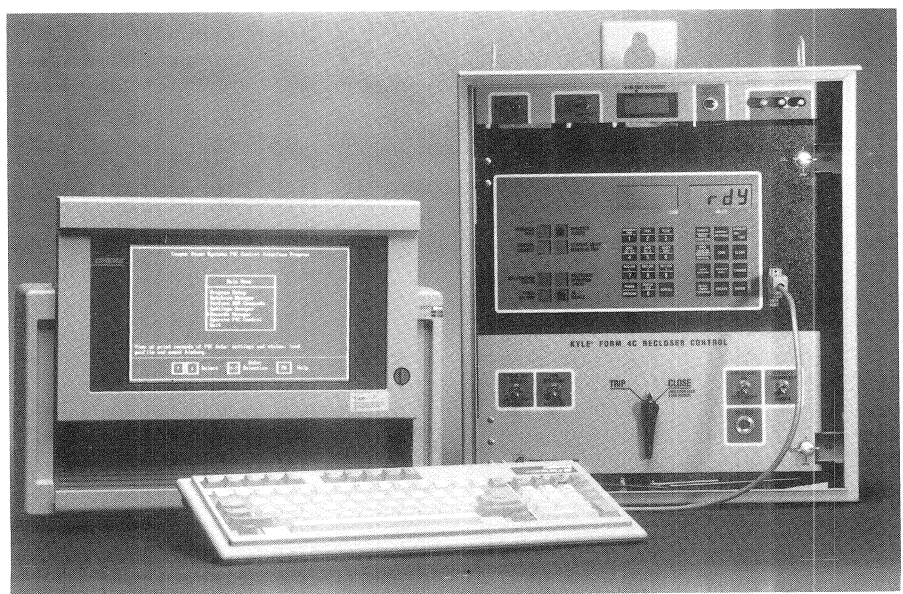

**Figure 6**  
The Form 4C control can be programmed directly from a laptop computer.

## Control Panel Keyboard and LCD Display

The Form 4C control has a keyboard with 24 keys and a large daylight visible LCD display. The display is activated by pressing the DISPLAY ON/OFF key. It will remain on until the key is pressed again, or it will shut off automatically ten minutes after the last keyboard entry is made.

### Easy-To-Use-Keyboard

The full function dual pad keyboard (shown in Figure 7) features dedicated function select keys to simplify operator interrogation of the most common control parameters and functions.

For example, to display all the standard control parameters, it is only necessary for the operator to depress the DISPLAY ON/OFF key and the SCROLL key. Each subsequent touch of the SCROLL key will display the next parameter sequentially.

To display a specific function without the need to scroll through the entire list of parameters for each function, press the SELECT ACCESSORY key until the desired function title is displayed. Then, press ACCESSORY SCROLL to display the desired parameters for that function.

## Keyboard Functions Left Side of Keyboard

The left hand portion of the keyboard contains ten lower function numeric keys (0 through 9). During programming operations, when the control is ready to accept numerical values, these keys may be used without pressing SELECT LOWER FUNCTION.

**MINIMUM TRIP** permits the operator to display the phase and ground minimum-trip values.

**TCC1** and **TCC2** are used to display the code numbers of the first and second time-current curves for phase and ground. If the curve has been modified through the use of a constant time adder and/or vertical shift multiplier, a "c" will appear in front of the displayed number of the curve (See Table 4 for available time-current curves.)

**OPER 1ST TCC** displays the programmed number of trip operations on the first time-current curve for phase and ground.

**OPER TO L.O.** displays the number of programmed operations to lockout for phase and ground (1, 2, 3 or 4).

**RESET TIME** - Displays programmed reset after successful

reclose delay time (3 to 180 seconds).

**RECLOSE 1, RECLOSE 2** and **RECLOSE 3** display programmed reclose delay times after first, second and third trip operations (0.6 to 45 seconds in 0.1 second increments). The second and third reclosing times must be equal to or greater than 2.0 seconds.

**PHASE/GROUND** is used to select either phase or ground; TCC, minimum trip, operations to lockout, and operations on first TCC.

**DISPLAY TEST** is used to check the operation of the LCD's.

**SCROLL** allows the operator to scroll through and display the programmed values of common control operating features.

## Keyboard Functions Right Side of Keyboard

Certain functions can be displayed by pressing a single dedicated function select key. For example, to read fault target information after a control lockout, press **TARGETS**.

The lower function of the **TARGETS/TARGET COUNTERS** key displays a numerical total of all fault current trip operations for each phase and ground.

**CURRENT METERING** displays load current and demand meter readings.

**DISPLAY ON/OFF** is used to turn the keyboard LCD display on. When pressed, the display is activated, the RDY (Ready) prompt appears and the control is ready to accept interrogation or programming. Pressing the key again will turn off the display. The display will also shut off if unused for ten minutes after the last keyboard entry.

**OPER COUNTER/SEQUENCE POSITION** - displays the total number of control trip operations. The lower function of the key provides a readout of the control position in the operations-to-lockout sequence.

**CODE** key allows direct entry of access codes for interrogation or programming of control features and parameters.

**CLEAR** allows operator to clear pending keyboard entries, and resets targets, counters and demand drag hand.

**SELECT ACCESSORY** is used to scroll through the various control features with programmable parameters.

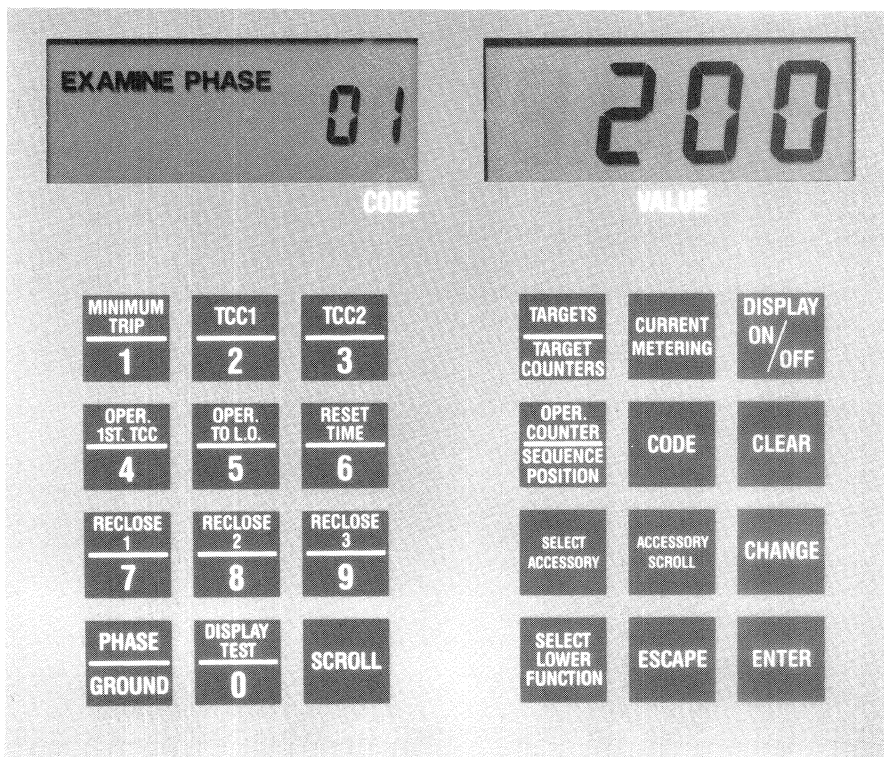
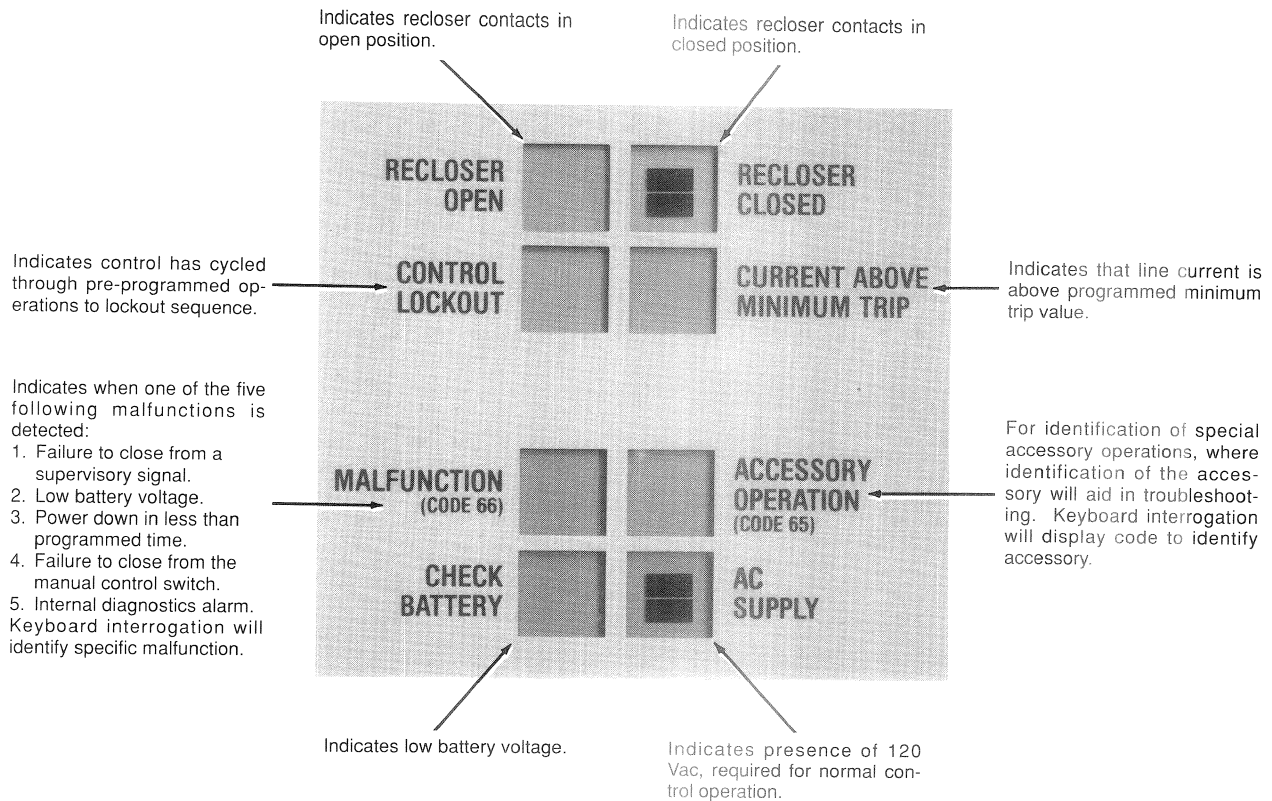

Figure 7  
Form 4C keyboard with LCD display



**Figure 8**  
Control panel LCD indicators provide control and recloser status information.

**ACCESSORY SCROLL** displays individual parameters of each control feature for interrogation or programming.

**CHANGE** key allows change to programmed values and parameters of control features and accessories.

**SELECT LOWER FUNCTION** is used to access the lower case key functions.

**ESCAPE** allows operator to return the display to the RDY (Ready) prompt during programming and to clear pending keyboard entries. It also may be used anytime the operator wishes to return to the RDY prompt during interrogation of the control.

**ENTER** key is used to enter an access code or changed parameter into the control program.

### Control Panel LCD Status Indicators

Eight LCD status indicators (Figure 8), located to the left of the keyboard and display, provide status information on various control and recloser functions. These indicators let the operator know at a glance whether the recloser is open or closed. They also provide indication of control lockout, current above programmed minimum trip, status of 120Vac control power, low battery voltage, control malfunction and accessory operation.

## Manual Operating Controls

The lower portion of the front panel of the Form 4C control (shown in Figure 9) contains manual operating controls.

### GROUND-TRIP BLOCK SWITCH

Blocks all ground tripping in the BLOCK position. Prevents unintentional tripping during single-phase switching operations.

### NON-RECLOSING SWITCH

Sets the control for one trip operation to lockout on the #1 phase and ground time-current curve, without changing the programmed operations to lockout sequence.

### SUPERVISORY ON/OFF SWITCH

In the OFF position prevents the operation of supervisory signals. In the ON position programming via the keyboard is disabled.

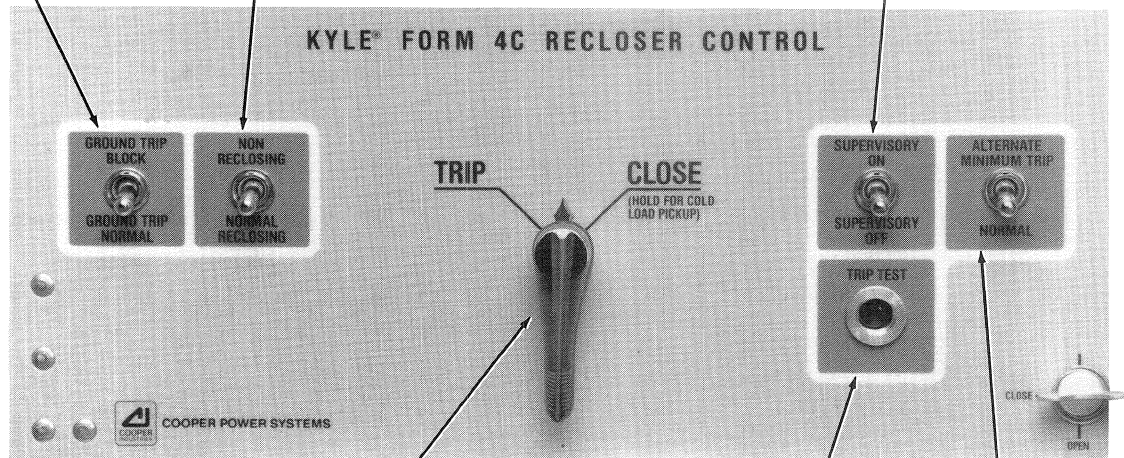

### MANUAL CONTROL SWITCH

In the TRIP position, it trips open the recloser and locks out the control. In the CLOSE position, it returns the control to the initial or home position and closes recloser. If held in the CLOSE position, it transfers all trip operations to the second programmed time-current curve (normally slower), to override inrush current.

### TRIP TEST SWITCH

Permits manual trip of control and recloser. Verifies trip and reclose of the recloser and reclose and reset timing of the control.

### ALTERNATE MINIMUM TRIP SWITCH

Permits switching to alternate programming phase and ground minimum trip values.

**Figure 9**  
Manual operating controls on the lower portion of the Form 4C control panel.

## Battery Test Panel

Located at the top of the front panel of the control, is the battery test panel (shown in Figure 10). The battery test panel contains switches, a meter display, and test points for checking the condition of the control's 24 volt lead acid battery.

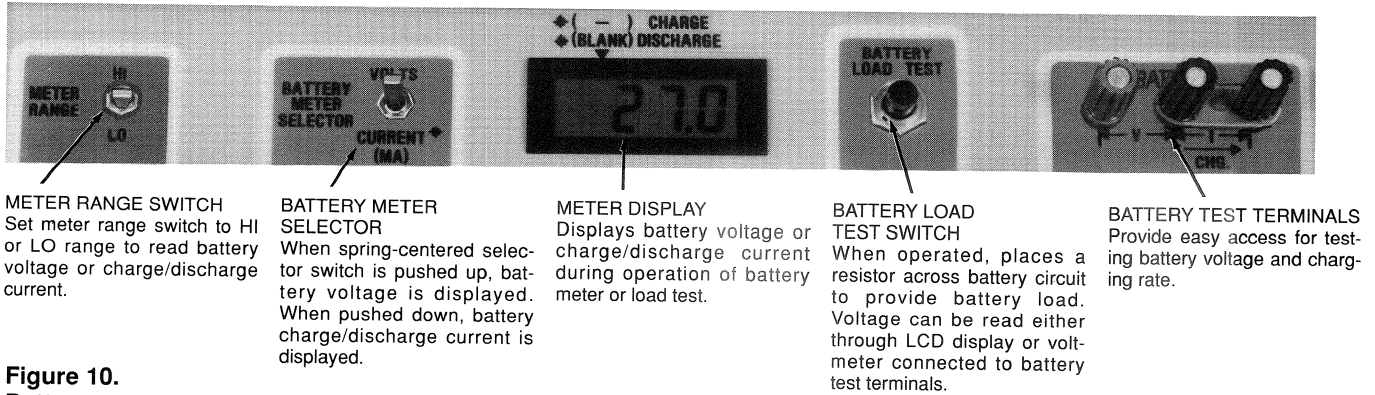

**METER RANGE SWITCH**  
Set meter range switch to HI or LO range to read battery voltage or charge/discharge current.

**BATTERY METER SELECTOR**  
When spring-centered selector switch is pushed up, battery voltage is displayed. When pushed down, battery charge/discharge current is displayed.

**METER DISPLAY**  
Displays battery voltage or charge/discharge current during operation of battery meter or load test.

**BATTERY LOAD TEST SWITCH**  
When operated, places a resistor across battery circuit to provide battery load. Voltage can be read either through LCD display or voltmeter terminals connected to battery test terminals.

**BATTERY TEST TERMINALS**  
Provide easy access for testing battery voltage and charging rate.

**Figure 10.**  
Battery test panel controls and meter display.

## Event Recorder

The Form 4C control is equipped with an event recorder to provide detailed event history data for system analysis. Event recorder data will indicate fault magnitudes, identify line maintenance needs through analysis of transient faults and permanent outages and point to methods for improving reliability. Event recorder data is accessible via the keyboard, Data Port, or Digital Communications accessory and includes the following:

- Non-volatile memory ... that stores the 50 most recent events.

- Time clock ... records month, day, hour, minute and second of each event.
- Separate current records ... for all three phases and ground. Current values are in RMS kiloamperes.
- Current range ... is from 0 kA to 30 times programmed minimum trip value. If fault current exceeds 30 times minimum trip, an over-range message will be displayed.

- Event type identification ... is provided. Eleven different event codes identify supervisory, remote, and local operation for trip, close and lockout as well as control reset and AC power loss/restoration. An example of event recorder data is shown in Figure 11. Figure 12 diagrams the corresponding recloser operations.

EVENT # (161)	EVENT TYPE (162)	MONTH/DAY (163)	HOUR/MIN. (164)	SECONDS (165)	CURRENT (K amps)			
					GROUND (166)	PHASE 1-2 (167)	PHASE 3-4 (168)	PHASE 5-6 (169)
1	2	2.17	14:20	:40	0.02	0.16	0.15	0.17
2	1	2.17	14:20	: 8	2.80	0.16	0.15	2.80
3	1	2.17	14:20	: 6	2.80	0.16	0.15	2.80
4	3	2.08	10:24	:15	0.00	0.00	0.00	0.00
5	1	2.08	9:21	:12	1.30	0.13	1.30	0.14
6	1	2.08	9:21	: 7	1.30	0.13	1.30	0.14
7	1	2.08	9:21	: 5	1.30	0.13	1.30	0.14
8	1	2.08	9:21	: 3	1.30	0.13	1.30	0.14
9	2	2.03	14:40	:49	0.02	0.15	0.15	0.16
10	1	2.03	14:40	:16	2.40	2.40	0.15	0.16
11	1	2.03	14:40	:14	2.40	2.40	0.15	0.16

EVENT TYPE	DESCRIPTION	EVENT TYPE	DESCRIPTION
1	Overcurrent Trip	6	Lockout—Remote
2	Reset	7	Lockout—Supervisory
3	Close—Manual Control Switch	8	Trip—Supervisory
4	Close—Supervisory	9	Loss of AC Voltage (minimum 2 min. duration)
5	Lockout—Manual Control Switch	10	Restoration of AC Voltage (.03 seconds)
		11	Sequence Coordination

**Figure 11**  
Event recorder data record.

SAMPLE RECLOSER OPERATIONS

CONTROL SETTINGS: 2 FAST, 2 DELAY TO LOCKOUT  
2, 2, 5 SEC. RECLOSING  
30 SEC. RESET

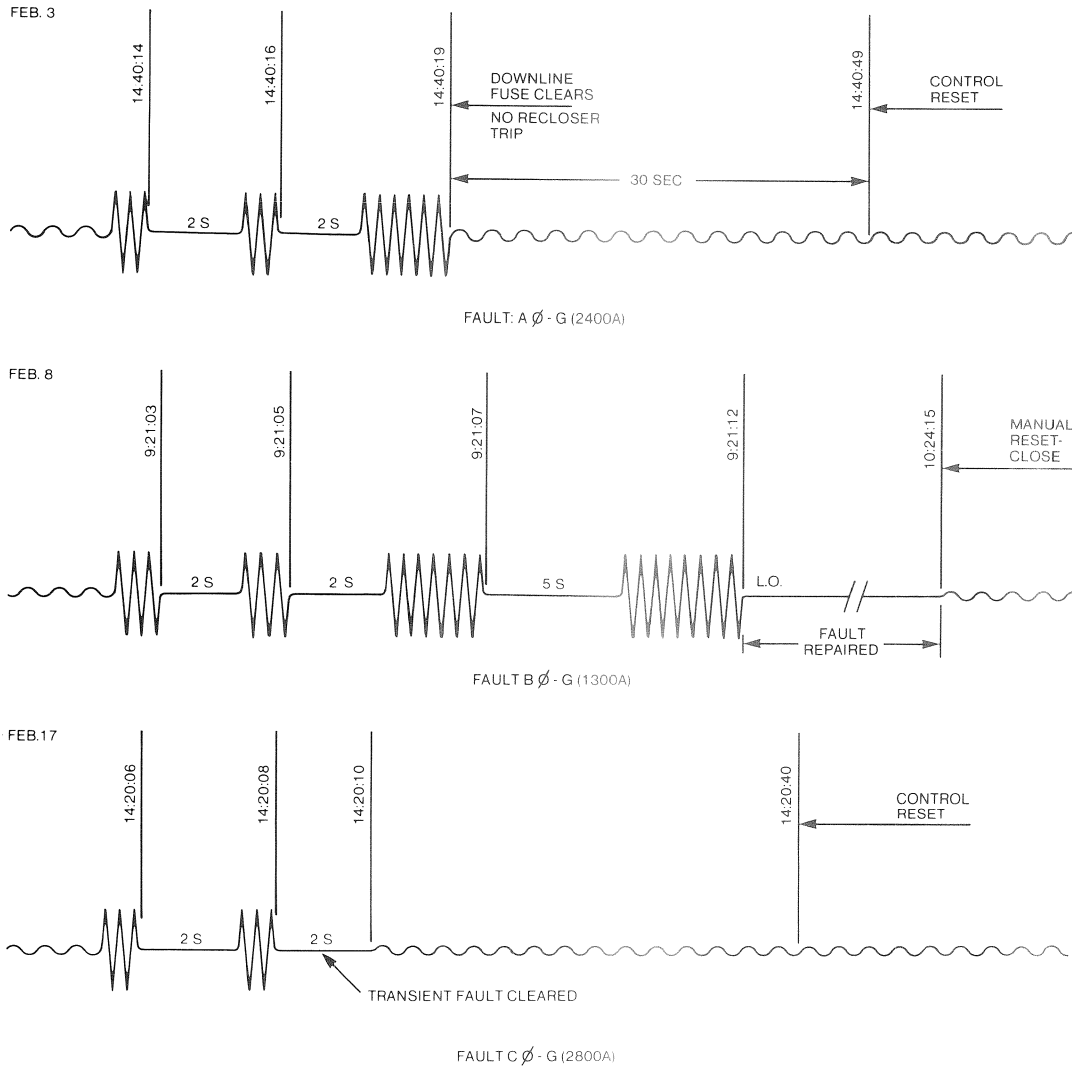

**Figure 12**  
Recloser operation diagrams corresponding to event recorder data record.

**Recloser Duty Monitor**

The Form 4C control includes a recloser interrupting duty monitor as a standard feature. The recloser duty monitor provides duty cycle information which is accessible via the keyboard, Data Port, or Digital Communications accessory, and includes the following:

- Measures and records duty for each individual phase in non-volatile memory.
- Duty is measured on the basis of  $I^{1.5}$ .

- Duty readout provided as percentage of total duty cycle.
- Duty record can be adjusted or reset (if recloser changed-out, etc.)

**Load Profile Monitor**

Load profile monitoring is a standard feature of the Form 4C control. RMS demand current values for each phase and ground are read, recorded and stored at 15 minute intervals in non-volatile memory. This data, along with the time in hours and minutes, is stored for the most recent 24 hours.

Load profile data is accessible through the keyboard, Data Port, or the Digital Communications accessory.

**Demand Metering**

Ampere demand metering is a standard feature on the Form 4C control. Metering data is displayed on the control panel LCD display. This eliminates the need for separate meters and BCT's by utilizing the standard 1000:1 current transformers already mounted within Kyle electronically controlled reclosers.

Demand metering information is accessible through the keyboard, Data Port, or the Digital Communications accessory, and monitors:

- Instantaneous line current values.
- Integrated current values over a selected time interval of 5 or 15 minutes.
- Peak integrated demand values (drag-hand function).
- Ground unbalance values (instantaneous, integrated, and peak).

The accuracy of all the metering functions is  $\pm 5\%$  of the programmed minimum trip level from 25% to 100% of that level.

### Standard Supervisory and Remote Operation Features

The Form 4C control includes a variety of standard supervisory and remote operation features that provide user convenience and improved system control. The Form 4C control is also equipped with contacts to provide remote status indication of various control and recloser functions.

The supervisory functions require externally provided power for operation and are controlled by the supervisory ON/OFF switch located on the front panel of the control. With the supervisory switch in the ON position, the supervisory functions are operative. With the supervisory switch in the OFF position, supervisory operation is blocked. The control can be tripped or closed via the front panel manual control switch, regardless of the position of the supervisory switch.

Standard supervisory, remote operation and remote indication features of the Form 4C control include:

- Remote trip and lockout ... can be used for emergency tripping from external alarms. It is similar to supervisory trip and lockout, except that its operation is not affected by the supervisory ON/OFF switch\*.
- Supervisory close ... initiates a closing signal to the recloser and modifies the operating sequence to one delayed trip to lockout for a selected time interval. After the time interval has elapsed, the control resets for a full sequence of operations\*.
- Supervisory trip and lockout ... trips the recloser and locks out the control. The control remains locked out until it is closed manually or by the supervisory close feature\*.
- Malfunction indicator ... provides a

dry contact (SPDT rated 1 amp at 120Vac) that operates to provide remote status indication when one of the five following malfunctions are detected:

1. Failure to close from a remote signal.
  2. Failure to close from the manual control switch.
  3. Low battery voltage.
  4. Internal diagnostics alarm.
  5. Power down in less than normal time.
- Power status indicator ... provides a dry contact (SPDT rated 1 amp at 120Vac) that operates to provide remote status indication when either of the following conditions exist:
    1. Low 120Vac input (below 90Vac).
    2. Low battery voltage.
  - Recloser status indicator ... provides a dry contact (SPDT rated 1 amp at 120Vac) that operates to indicate open or closed status of the recloser contacts.
  - Supervisory switch status indicator ... provides a dry contact (SPST rated 1 amp at 120Vac) that closes when the supervisory switch is in the ON position.

\*Operation requires customer-provided power; 120Vac, 12Vdc, 24Vdc, 48Vdc, or 125Vdc.

### Accessory Supervisory Input/Output Board

An optional supervisory I/O board is available for the Form 4C control to extend the supervisory operation capabilities of the control. The accessory I/O board also includes contacts to provide remote status indication of four additional control functions.

The supervisory functions require external power for operation and are controlled by the Supervisory ON/OFF switch located on the front panel of the control. The accessory I/O board features include:

- Supervisory trip ... provides the ability to trip the recloser from a remote signal. Normal reclosing operations will follow. Operation is permitted only when the front panel Supervisory switch is ON.
- Supervisory non-reclosing ... provides non-reclosing input by a remote momentary or maintained signal\*. Supervisory operation is dependent upon front panel Non-reclosing and Supervisory ON/OFF switch positions. Supervisory non-

reclosing sets the control to operate on the #1 phase and ground TCC, regardless of the control's programmed sequence of operation.

- Supervisory ground trip block ... provides supervisory operation of ground trip block by a remote momentary or maintained signal\*. Supervisory operation is dependent upon front panel Ground Trip Block and Supervisory ON/OFF switch positions.
- Supervisory alternate minimum trip ... provides selection of alternate programmed values for phase and ground minimum trip. Feature is actuated by a remote momentary or maintained signal\*. Supervisory operation is dependent upon front panel Alternate Minimum Trip and Supervisory ON/OFF switch positions.
- Remote lockout status indicator ... provides a dry contact (SPST rated 1 amp at 120Vac) to provide remote indication of control lockout.
- Non-reclose status indicator ... provides a dry contact (SPST rated 1 amp at 120Vac) to provide remote indication when the control is in the non-reclose mode from either the front panel Non-reclose switch or a supervisory command.
- Ground trip block status indicator ... provides a dry contact (SPST rated 1 amp at 120Vac) to provide remote indication when the control is in the ground trip block mode from either the front panel Ground Trip Block switch or a supervisory command.
- Remote fault target indicator ... provides separate dry contacts for remote indication of phase targets 1-2, 3-4, and 5-6.
- Alternate minimum trip status indicator ... provides a dry contact (SPST rated 1 amp at 120Vac) to provide remote indication when the control is in the alternate minimum trip mode from either the front panel Alternate Minimum Trip switch or a supervisory command.

\*Operation requires customer-provided power; 120Vac, 12Vdc, 24Vdc, 48Vdc, or 125Vdc. Momentary or maintained signal mode is programmable by customer.

### Time-Current Curve Selection

The Form 4C control is equipped with 38 time-current curves that are interchangeable for phase and ground and can be selected from the keyboard or remotely via the data port or digital communications accessory. This permits reprogramming of time-current characteristics without the need to change plug-in components. Form 4C time-current curves are contained in three keyboard accessible timing groups. Each timing group contains a selection of 21 TCC's. TCC's from one timing group are available for keyboard programming at any one time. For additional information on Form 4C time-current curves, refer to *Reference Data R280-91-34*.

Tables 3 and 4 list the TCC's in the Form 4C timing group and provide a cross-reference to their Form 3A control curve equivalents.

### Time-Current Curve Modification

In order to further enhance control flexibility and to offer an almost unlimited number of time-current curve selections, each TCC programmed into the control can be modified either vertically or with a constant time.

By simple programming, the basic TCC shape can be shifted vertically (Figure 13) by applying the desired multiplier. The available multipliers are 0.12 to 2.0 in increments of 0.01.

In addition, a constant time adder (Figure 14) of 0 to 0.2 seconds in increments of 0.01 seconds can further tailor each TCC to a customer's specific needs. All this with only keyboard programming. Modified TCC's will display a code ("c") when interrogated to let the operator know that the standard TCC has been modified.

### Block of Close Accessory

The block of close accessory permits control of any close or reclosing operations by blocking the closing signal. Block of close can be useful in loop schemes and load transfer applications. For example, it can prevent closing a tie recloser when both sources are energized. It can also act as an interlock to prevent closing under other undesirable conditions such as low voltage.

The control will not reset while block of close is activated, since reset timing begins only after reclosing and then only if no fault current is present.

The block of close accessory requires 120Vac for operation and can be factory connected to block closing while its low voltage supply is energized or de-energized.

NOTE: Since the control is equipped with the close-retry feature, the block-of-close accessory is not required to provide protection during low voltage or loss of voltage conditions.

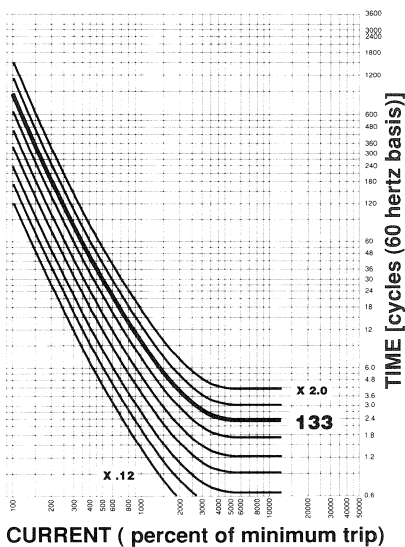

Figure 13  
TCC vertical shift modification examples.

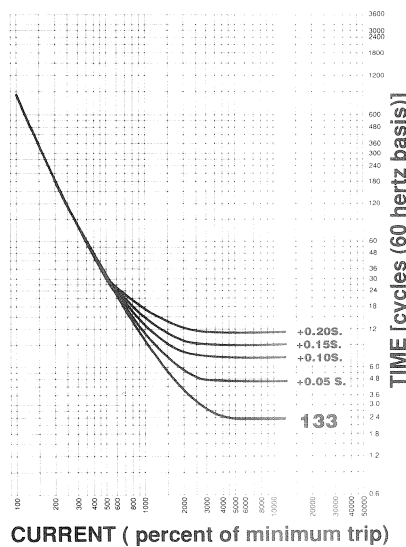

Figure 14  
Examples of TCC modifications with constant time adder.

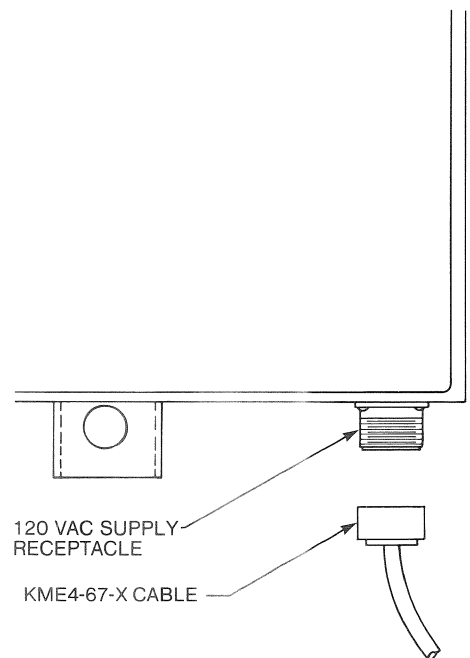

Figure 15  
120Vac supply receptacle accessory KME4-55.

## 120Vac Supply Receptacle and Supply Cable Accessories

The Form 4C control can be equipped with an input receptacle for the 120Vac supply required for control operation. The 120Vac receptacle accessory (Figure 15) provides a threaded three-pin male cable connector for connection to the KME4-67-X 120Vac supply cable accessory.

## Input Connection Box and Convenience Outlet Accessory

The Form 4C control can be equipped with an external connection box accessory (Figure 16) to provide a 120Vac convenience outlet and the option of a convenient connection point for cabling for low voltage closing. 120Vac power brought into the connection box is wired directly into the Form 4C control for ac control power

## Control Power

The primary source of power is 120Vac or 240Vac, which is rectified to charge the trip-close capacitor and to power a DC/DC converter that provides logic voltage to the control. Power to operate the tripping and reclosing solenoids in the recloser is provided by a capacitor located on the rear panel of the control. A 24-volt lead acid battery located in the upper portion of the back panel of the control cabinet is utilized to provide operating and tripping energy when 120Vac is temporarily lost. An internal 120Vac potential battery charger provides a continuous temperature compensated charge to the battery. The control can also be configured to operate with a backup DC power supply option to permit interface with a substation battery, in place of the standard control lead-acid battery.

## Operation Upon Loss of 120Vac

If the Form 4C control is equipped with the standard 24Vdc lead-acid battery (instead of the optional provisions for connection to a substation battery supply), the control will operate from the battery power supply for a minimum of 48 hours if 120Vac control power is lost. The control will shut down automatically upon detection of low battery voltage to prevent battery damage.

Local indication for loss of 120Vac is provided by the 120Vac Supply LCD indicator display on the front panel of the control. If low battery voltage is detected, the Malfunction LCD indicator will be activated to provide local indication of low battery voltage.

Restoration of 120Vac to the control will return the control to full operating level within approximately two seconds.

The control is equipped with a power status indicator contact for remote indication of power source (120Vac) or power supply (control battery) problems. If the ac control input voltage drops below 90Vac or if low control battery voltage is detected, the power status indicator relay contact will operate to provide a remote alarm.

## Control Security System

The Form 4C control has a three-level security system which limits customer personnel access to only those control functions appropriate to their responsibilities. It will prohibit unauthorized access to programming and operating parameters.

Interrogation of the control to display operating parameters and read-only functions of the control panel does not require entry of a security code.

First level security authorizes changing of operating parameters, such as minimum trip values, number of operations to lockout, time-current curves, etc. and requires the keyboard (or remote) entry of a four-digit security code. This customer-changeable code permits authorized reprogramming and prevents accidental changes to operating characteristics of the control.

The second level of security allows modification of the parameters of a group of special functions and requires the keyboard (or remote) entry of a 4-digit code. This security level is designed to be accessible only to personnel completely familiar

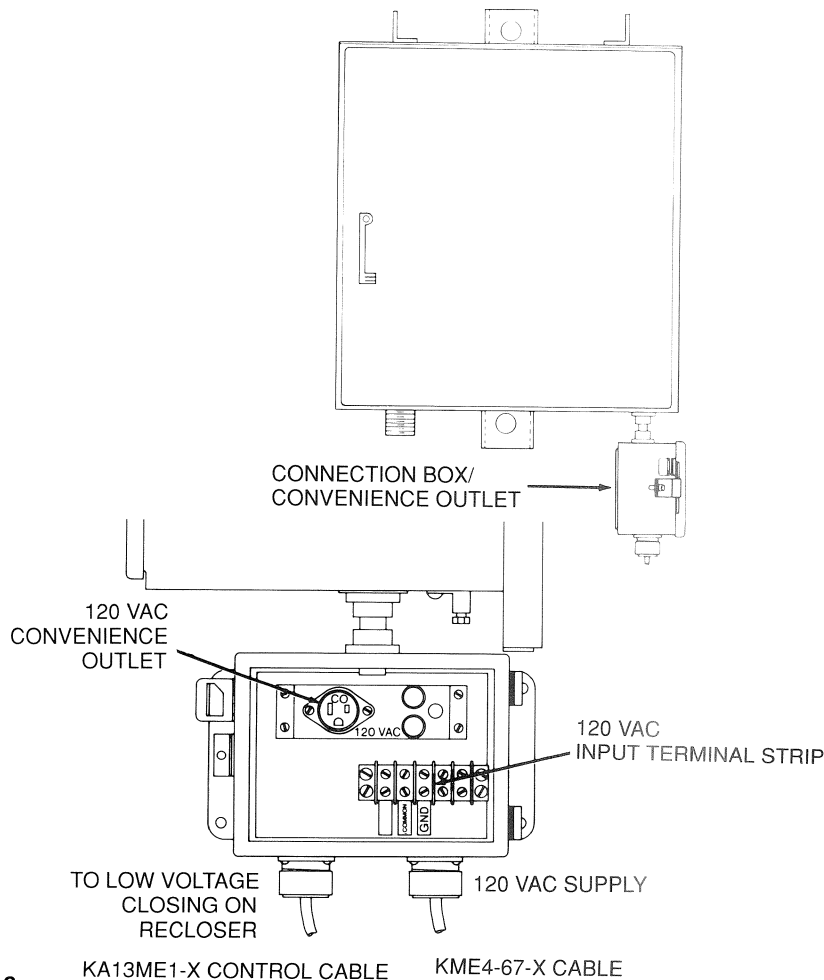

**Figure 16**  
**KME4-57-3 Input connection box and convenience outlet accessory.**

with the operation of these functions, since faulty programming could lead to improper operation of the control.

Security level three permits modification of security codes for security levels 1, 2 and 3 and allows access to special operating features.

### Housings

The standard Form 4C control is housed in a 16 in. x 18 in. x 11 in. weatherproof steel cabinet. It can also be housed in the upper half of a 16- x 35- x 11-in. double size cabinet when used with accessories or

auxiliary control equipment requiring additional mounting space. Both the standard size and the double size cabinets are available in stainless steel versions. Finish color is light gray, identical with the finish color of the reclosers.

A rainguard over the top of the door and perimeter door gasketing provide for weatherproof cabinet closing. A three-point latch ensures proper sealing pressure. The latch operating handle can be padlocked in the closed position. When open, the door is prevented from swinging in the wind by a hold-open latch.

### Control Testing

Operation of the Form 4C control can be tested with the Type MET electronic recloser control tester. The tester has the capability to check phase and ground minimum trip current, TCC's, operating sequence, reclosing time, reset time, and various accessory functions.

### For Further Information

For additional information, contact your Cooper Power Systems sales representative.

**TABLE 1**  
**Comparison of Form 3A Accessories with Form 4C control**

Form 3A Control Accessory		Status on Form 4C Control	Form 4C Control Description if Different	Catalog Number
Description	Catalog Number			
Instantaneous Trip	KA1037ME	Standard Feature	High Current Trip	
Instantaneous Lockout	KA1036ME	Standard Feature	High Current Lockout	
Low Current Ground Trip— WE group Reclosers	KA1009ME	Standard Feature		
Low Current Ground Trip— Type VSA Reclosers	KA1012ME	Standard Feature		
Minimum Response Time	KA1163ME	Standard Feature		
Remote Minimum Trip Doubler	KA1002ME	Accessory	Supervisory Alternate Minimum Trip	KME4-77
Locally Operated Minimum Trip Doubler	KA1000ME	Standard Feature	Alternate Minimum Trip Switch	
Reclose Block	KA333ME	Accessory	Block of Close	KME4-66
Sequence Coordination	KA418ME	Standard Feature		
Remote Close	KA316ME	Standard Feature		
Remote Close with Cold Load Pickup	KA2003ME	Standard Feature		
Remote Trip	KA1004ME	Accessory	Supervisory Trip	KME4-77
Remote Trip and Lockout	KA639ME3	Standard Feature		
Control Lockout Remote Indicator	KA472ME3	Accessory		KME4-77
Fault Indicator Targets	KA1137ME1	Standard Feature	Targets	
Fault Indicator Counter-Type	KA1030ME	Standard Feature	Target Counters	
Battery Charging Current Indicator	KA608 ME	Standard Feature		
Thermostatically Controlled Heater	KA542ME10	Standard Feature		
Control Fuse Eliminator for R & W Reclosers	KA531ME10	Standard Feature	Close Retry	
Capacitor Backup Trip for W group Reclosers	KA1119ME	Not Applicable		
Capacitor Backup Trip for VSA, VSAT Reclosers	KA1122ME	Not Applicable		
Manual Trip Tester	KA1007ME	Standard Feature		
Control Cable Locking Sleeve	KA614ME1	Accessory		KME4-56
Fused Convenience Receptacle	KA671ME	Accessory		KME4-57
Spare Trip Resistor Holder	KA814ME	Not Applicable		
24 Vdc Supply Adapter	KA287ME6	Accessory		
48 Vdc Supply Adapter	KA880ME10	Accessory		
125 Vdc Supply Adapter	KA880ME12	Accessory		
Battery Test Voltmeter	KA638ME1	Standard Feature		
Double Size Cabinet	KA695ME	Accessory		
Contact Position Indicator Lights	KA617ME	Standard Feature		
Thermal Amp Demand Metering with instantaneous indicating elements	KA812TR6M6	Standard Feature	Demand Metering	

**TABLE 2**  
**Form 4C Program Settings**

Access Code	Parameter Description
00	Lamp Test
01	Minimum Trip-Phase
01	Minimum Trip-Ground
02	TCC #1-Phase
02	TCC #1-Ground
03	TCC #2-Phase
03	TCC #2-Ground
04	Operations First TCC-Phase
04	Operations First TCC-Ground
05	Operations To Lockout-Phase
05	Operations To Lockout-Ground
06	Reset Time (Seconds)
07	Reclose #1 (Seconds)
08	Reclose #2 (Seconds)
09	Reclose #3 (Seconds)
10	CT Selection
11	Alternate Minimum Trip-Phase
11	Alternate Minimum Trip-Ground
12	Supervisory Close Reset Time (Seconds)
17	Set Target Identifier 1-2
18	Set Target Identifier 3-4
19	Set Target Identifier 5-6
20	Sequence Coordination (On-Off)
21	Target Reset on Success. Recl. (On-Off)
22	Operations Counter (On-Off)
23	Event Recorder (On-Off)
24	Interrupter Duty (On-Off)
25	Ground Trip Precedence (On-Off)
26	Superv. Via Mom. Contact (On-Off)
30	Examine Target
32	Examine Target Counter-Ground
33	Examine Target Counter- 1-2
34	Examine Target Counter- 3-4
35	Examine Target Counter- 5-6
38	Sequence Position
39	Examine Operations Counter
40	Examine Instan. RMS Current-Ground
41	Examine Instan. RMS Current- 1-2
42	Examine Instan. RMS Current- 3-4
43	Examine Instan. RMS Current- 5-6
44	Examine Therm. Demand-Ground
45	Examine Therm. Demand- 1-2
46	Examine Therm. Demand- 3-4
47	Examine Therm. Demand- 5-6
48	Examine Draghand-Max.-Ground
49	Examine Draghand-Max.- 1-2
50	Examine Draghand-Max.- 3-4
51	Examine Draghand-Max.- 5-6
57	Set Integrat. Interval-Phase (Min.)
57	Set Integrat. Interval-Ground (Min.)
65	Accessory Operation Code
66	Malfunction Status Code
70	TCC Group
71	Line Frequency
72	Software Version Number
74	Close Retry Time (Seconds)
76	Control Identification Number
78	Display Board Software Version No.
79	Number of Close-Retry Attempts
80	Data Port (Front Panel) Baud Rate Code (1-300, 2-1200, 3-2400, 4-4800)
81	Comm. Port Baud Rate Code (1-300, 2-1200, 3-2400, 4-4800, 5-9600, 6-19200)
82	Control Communication Address
83	Comm. Port Handshake Mode Code
84	No. of Re-Sync. Time Characters
85	Comm. Port Transmit Enable Delay
90	Security Code for Level 1
91	Security Code for Level 2
92	Security Code for Level 3
99	System Security Entry

Access Code	Parameter Description
	The Following Features Are Accessed With "Select Accy." and "Accy. Scroll" Keys.
100	Complex TCC #1 Setup-Phase (On-Off)
100	Complex TCC #1 Setup-Ground (On-Off)
101	TCC #1 Selection-Phase
101	TCC #1 Selection-Ground
102	TCC #1 Const. Time Adder-Phase (Seconds)
102	TCC #1 Const. Time Adder-Ground (Seconds)
103	TCC #1 Multiplier Value-Phase
103	TCC #1 Multiplier Value-Ground
104	TCC #1 Min. Resp. Time-Phase (Cycles)
104	TCC #1 Min. Resp. Time-Ground (Cycles)
110	Complex TCC#2 Setup-Phase (On-Off)
110	Complex TCC#2 Setup-Ground (On-Off)
111	TCC#2 Selection-Phase
111	TCC#2 Selection-Ground
112	TCC#2 Const. Time Adder-Phase (Seconds)
112	TCC#2 Const. Time Adder-Ground (Seconds)
113	TCC#2 Multiplier Value-Phase
113	TCC#2 Multiplier Value-Ground
114	TCC#2 Min. Resp. Time-Phase (Cycles)
114	TCC#2 Min. Resp. Time-Ground (Cycles)
130	High Current Trip (On-Off)
131	High Current Trip-Gnd. (On-Off)
132	Multiple of Min. Trip-Phase
132	Multiple of Min. Trip-Ground
133	Trip Time Delay-Phase (Cycles)
133	Trip Time Delay-Ground (Cycles)
134	Active Shot Number-Phase
134	Active Shot Number-Ground
140	High Current Lockout (On-Off)
141	High Current Lockout-Gnd. (On-Off)
142	Multiple of Min. Trip-Phase
142	Multiple of Min. Trip-Ground
143	Active Shot Number-Phase
143	Active Shot Number-Ground
153	Set Time Clock-Year
154	Set Time Clock-Month and Day
155	Set Time Clock-Hour and Minute
156	Set Time Clock-Seconds
160	Codes 160 to 169 are associated with the event recorder feature.
161	No. of Events Since Last Reading
162	Event Recorder-Event Number
162	Event Type:
	1-Overcurrent Trip
	2-Reset
	3-Close (Manual Control Sw.)
	4-Close (Supervisory)
	5-Lockout (Manual Control Sw.)
	6-Lockout (Remote)
	7-Lockout (Supervisory)
	8-Trip (Supervisory)
	9-Loss of AC Power
	10-Restoration of AC Power
	11-Sequence Coordination
163	Month and Day
164	Hour and Minute
165	Second
166	Ground Current (X 10 <sup>3</sup> )
167	Phase 1-2 Current (X 10 <sup>3</sup> )
168	Phase 3-4 Current (X 10 <sup>3</sup> )
169	Phase 5-6 Current (X 10 <sup>3</sup> )
170	100% Interrupter Duty (X 10 <sup>3</sup> )
171	Phase 1-2 Interrupter Duty (%)
172	Phase 3-4 Interrupter Duty (%)
173	Phase 5-6 Interrupter Duty (%)
180	Load Profile-Event Number
181	Time-Hour and Minute
182	Ground Current
183	Phase 1-2 Current
184	Phase 3-4 Current
185	Phase 5-6 Current

**TABLE 3**  
Form 4C Timing groups with Time-Current Curves Cross-Referenced to Equivalent Form 3A Curves

Form 4C Timing Group†			Form 3A TCC	
1	2	3	Ground MEA216	Phase MEA217
101	101	101		A
102	102	102	1	
111	111	111	8*	
135	135	135	2	
105	105	105		R
117	117	117		B
133	133	133		C
140	140	140	3	
116	116	116		D
132	132	132		E
104	104	104		N
142			13	
162				K
165			K	
106	106	106	4	
141			11	
131			9	
114			5	
136			6	
119			14	
138	138			W
164				J
118				M
113			8	
161				T
152			7	
163				F
112			15	
107				L
	103		17	
	115			P
	121			G
	122			H
	151		18	
	139		16	
	137			V
	134			Z
	120			Y

† All curves are interchangeable for phase and ground.

**TABLE 4**  
Time-Current Curve Cross Reference Form 3A to Form 4C

F3A TCC	F4C TCC	F3A TCC	F4C TCC
1	102	A	101
2	135	B	117
3	140	C	133
4	106	D	116
5	114	E	132
6	136	F	163
7	152	G	121
8	113	H	122
8*	111	J	164
8†	111	K-Phase	162
9	131	L	107
11	141	M	118
13	142	N	104
14	119	P	115
15	112	R	105
16	139	T	161
17	103	V	137
18	151	W	138
K-Ground	165	Y	120
		Z	134

**Ordering Information Required**

To order a basic Form 4C Type ME microprocessor-based recloser control:

1. Use the chart below to construct a catalog number that describes the required control.
2. From Table 5, specify the catalog number that describes the required control cable.
3. From Tables 6-10, specify the catalog numbers that describe the required control accessories.

**Constructing a Catalog Number**

To order a basic Form 4C control with a 120Vac power supply, battery backup, a 48 Vdc I/O supervisory board, in a stainless steel cabinet; the catalog number should be constructed like this:

**KME4C**

Basic letters for a Form 4C control

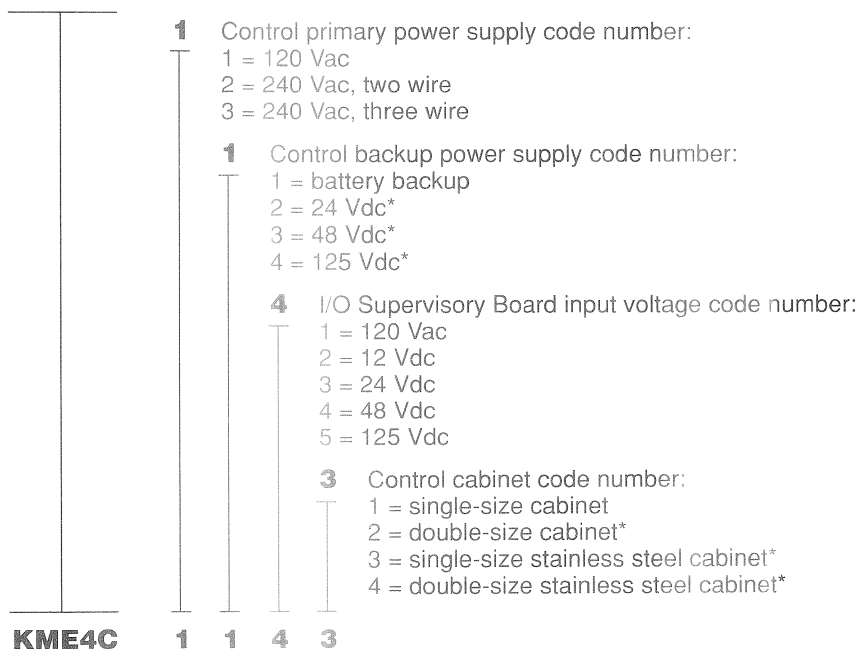

*KME4C1143 is the catalog number for the required control.*

\*Optional accessory priced separately.

**TABLE 5**  
**Control Cable**

Description	Catalog Number
18 gauge conductor control cable, 7-ft. length .....	KA1ME7
16 gauge conductor control cable, 7-ft. length .....	KA18ME7
Longer cable for Types VWE, VWVE27, VWVE38, WE, and WVE	
8 to 80 ft. ....	KA1MEXX*
81 to 125 ft. ....	KA18MEXX*
Longer cable for Types VSA12, VSA16, VSO12, VSO16, VSAT, 35-ft. maximum	
8 to 19 ft. ....	KA1MEXX*
20 to 35 ft. ....	KA18MEXX*

\*Substitute feet for XX in catalog number.

**TABLE 6**  
**Block of Close Accessory**

Description	Catalog Number
Block of close; 120 Vac	
While de-energized .....	KME4-66-1
While energized .....	KME4-66-2

**TABLE 7**  
**Optional Supervisory Operation Accessory; Factory Installed**

Description	Catalog Number
Input/Output accessory board with supervisory features	
Specify input voltage on which control is to operate	
120 Vac .....	KME4-77-1
12 Vdc .....	KME4-77-2
24 Vdc .....	KME4-77-3
48 Vdc .....	KME4-77-4
125 Vdc .....	KME4-77-5

**TABLE 8**  
**Service-Related**

Description	Catalog Number
120 Vac input Receptacle accessory .....	KME4-55*
120 Vac input cable accessory, 15-ft., (For use with KME4-55, KME4-57-1, or KME4-57-3 .....	KME4-67-15
Cable locking sleeve For control cable .....	KME4-56A
For KME4-55 receptacle .....	KME4-56B
120 Vac input connection box with inlet receptacle .....	KME4-57-1
with inlet hole for hard wiring .....	KME4-57-2
with inlet and outlet receptacles .....	KME4-57-3
with inlet and outlet holes for hard wiring .....	KME4-57-4
Cable locking sleeve for 120 Vac connection box .....	KME4-68

\*Requires KME4-67-15 cable.

**TABLE 9**  
**Communication Support Equipment\***

Description	Catalog Number
Form 4C control interface software program .....	KSPS2
Fiber optic communication board and fiber optic-to-RS232 converter .....	KME4-71
Data reader* port-to-computer interface cable, 6 feet .....	KME4-79

\*To order a Data Reader, contact your local Cooper Power Systems Sales Engineer.

**TABLE 10**  
**Training-Related; Equipment Maintenance and Operation Video Cassette Programs**

Description	Catalog Number
Kyle Microprocessor-Based Form 4A Type ME Control Description and Operation video cassette (29 min.) .....	KSPV6 _____
Specify the video cassette _____ format; add format code letter as suffix to catalog number. A = VHS, B = Beta, C = 3/4", D = 1", E = PAL	

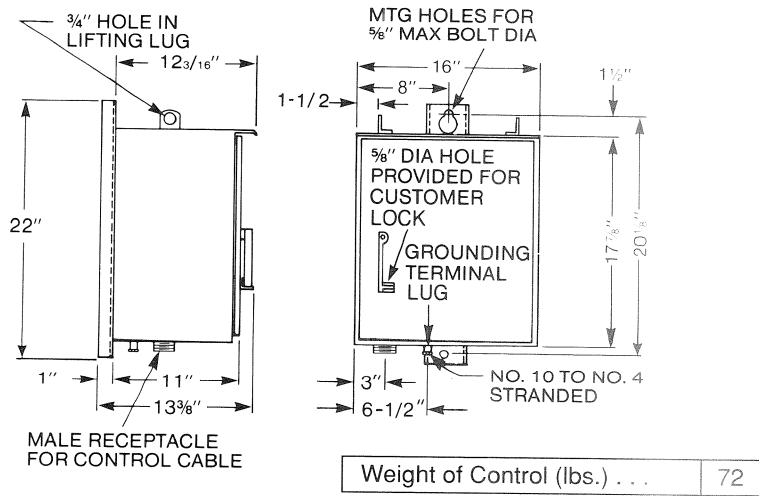

Figure 17  
Form 4C control weight and cabinet mounting dimensions.

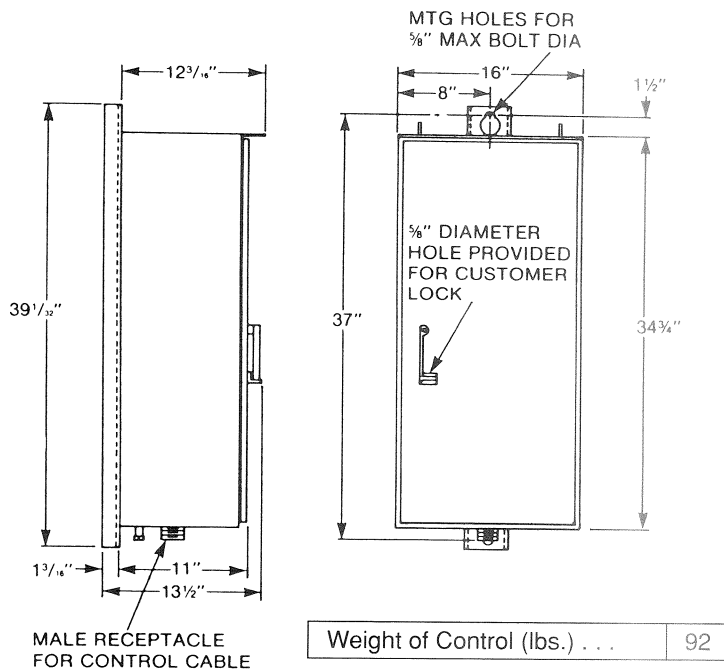

Figure 18  
Mounting dimensions and weight for double size cabinet.

*Microprocessor-based Recloser Control  
for Distribution Switchgear*

© 1990 Cooper Industries, Inc.  
Kyle® is a registered trademark of Cooper Industries, Inc.

**COOPER**

**Cooper Power Systems**

Bulletin 90006 • May 1990 • New Issue  
File: Catalog 280-77

PO Box 2850, Pittsburgh, PA 15230 KTM  
1/93