

Form 4C Microprocessor-Based Recloser Control Operation and Installation Instructions

Service Information
S280-77-1

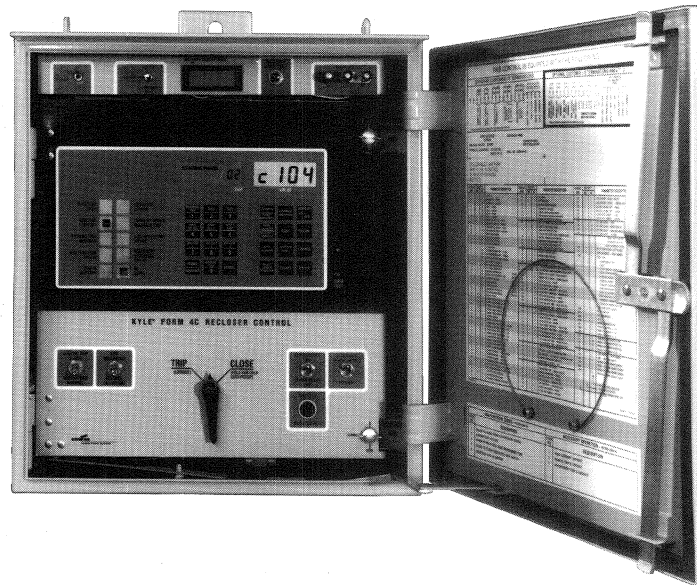

Figure 1.
Kyle® Form 4C Microprocessor-Based Recloser Control.

911064KM-F

Contents

Safety Information	2	Control Security.....	10
Product Information	3	Keyboard Functions	11
Introduction.....	3	Interpreting The LCD Display	12
Acceptance and Initial Inspection.....	3	Installation Procedure	13
Handling and Storage.....	3	Control / Recloser Compatibility	13
Control Battery Storage and Charging	3	Mounting The Control.....	14
Control Power.....	3	Control Cable	14
Initializing The Control.....	3	Grounding The Control.....	14
Description of Control	4	Customer Connection for Ac Power.....	17
Control Operation.....	4	Shielding and Surge Protection of Supervisory Cables	17
Control Front Panel	5	Customer Connection for Remote and Supervisory Operation.....	17
Keyboard and LCD Display	5	Standard Input/Output Board	18
Control Panel LCD Indicators.....	6	Supervisory Input/Output Board Accessory	19
Data Port on Control Front Panel.....	6	Customer Options For Block of Close Feature	20
Manual Operating Controls	7	Before Placing Control and Recloser Into Service	23
Battery Test Panel.....	8	Testing and Troubleshooting	24
Battery Test Procedure	8	Maintenance Information	34
Battery Charger Operation	8	Appendices	35
Back Panel	9		
Initial Programming Prior to Installation.....	10		

SAFETY INFORMATION

Following is important safety information. For safe installation and operation of this equipment, be sure to read and understand all cautions and warnings.

Hazard Statement Definitions

This manual contains two types of hazard statements:

 **WARNING:** Refers to hazards or unsafe practices which could result in severe personal injury, or death, and equipment damage.

 **CAUTION:** Refers to hazards or unsafe practices which could result in damage to equipment or in personal injury.

Safety Instructions

Following are general caution and warning statements that apply to this equipment. Additional statements, related to specific tasks and procedures, are located throughout the manual.

 **WARNING:** Before installing, operating, maintaining, or testing this equipment, carefully read and understand the contents of this manual. Improper operation, handling or maintenance can result in death, severe personal injury, and equipment damage. G101.0

 **WARNING:** This equipment is not intended to protect human life. Follow all locally approved procedures and safety practices when installing or operating this equipment. Failure to comply may result in death, severe personal injury and equipment damage. G102.1

 **WARNING:** Hazardous voltage. Contact with high voltage will cause death or severe personal injury. Follow all locally approved safety procedures when working around high voltage lines and equipment. G103.2

 **WARNING:** This equipment requires routine inspection and maintenance to ensure proper operation. If it is not maintained it may fail to operate properly. Improper operation can cause equipment damage and possible personal injury. G105.1

 **CAUTION:** Equipment misoperation. Do not connect this control to an energized recloser until all control settings have been properly programmed and verified. Refer to the Programming and Operating section of this manual for programming procedures. Failure to comply can result in control and recloser misoperation, equipment damage, and personal injury. G110.2

 **WARNING:** Hazardous voltage. This device is not a substitute for a visible disconnect. Follow all locally approved safety practices. Failure to follow proper safety practices can result in contact with high voltage, which will cause death or severe personal injury. G112.1

Additional Information

These instructions do not claim to cover all details or variations in the equipment, procedures, or process described, nor to provide directions for meeting every possible contingency during installation, operation, or maintenance. When additional information is desired to satisfy a problem not covered sufficiently for the user's purpose, please contact your Cooper Power Systems representative.



PRODUCT INFORMATION

Introduction

Service Information S280-77-1 provides installation and operating instructions for the Kyle Form 4C microprocessor-based recloser control. Before installing and operating this control, carefully read and understand the contents of this manual.

Acceptance and Initial Inspection

Each Form 4C control is completely assembled, tested, and inspected at the factory. It is carefully calibrated, adjusted and in good condition when accepted by the carrier for shipment.

Upon receipt, inspect the carton for signs of damage. Unpack the control and inspect it thoroughly for damage incurred during shipment. If damage is discovered, file a claim with the carrier immediately.

Handling and Storage

Be careful during handling and storage of the control to minimize the possibility of damage. If the control is to be stored for any length of time prior to installation, provide a clean, dry storage area. If storage is in a humid atmosphere, make provisions to keep the control circuitry energized.

NOTE: To energize the control, apply ac power to the ac supply input terminal block located in the lower right hand corner of the back panel of the control cabinet. Refer to the **Customer Connection for Ac Power** section in this manual.

Control Battery Storage and Charging

The 24Vdc control battery is fully charged prior to shipment and is ready for use. The sealed lead acid battery is capable of being stored for at least one year and still maintain sufficient charge to operate the control.

The battery can be kept charged by energizing the control's built-in charger with ac power applied to the customer ac supply input terminal block, located in the lower right hand corner of the back panel of the control cabinet.

If the battery is removed from the control for long term storage, or if spare batteries require charging prior to being put into service, a plug-in, bench-type, 8 amp-hr battery charger is available, identified by the following catalog numbers:

KME4-85-1 (120Vac)

KME4-85-2 (240Vac)

NOTE: If ac power is lost to the control, the battery maintains normal control operations for a minimum of 48 hours. See **Operation Upon Loss Of Ac Power**.

NOTE: When shipped from the factory, the battery is disconnected and its output plug is taped to the cabinet. Connect the battery plug into the mating connector to complete the battery circuit.

IMPORTANT: Connect the control battery when ac power is connected to the control's ac Supply Input Terminal Block, shown in Figure 8. The battery must be disconnected prior to shipping or storing the control.

Control Power

The primary source of power is 120Vac (a 240Vac version of control is also available), which is rectified to charge the power capacitor and to power the dc/dc converter that provides logic voltage to the control. A minimum of 500mA of ac current is required for heater operation, current charging in bulk rate, and to keep all input/output boards energized.

Power to operate the tripping and closing solenoids in the recloser is provided by the power capacitor located near the top of the rear panel of the control. A sealed 24-volt lead acid battery located in the upper portion of the control cabinet (Figure 8) is utilized to provide operating and tripping energy when ac power is temporarily lost. The control is equipped with an ac-powered, temperature-regulated battery charger.

Operation Upon Loss Of ac Power

If the control is equipped with the standard 24Vdc lead-acid battery (instead of the optional provisions for connection to a substation battery supply), the control will maintain full operation from the battery power supply for a minimum of 48 hours at 20°C (24 hours at -40°C). To prevent battery damage, the control will shut down automatically upon detection of low battery voltage below 22.7 Vdc.

Control programming settings and parameters—including event recorder, duty monitor, and demand metering data—are stored in non-volatile memory. All data is retained in the event that both ac power and battery backup power are disconnected.

The control is equipped with a power status indicator contact for remote indication of a loss of ac power or backup power supply (see the **STANDARD SUPERVISORY INPUT/OUTPUT BOARD** section of this manual).

Local indication for loss of ac power is provided by the ac Supply LCD (Figure 5) indicator on the front panel of the control. If low battery voltage is detected, the Malfunction LCD and Check Battery LCD indicators will be activated to provide local indication of low battery voltage.

Initializing the Control

Ac power is required to initialize or re-initialize the control each time it has been de-energized. The control clock should be reset upon re-energization. Refer to *Service Information S280-77-4 Form 4C Microprocessor-Based Recloser Control Programming Guide* for the procedure **SETTING THE CONTROL CLOCK**.

DESCRIPTION OF CONTROL

Control Operation

Line current flowing through the recloser is sensed by three internally mounted bushing-current transformers in the recloser, one for each phase. When the phase current or the zero-sequence (ground) current exceeds its programmed minimum-trip value, the Kyle Form 4C control initiates the programmed sequence of recloser-tripping and reclosing operations. If the fault is temporary, the control ceases to command recloser operations after the successful reclosure, and the control resets to the start of its operating sequence after a preset time delay. If the fault is permanent, the control performs its complete programmed sequence of recloser commands and locks out with the recloser open. Once locked-out, the control must be reset to the start of its operating sequence, which closes the recloser.

A functional block diagram of the Form 4C control operation is shown in Figure 2. Line current conditions are monitored continuously by three bushing-type current transformers in the recloser, one for each phase. Output of these transformers is fed to the control front end which consists of isolation transformers and a 4:1 multiplexer. The control's microprocessor samples the current and computes the RMS current for each phase and ground.

When current above the programmed minimum-trip level is detected in one or more phases, the following chain of events will occur for an operating sequence of two fast and two delayed operations:

1. The overcurrent signal is integrated with time on the selected curve for the first trip operation to produce the signal which energizes the trip circuit.

2. Energizing the trip circuit connects the battery and capacitor to the trip solenoid to open the recloser.
3. Simultaneously, the microprocessor starts timing on the first reclosing interval-delay time.
4. Upon expiration of this reclosing interval-delay, a closing signal is issued from the control, closing the recloser and selecting the time-current characteristics for the second trip operation.

If current remains above the minimum-trip level, the tripping and reclosing sequence (fast and delayed operation) is repeated as programmed to lockout.

If the overcurrent is cleared before the operating sequence reaches lockout, the microprocessor starts timing a reset-delay when the recloser closes into the line and current is below minimum trip.

5. When the reset-delay times out, the control is reset to the home state and is ready for another programmed operating sequence. If current rises above minimum trip prior to the reset-delay timing-out, the timer is halted and the control continues the operating sequence from where it left off and the accumulated reset-delay timing is cleared.

Ground fault tripping is separately programmable and includes minimum trip, operations to lockout, and number of operations on fast and delayed curves. Reclose and reset intervals are common for phase and ground fault operation.

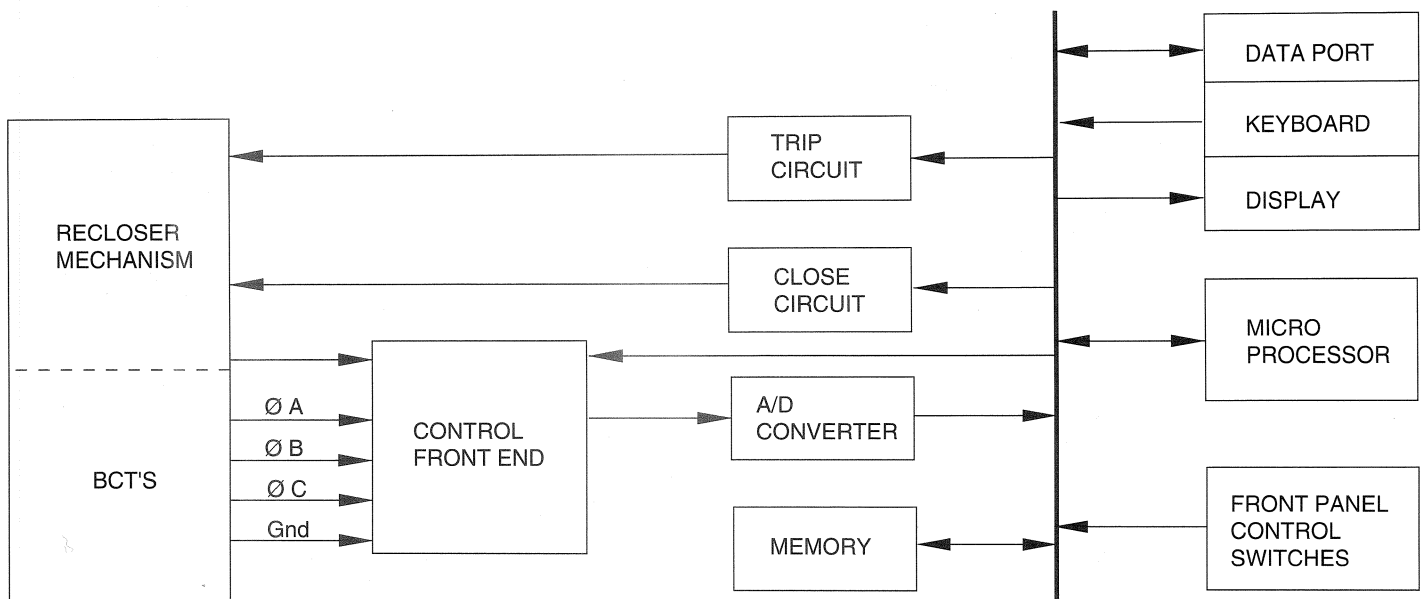

Figure 2.
Functional block diagram of Form 4C Control.

Control Front Panel

The battery meter and test panel is located at the top of the front panel of the control. The swing-out front panel contains the keyboard, LCD displays, LCD indicators, and manual operation switches of the control (Figure 3).

Manual operation and control switches are located in the lower, light gray portion of the front panel. Programming and display elements are located in the upper, dark gray portion of the front panel.

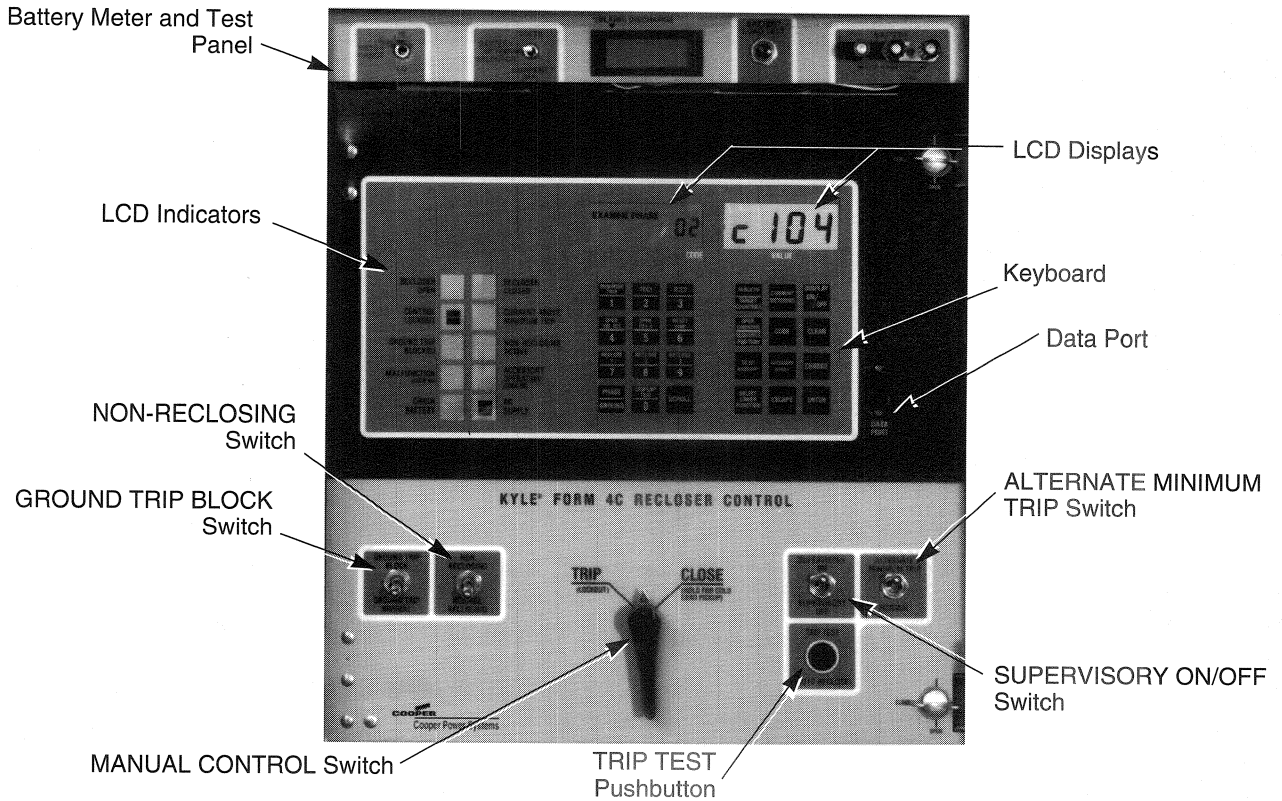

Figure 3.
Form 4C control front panel.

911064KM-F

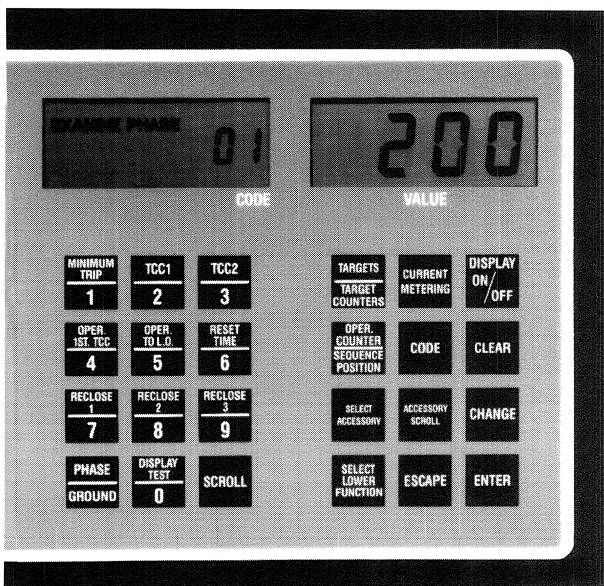

Figure 4.
Form 4C control keyboard and LCD displays.

901022KMA-F

Keyboard and LCD Display

The Form 4C control keyboard has 24 keys and a large visible LCD display, shown in Figure 4. It is activated by pressing the DISPLAY ON/OFF key. The display will remain on until the key is pressed again, or will shut off automatically ten minutes after the last keyboard entry is made.

The dual-pad keyboard has dedicated function keys to simplify operator interrogation of the most common control parameters and functions. The functions of all keys are defined in Figure 9.

Control Panel LCD Indicators

Ten LCD indicators (Figure 5), located to the left of the keyboard and display, provide status information on control and recloser functions. The operation of each LCD is described as follows:

RECLOSER OPEN indicates that the recloser contacts are in the open position.

RECLOSER CLOSED indicates that the recloser contacts are in the closed position.

CONTROL LOCKOUT indicates that the control has tripped to lockout (no further automatic reclosing) sequence.

CURRENT ABOVE MINIMUM TRIP indicates that line current is above the programmed minimum trip value.

GROUND TRIP BLOCKED indicates whether or not ground trip block has been activated by either the front panel switch or via supervisory control.

NON-RECLOSING ACTIVE indicates whether or not non-reclosing has been activated either by the front panel switch or via supervisory control.

MALFUNCTION indicates when one or more of the five following malfunctions is detected:

- Failure to close from a supervisory signal.
- Low/High battery voltage (resets automatically upon restoration of normal battery voltage).
- Power down in less than 48 hours.
- Failure to close from the manual control switch.
- Internal diagnostics alarm.

Keyboard interrogation of Access Code 66 will display a malfunction code. Malfunction codes are listed on the label inside the cabinet door. To clear the Malfunction LCD display, press the CLEAR key while Code 66 is displayed.

ACCESSORY OPERATION identifies special accessory operations, where identification will aid in troubleshooting. Access Code 65 will display the code identifying the accessory:

- High-Current Lockout (Code 1)
- Remote Trip and Lockout (Code 2)
- Supervisory Trip and Lockout (Code 3)

A complete list of access codes, definitions, and parameters is located in *Service Information S280-77-4 Form 4C Microprocessor-Based Recloser Control Programming Guide*.

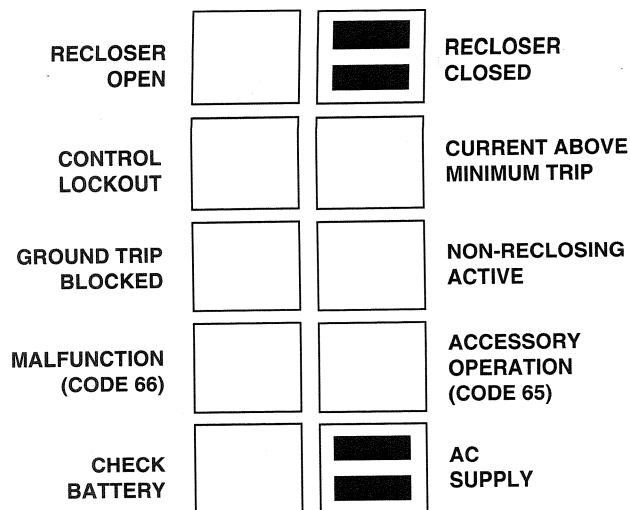

Figure 5.
Control panel LCD indicators.

CHECK BATTERY indicates that the battery voltage is low (below 23.3 volts). The control's power status indicator contact will also operate to provide remote indication of low battery voltage.

AC SUPPLY indicates the presence of ac power which is required for normal control operation.

Data Port on Control Front Panel

The Form 4C control is equipped with a data port located on the control front panel. It is used for temporary connection of a Data Reader or personal computer to the control. The data port permits the operator or technician to download all the programming information stored in the control, including operating parameters, event recorder, duty monitor, demand metering, and load profile monitor data.

The data port also provides a convenient means to upload control parameters compared to manual keyboard entry procedures at the control keyboard.

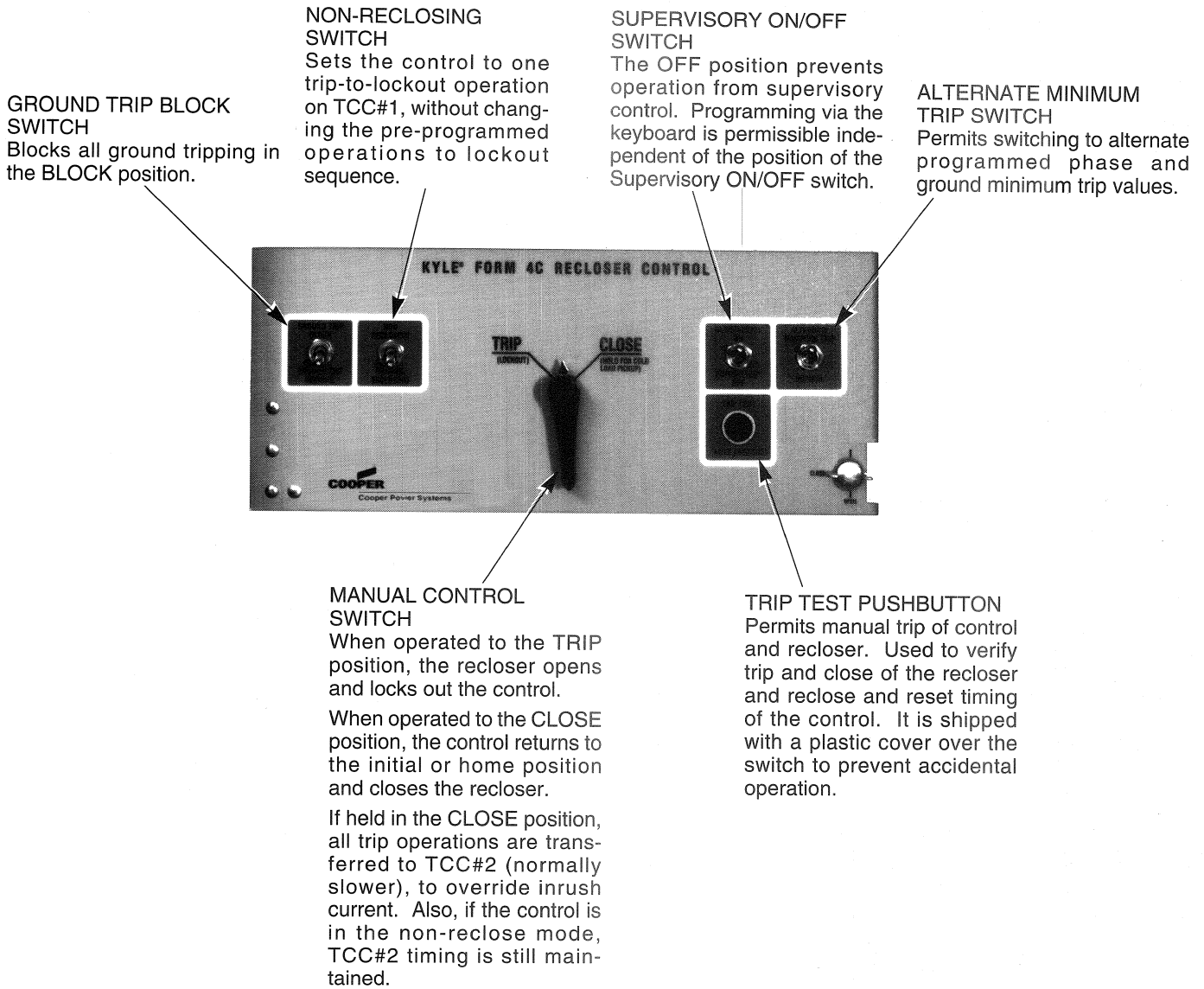

Figure 6. Manual operating controls on the lower portion of the Form 4C control front panel.

911064KM-F

Manual Operating Controls

The lower portion of the front panel of the Form 4C control contains manual operating controls as described in Figure 6.

Trip-Test Pushbutton

The Trip-Test pushbutton is used to test-trip the recloser. Do not use this button during normal control operation. When shipped from the factory, the pushbutton is covered with a protective plastic cap to prevent accidental operation. If the Trip-Test Pushbutton is pressed, the attached recloser will immediately trip and reclose according to the control's programmed sequence of operations.

IMPORTANT: Premature Tripping. Do not press the Trip-Test pushbutton without connection to a recloser. If the the Trip-Test pushbutton is pressed without connection to a recloser, the control stores the trip-test command. When the control is later connected to a recloser on a distribution power line, the control trips the recloser and service is interrupted.

The recloser must be properly bypassed before operating the Trip-Test pushbutton. If the Trip-Test pushbutton is operated without bypassing the recloser, the recloser trips and service is interrupted.

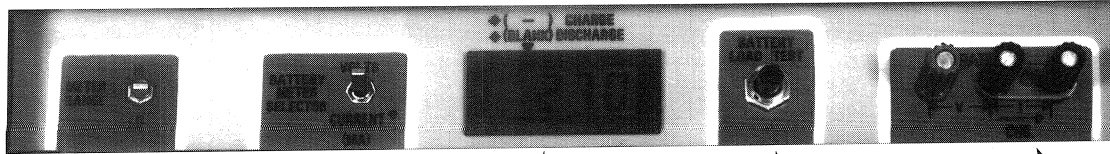

METER RANGE SWITCH

Set meter range switch to HI or LO range to read battery voltage or charge/discharge current.

BATTERY METER SELECTOR SWITCH

When spring-centered selector switch is pushed up, battery voltage is displayed. When pushed down, battery charge/discharge current is displayed.

METER DISPLAY

Displays battery voltage or charge/discharge current.

BATTERY LOAD TEST SWITCH

When operated, it places a resistor across the battery circuit to provide battery load. Voltage can be read either through LCD display or voltmeter connected to battery test terminals.

BATTERY TEST TERMINALS

Provide easy access for testing battery voltage and charging rate. To test with external meter: Open shorting link only to read charge/discharge current, connect test leads and press Battery Meter Selector switch to down position.

Figure 7.
Battery test panel controls and meter display.

88929KMA-F

Battery Meter and Test Panel

Located at the top of the front panel of the control is the battery test panel (Figure 7). The battery meter and test panel contains switches, meter display and test points for checking the condition of the control's 24 Vdc lead acid battery.

CAUTION: Equipment damage. Shorting battery positive to battery negative at the battery test terminals on the control panel will cause damage to the control. The control will be inoperative and possible misoperation (unintentional operation of the recloser) may result.

T214.0

Battery Test Procedure

With Control Connected to Ac Power

Use the following procedure to test the performance of the control battery while connected to ac power.

Initial Condition: Ac power is connected to control, battery circuit connected, and METER RANGE Switch set to LO.

1. Press the BATTERY METER SELECTOR switch to Volts position for 5 seconds. Battery voltage should read 27-29 Vdc.
2. With the BATTERY METER SELECTOR switch depressed, press the BATTERY LOAD TEST switch for 5 seconds (places 5 ohm load on battery). Voltage drop should not exceed 3.0 Vdc.

Without Control Connected to ac Power

The control battery can also be tested if the ac power is disconnected and the control is operating on battery power only.

Initial Condition: Ac power is disconnected, battery circuit connected, and METER RANGE Switch set to LO.

1. Press BATTERY METER SELECTOR switch to Volts position for 5 seconds. Battery voltage should read 25-27 Vdc. If the battery voltage is less than 23.3 Vdc,

recharge the battery prior to performing the battery load test described in step 2.

2. With the BATTERY METER SELECTOR switch depressed, press the BATTERY LOAD TEST switch for 5 seconds (places 5 ohm load on battery). Voltage drop should not exceed 3.0 Vdc.

Battery Charger Operation

The Form 4C control battery charger is divided into two parts; a trickle charger (5-19 mA) that is always on, and a voltage-dependent charger that supplies battery charge current up to 450 mA.

The total charge current depends on what part of the cycle the charger is in. The first time through the cycle the charger will operate in the following sequence:

1. When battery voltage is below approximately 20.8 Vdc only the trickle charger is enabled.
2. When battery voltage rises above 20.8 Vdc the charger will go into its bulk rate charge mode. The charge current will initially be up to a maximum of 450 mA. The charge current will decrease gradually until the battery reaches 28.4 Vdc.
3. When battery voltage reaches 28.4 Vdc, the charger reverts to the trickle charge rate. If the voltage falls below the float voltage, which is 27.6 Vdc at 25°C, the charger will supply anywhere from the trickle charge current up to 450mA until the battery is fully charged.
4. In a normal steady-state mode, when the battery is fully charged (27 to 29 Vdc), there will only be a trickle charge (approximately 6-10 mA) supplied to the battery.

Control Back Panel

The control battery, cabinet heater, power supply, standard supervisory input/output board, supervisory input/output board accessory, and the digital communica-

tions board accessory are located inside the control cabinet on the back panel of the control as shown in Figure 8.

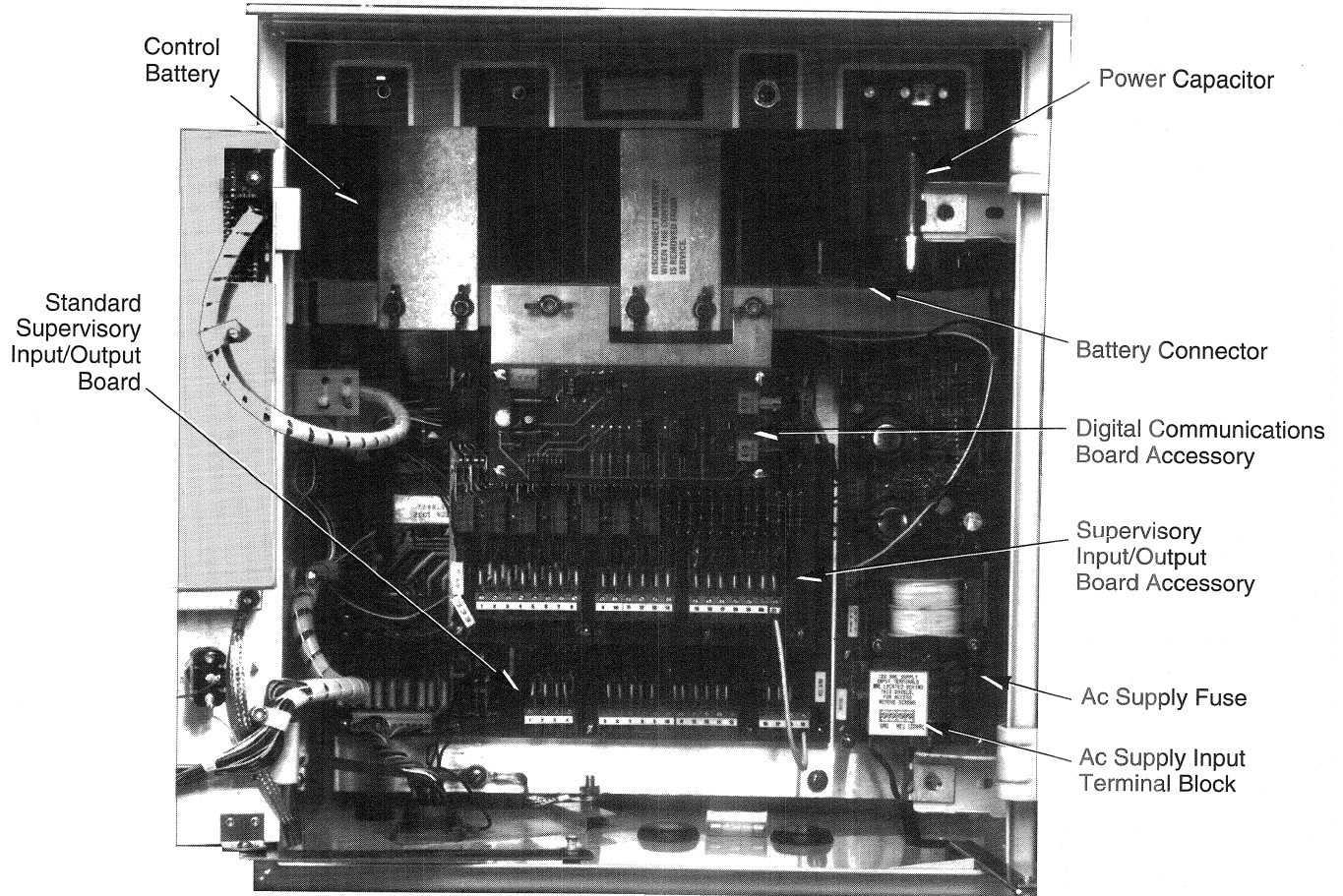



Figure 8.
Inside back panel of Form 4C control.

901023KMA-F

Initial Programming Prior to Installation

The control must be programmed with all necessary operating settings and parameters prior to operation with an energized recloser.

 **CAUTION:** Equipment misoperation. Do not connect this control to an energized recloser until all control settings have been properly programmed and verified. Refer to *Service Information S280-77-4 Form 4C Microprocessor-Based Recloser Control Programming Guide* for programming procedures. Failure to comply can result in control and recloser misoperation, equipment damage and per-

Initial programming of the Form 4C control is the responsibility of a qualified technician or engineer who is familiar with the functions of the control and the programming parameters required for the specific recloser installation. The control can be programmed from the keyboard, data port, or a digital communications accessory

Service Information S280-77-4 Form 4C Microprocessor-Based Recloser Control Programming Guide lists all access codes, program settings, and detailed operating descriptions of the code parameters. All control program settings, parameter descriptions, and programming access codes are also listed on the control information label located inside the cabinet door.

Control Security

The Form 4C control has a security system which limits access to only those control functions appropriate to the operator's responsibilities, and requires the keyboard entry of a four-digit security code. It prohibits unauthorized access to programming and operating parameters. Interrogation of the control to display operating parameters and read-only functions of the control does not require entering a security code.

Service Information S280-77-4 Programming Guide lists all control program settings along with their keyboard access codes, and the security level required to make programming changes.

Keyboard Functions

Prior to interrogation and programming, the operator should be familiar with the control's keyboard. Figure 9 shows each key and its description of operation.

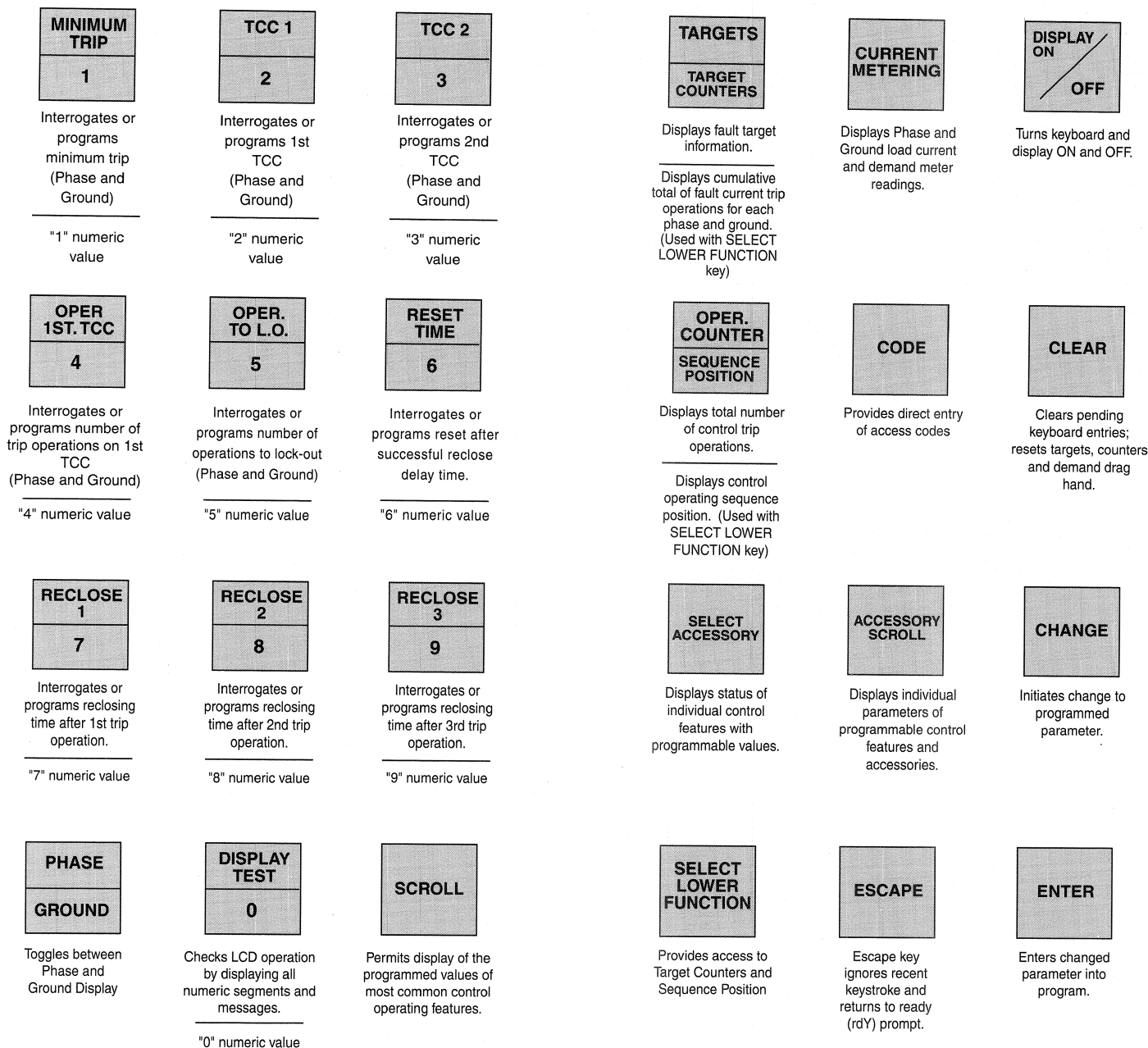

Figure 9.
Keyboard functions.

Interpreting the LCD Displays

During interrogation and programming, the LCD displays provide a readout of all keyboard operations (Figure 10). The left display shows the program access code entered and indicates whether the control is in the **EXAMINE**, **SCROLL**, or **CHANGE** mode. **PHASE** or **GROUND** will appear if the parameter has a phase or ground value. The right display will show a parameter value up to four digits.

EXAMINE indicates that the displayed access code is being interrogated.

SCROLL indicates the SCROLL key can be used to obtain additional information.

CHANGE indicates the displayed access code is being changed.

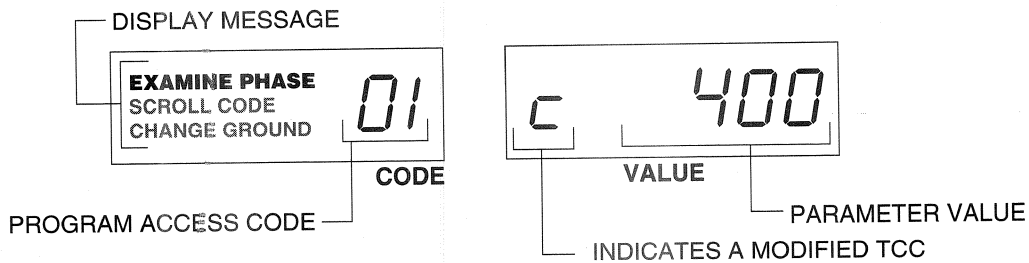

Figure 10.
Interpreting the LCD display.



INSTALLATION PROCEDURE

Control / Recloser Compatibility

Reclosers manufactured prior to June 1989 are equipped with Type A bushing current transformers. These reclosers were designed for use with Form 2, Form 3, and Form 3A controls. Because the Form 4C control is designed for use with reclosers equipped with Type B current-sensing Transformers, reclosers retrofitted with Form 4C controls must also be retrofitted with Type B current transformers. All reclosers manufactured since 1989 are equipped with Type B (1000:1, 1000/500:1, or 2000:1) sensing CT's.

Reclosers equipped with Type B sensing CT's are compatible with all Kyle recloser controls (Form 2, Form 3, Form 3A, Form 4A and Form 4C controls), and are identified with the following label prominently displayed on the recloser sleet hood or the front of the operator cabinet:

NOTICE

RECLOSER IS EQUIPPED WITH TYPE B SENSING CT'S.
RECLOSER DOES NOT HAVE A BATTERY CHARGER.

The Form 4C control can be used with the old-style Type A CT's; however, the event recorder and duty cycle monitor will have limited accuracy for currents above 5000 amps.

Retrofit kits with the new Type B sensing CT's are available to upgrade existing families of reclosers for operation with Form 4C controls. For additional information, contact your Cooper Power Systems representative.

For identification, Table 1 lists the serial number breaks between old-style Type A and the new-style Type B sensing CT's. Below this serial number, the recloser is equipped with the Type A CT's.

NOTE: For reclosers shipped prior to June 1989 and not listed below, please contact your Cooper Power Systems representative with the recloser type and serial number for verification of type A or B bushing current transformers.

TABLE 1
Serial Number Break for Reclosers with Type A Sensing CT's

Recloser	Below Serial Number
RXE	5831
RVE	5894
WE	11199
WVE	3695
VWE	7199
VWVE27	7208
VWVE38	1204

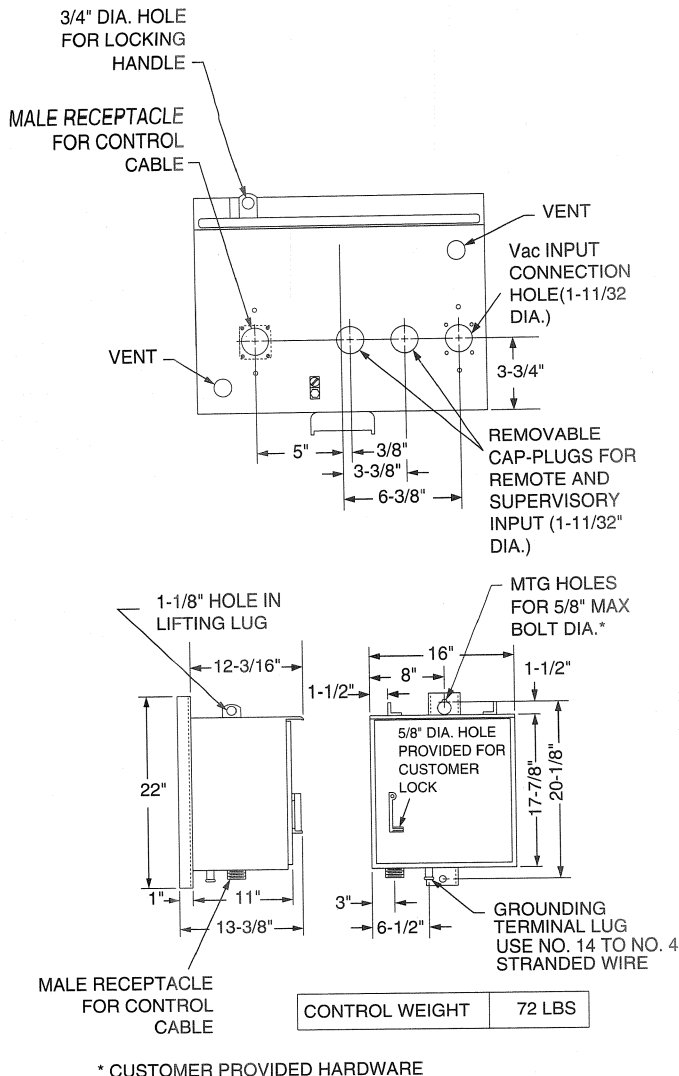

Figure 11.
Cabinet mounting dimensions.

Mounting The Control

The Form 4C recloser control should be mounted at a convenient, accessible location.

- For pole-mounted installation, a hole and keyway in the control mounting bracket accommodates a 5/8" bolt.
- For substation installation, brackets are available as an accessory for mounting the control to a substation frame.

Limits on control cable length are determined by the maximum distance between the control and recloser: Solenoid-operated and motor-operated reclosers have different maximum distances.

- Up to 125* feet for solenoid-operated reclosers (VWE, VWVE27, VWVE38X, WE, WVE27, WVE38X).
- Up to 35* feet for motor-operated reclosers (VSA12, VSA12B, VSA16, VSA20, VSA20A, VSO12, VSO16).

* Consult your Cooper Power Systems representative if longer cable lengths are required.

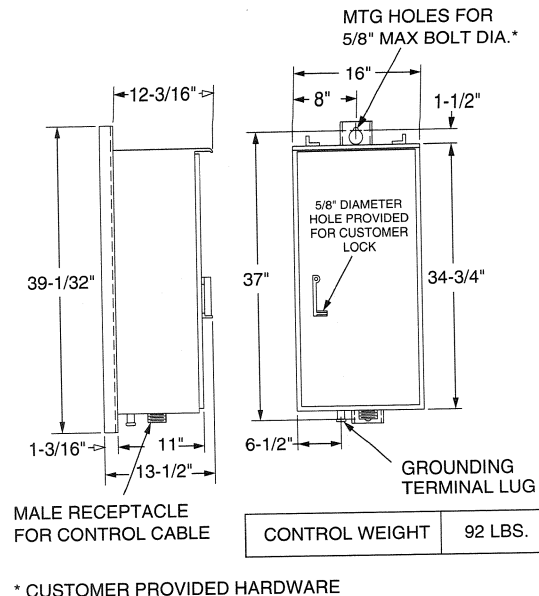

Figure 12.
Double-size cabinet mounting dimensions.

Outline, mounting, and knockout dimensions are shown in Figure 11 for the control cabinet. Figure 12 shows mounting dimensions for a double-size control cabinet.

Control Cable

The control cable is fabricated with connectors which mate with the female receptacle of the recloser on one end, and the male receptacle of the control on the other end.

NOTE: The control cable must be supported along its length to prevent repeated movement due to wind or other outside forces which can damage the cable.

Grounding The Control

The control cabinet must be grounded. A grounding connector on the underside of the cabinet will accommodate No. 14 solid through No. 4 stranded conductors. Suggested methods for grounding the control and recloser are shown in Figures 13 and 14.

It is important for effective surge protection that all control and power conductors for the Form 4C be routed parallel to a corresponding ground path. For example, the ac power supply for the control should be parallel to and equal in length to the transformer ground path. The control cable should be parallel to and routed close to the recloser ground path.

IMPORTANT: All external inputs to the Form 4C control must be routed within 8 inches of their corresponding ground. During a surge, a potential of approximately 1.5kV per foot can develop in the conductors. Differences between conductor and ground path lengths can add additional stress to the control components in the event of a power surge.

Installation of the control must include the following:

- Protection of the recloser bushings and the supplying transformer with lightning arrestors.
- Grounding of the recloser head.
- Grounding of the transformer tank.
- Grounding of the control cabinet.

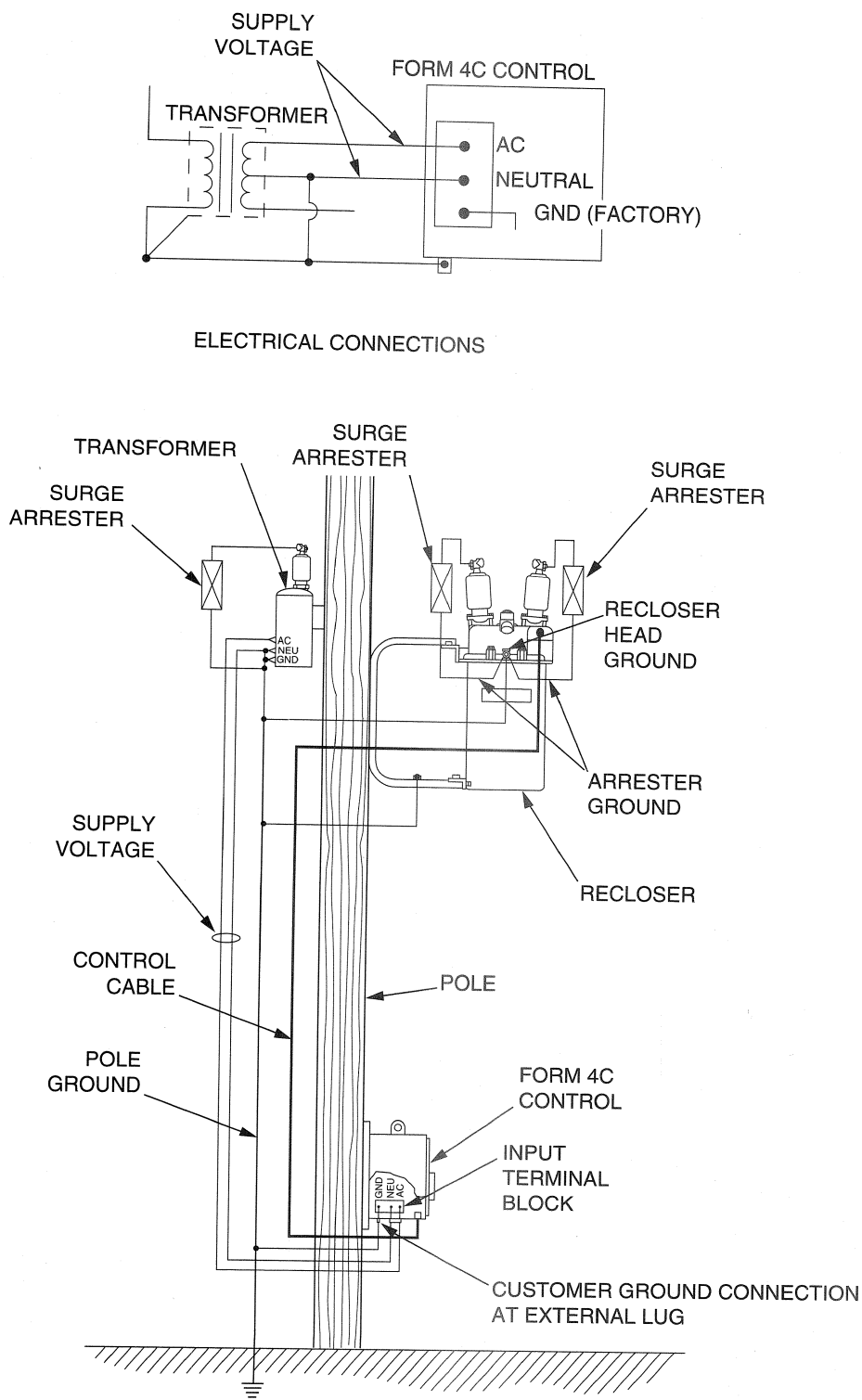

Figure 13. Recommended grounding method for Form 4C Control with local supply voltage transformer.

Installation of the control must include the following:

- Protection of the recloser bushings and the supplying transformer with lightning arrestors.
- Grounding of the recloser head.
- Grounding of the transformer tank.
- Grounding of the control cabinet.

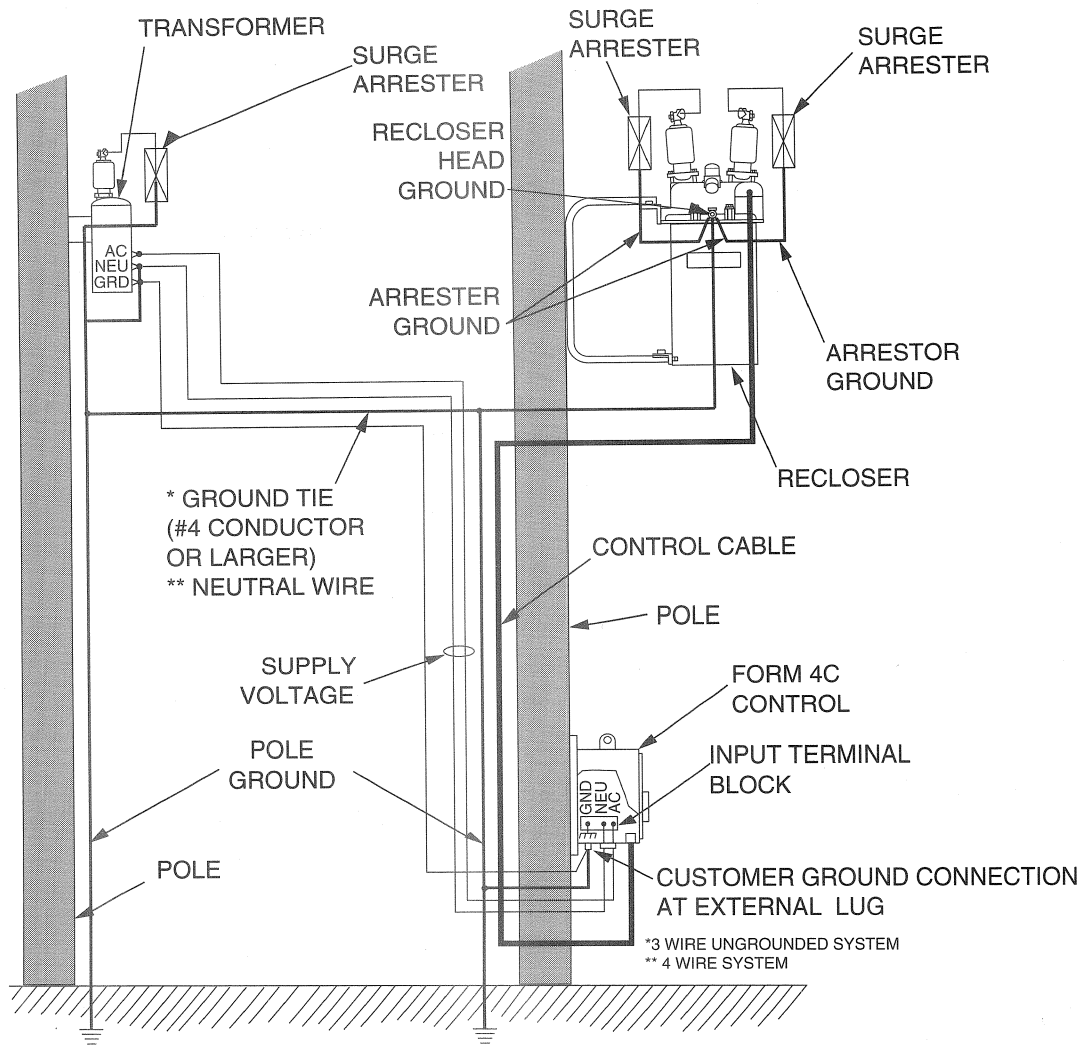
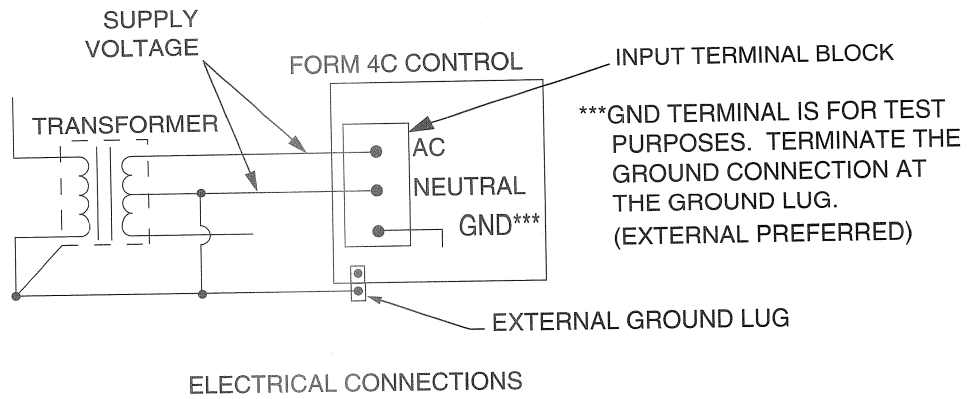

Figure 14. Recommended grounding method for Form 4C Control with remote supply voltage transformer.



Customer Connections for Ac Power

All Form 4C controls require customer-supplied ac power for operation. The maximum operating current requirement for the control is approximately .0.7 amps. The customer's ac power supply cable is routed through the knockout entrance located on the bottom of the control cabinet. A weathertight connector is mounted in the knockout hole and connected to the ac input terminal strip located behind the plastic cover shield in the lower right-hand corner of the back panel of the control cabinet (Figure 16). The input power supply consists of an ac and neutral connection; while the terminal strip ground is for bench testing purposes only. Ground the control cabinet to the pole through the external cabinet ground lug (Figure 11).

NOTE: It is not necessary to use shielded cable if the ac supply path is running next to the transformer ground path.

Shielding and Surge Protection of Supervisory Cables

All supervisory operation and control monitor leads should be protected within shielded cables. The input voltage COMMON wire must be grounded at the source and connected to the Supervisory Input/Output Terminal Block at Terminal 18 or 19. A single common wire can be used for multiple inputs if it is jumpered at the I/O board terminals. The cable shield must be grounded at the Form 4C control only, see Figure 17.

All remote operation and monitor leads must be protected with metal oxide varistors (MOV's) 320Vac, 160 Joules, or equivalent (Figure 17).

 **CAUTION:** Equipment damage. Do not drill connection holes into the top of the cabinet. Connection holes in the top of the cabinet will allow moisture to seep into the control and damage the components or cause control misoperation. Failure to comply will void the control's factory warranty.

Customer Connections for Remote and Supervisory Operation

Figure 16 shows customer connections for the 19-position standard supervisory input/output terminal block and for the 21-position supervisory accessory input/output block. The terminal block connectors will accommodate conductor leads up to 12 AWG maximum.

STANDARD SUPERVISORY INPUT/OUTPUT BOARD

The Form 4C control includes a standard input/output board for supervisory and remote operation and indication.

The supervisory I/O board requires customer provided power of 120Vac, 12Vdc, 24Vdc, 48Vdc, or 125Vdc for control operation. The SUPERVISORY ON/OFF switch permits supervisory operation of the control. With the supervisory switch in the ON position, the supervisory close and the supervisory trip and lockout functions are operative. With the supervisory switch in the OFF position, supervisory operation is blocked. The control can be tripped or closed via the manual control switch, regardless of the position of the supervisory switch.

The supervisory switch can be in the ON or OFF position when making programming changes from the keyboard.

Customer connections to the standard supervisory input/output board are made to a 19 position terminal strip shown in Figures 16 and 17.

Block Of Close

The Block of Close feature permits control of the closing operations of the recloser. The feature is used for supervisory functionality, supervisory dispersed generation applications, or disabling closing functions for live-line work. The control will not reset while Block of Close is enabled, since reset timing begins only after reclosing, and then only if no fault current is present.

This feature is factory-installed but is only enabled at customer request. The Block of Close feature can be enabled with or without 120 Vac energizing the Block of Close relay (Figure 15); however, it requires 120Vac for operation and is independent of the customer-provided power used with the standard supervisory input/output board.

Remote Trip and Lockout

Remote Trip and Lockout trips the recloser open and locks out the control. It functions independently of the position of the SUPERVISORY ON/OFF switch. It can be used for tripping from external relays and alarms.

A minimum signal duration of 0.25 seconds is required. The signal can also be continuously maintained to prevent closing.

Supervisory Switch Status Indicator

Supervisory Switch Status provides a closed contact when the SUPERVISORY ON/OFF switch is in the ON position.

Power Status Indicator

Power Status Indicator provides a dry contact to provide remote status indication when either of the following conditions exist:

1. Low ac input (below 90Vac).
2. Low battery voltage (below 23.3Vdc or above 32.4Vdc).

Recloser Status Indicator

Recloser Status Indicator provides a dry contact that operates to indicate open or closed status of the recloser contacts.

Malfunction Indicator

Malfunction Indicator provides a dry contact to provide remote status indication when one of the following five malfunctions are detected:

1. Failure to close from a supervisory signal.
2. Low/High battery voltage.
3. Power down in less than programmed time.
4. Failure to close from the manual control switch.
5. Internal diagnostics alarm.

Supervisory Trip and Lockout

Supervisory Trip and Lockout trips the recloser open and locks out the control. The control remains locked out until it is closed manually or by the supervisory close feature. A minimum signal of 0.25 seconds duration is required.

Supervisory Close

Supervisory Close initiates a closing signal to the recloser and modifies the operating sequence to one trip to lockout on TCC2 for a selected time interval (Access Code 12). After the adjustable reset time interval has elapsed, the control returns to its programmed sequence of operations. A momentary signal (minimum of 0.25 seconds duration) is required for proper operation.



SUPERVISORY INPUT/OUTPUT BOARD ACCESSORY

The Supervisory I/O Board Accessory is available for the Form 4C control to extend its supervisory operation capabilities. The accessory I/O board includes contacts to provide supervisory control and status indication of four additional control and recloser functions, along with targets.

The supervisory control functions require customer-provided power of 120Vac, 12Vdc, 24Vdc, 48Vdc or 125Vdc for operation and are controlled by the SUPERVISORY ON/OFF switch.

Customer connections to the Supervisory Input/Output Board accessory are made to the 21 position terminal strip shown in Figures 16 and 17.

The accessory I/O board includes:

Ground Trip Block Status Indicator

The Ground Trip Block Status indicator provides a closed, dry contact to provide remote indication when the control is placed into the ground trip block mode from either the front panel GROUND TRIP BLOCK switch or through supervisory control.

Non-Reclosing Status Indicator

The Non-Reclosing Status indicator provides a closed, dry contact to provide remote indication when the control is placed into the non-reclosing mode from either the front panel NON-RECLOSING switch or through supervisory control.

Alternate Minimum Trip Status Indicator

Alternate Minimum Trip Status indicator provides a closed, dry contact to provide remote indication when the control is placed into the alternate minimum trip mode from either the front panel ALTERNATE MINIMUM TRIP switch or through supervisory control.

Control Lockout Status Indicator

The Control Lockout Status indicator provides a closed, dry contact to provide remote indication of control lockout.

Remote Fault Target Indicator

Remote Fault Target Indicator provides separate dry contacts for remote indication of phase targets for bushings 1-2, 3-4 and 5-6. If the Sensitive Ground/Earth Fault is ON, the contacts will indicate for phase, ground and sensitive ground faults.

Supervisory Ground Trip Block

Supervisory Ground Trip Block provides supervisory operation of ground trip block by a remote momentary or maintained signal. Supervisory operation is dependent upon the positions of the front panel GROUND TRIP BLOCK and SUPERVISORY ON/OFF switches. See Appendix IV for additional information. Momentary (0.25 seconds minimum) or maintained signal mode is programmable using Access Code 26.

Supervisory Non-Reclosing

Supervisory Non-Reclosing provides supervisory non-reclosing input by a remote momentary or maintained signal. Supervisory operation is dependent upon front panel NON-RECLOSING and SUPERVISORY ON/OFF switch positions. See Appendix III for additional information. Momentary (0.25 seconds minimum) or maintained signal mode is programmable using Access Code 26.

Supervisory Alternate Minimum Trip

Supervisory Alternate Minimum Trip provides selection of alternate programmed values for phase and ground minimum trip. This feature is actuated by a remote momentary or maintained signal. Supervisory operation is dependent upon front panel ALTERNATE MINIMUM TRIP and SUPERVISORY ON/OFF switch positions. See Appendix II for additional information. Momentary (0.25 seconds minimum) or maintained signal mode is programmable using Access Code 26.

Supervisory Trip

Supervisory Trip provides the ability to trip the recloser from a remote signal. Normal reclosing operations will follow. Operation is permitted only when the SUPERVISORY ON/OFF switch is ON. A momentary signal (minimum of 0.25 seconds) is required for proper operation.

CUSTOMER OPTIONS FOR THE BLOCK OF CLOSE FEATURE

The Block of Close feature is installed in the Form 4C control and is enabled at the factory or in the field, at the customer's request. The Block of Close feature can be selected with or without 120 Vac energizing the Block of Close relay (Figure 15); but it requires 120Vac for operation and is independent of the customer-provided power used with the standard supervisory input/output board.

Activating Block of Close While Relay is De-Energized

If the control is in the Block of Close While De-energized mode (identified on the control information label inside the cabinet door), a 120Vac power source must be connected to the feature's voltage input terminals in order for the recloser to close. Refer to Figure 16 (Detail B), Figure 17 and the appropriate 120Vac power signal to the Block of Close Terminals 1 and 2, on the standard I/O board terminal block. Figure 15 shows the wiring for the Block of Close accessory from the Block of Close terminals on the Standard I/O Board to the ac Supply Input Terminal Block.

To activate the Block of Close while the relay is de-energized, refer to Figure 15 and follow the procedure below:

1. Locate factory-installed, Block of Close jumpers J1-C, B, A and J2-B, A. See Figure 15 for location of jumpers.
2. Cut jumper J1-C in two places, leaving a minimum of 0.125 inch gap.
3. Cut jumper J1-A in two places, leaving a minimum of 0.125 inch gap.
4. Cut jumper J2-A in two places, leaving a minimum of 0.125 inch gap.

Activating Block of Close While Relay is Energized

To activate the Block of Close while the relay is energized, follow the procedure below:

1. Locate factory-installed, Block of Close jumpers J1-C, B, A and J2-B, A. See Figure 15 for location of jumpers.
2. Cut jumper J1-C in two places, leaving a minimum of 0.125 inch gap.
3. Cut jumper J1-B in two places, leaving a minimum of 0.125 inch gap.
4. Cut jumper J2-B in two places, leaving a minimum of 0.125 inch gap.

Inactive Block of Close Feature

If the Block of Close feature is to remain inactive, follow the procedure below:

1. Cut jumper J2-B in two places, leaving a minimum of 0.125 inch gap.
2. Cut jumper J2-A in two places, leaving a minimum of 0.125 inch gap.

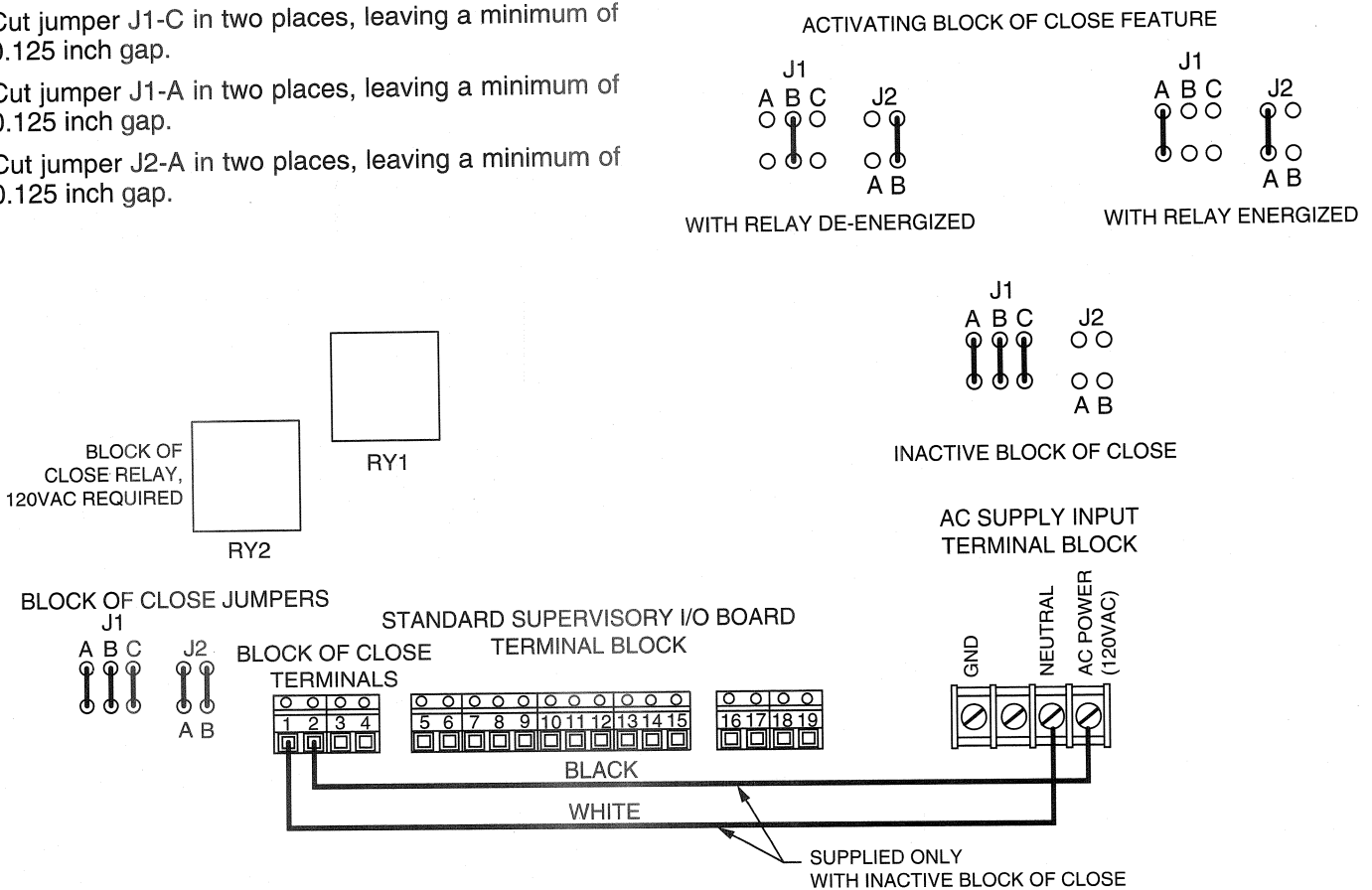
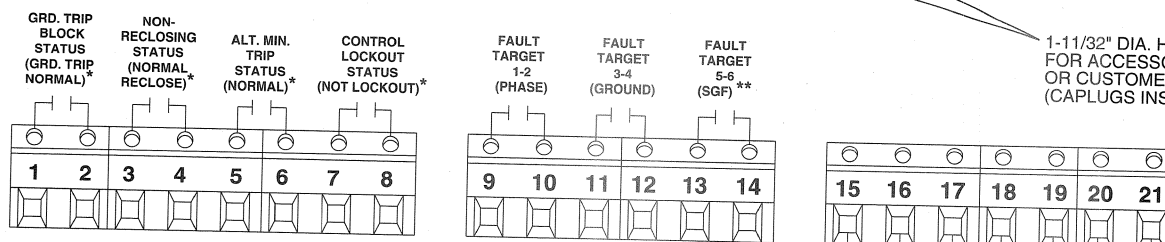
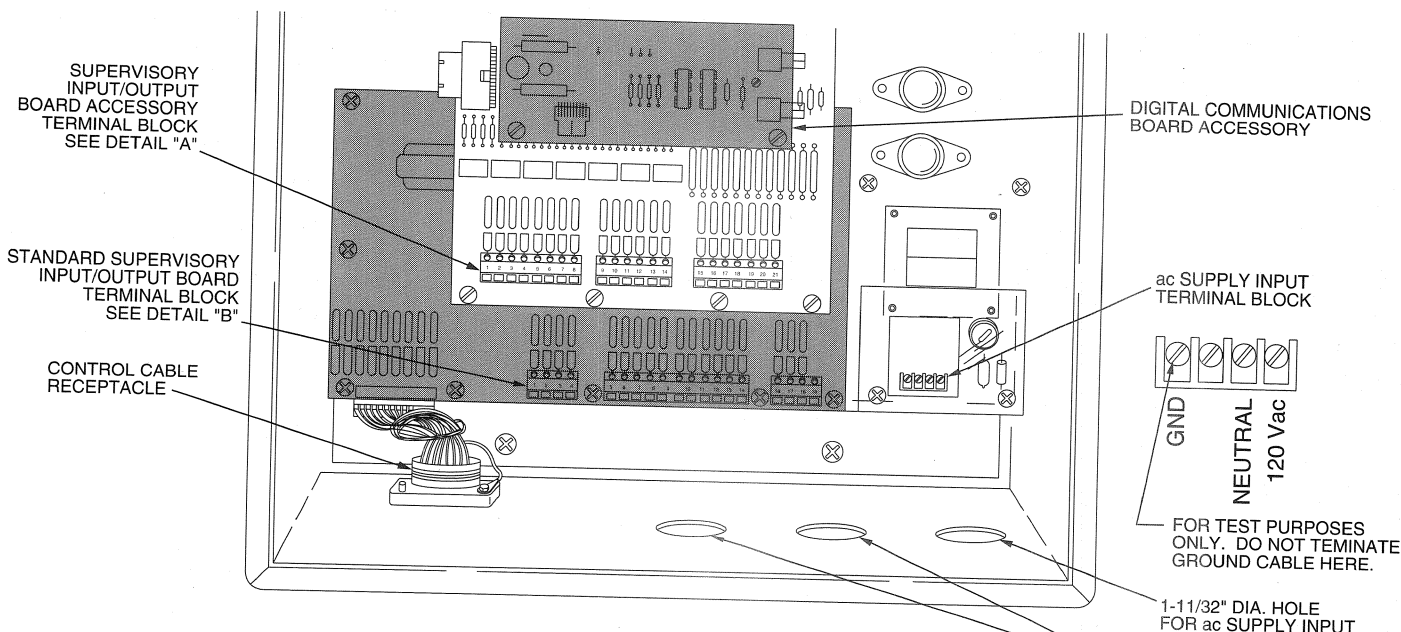
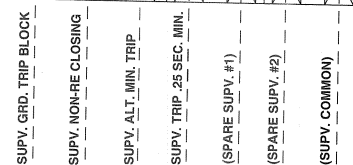

Figure 15. Wire Connection Diagram for Block of Close feature on the Standard Supervisory Input/Output Board.



DETAIL "A"
SUPERVISORY I/O ACCESSORY
TERMINAL BLOCK

** TARGET DESIGNATION WHEN SENSITIVE GROUND FAULT IS ENABLED (ACCESS CODE 120)



VOLTAGE INPUTS

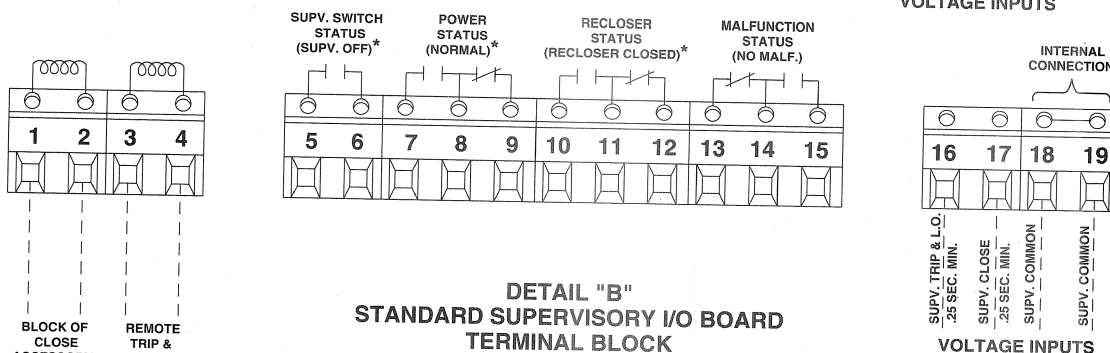

DETAIL "B"
STANDARD SUPERVISORY I/O BOARD
TERMINAL BLOCK

VOLTAGE INPUTS

* RELAY CONTACTS SHOWN FOR THE INDICATED STATUS

Input Voltage	Contact Rating
120Vac	1.0 A
12Vdc	2.0 A
24Vdc	2.0 A
48Vdc	1.0 A
125Vdc	0.6 A

Input Voltage	Nominal Current
120 Vac	8mA
12Vdc	8mA
24Vdc	7mA
48Vdc	5mA
125Vdc	5mA

Input Voltage	Nominal Current
120 Vac	11mA
12Vdc	75mA
24Vdc	37mA
48Vdc	19mA
125Vdc	11mA

Figure 16.
Form 4C Control Customer Connections Diagram.

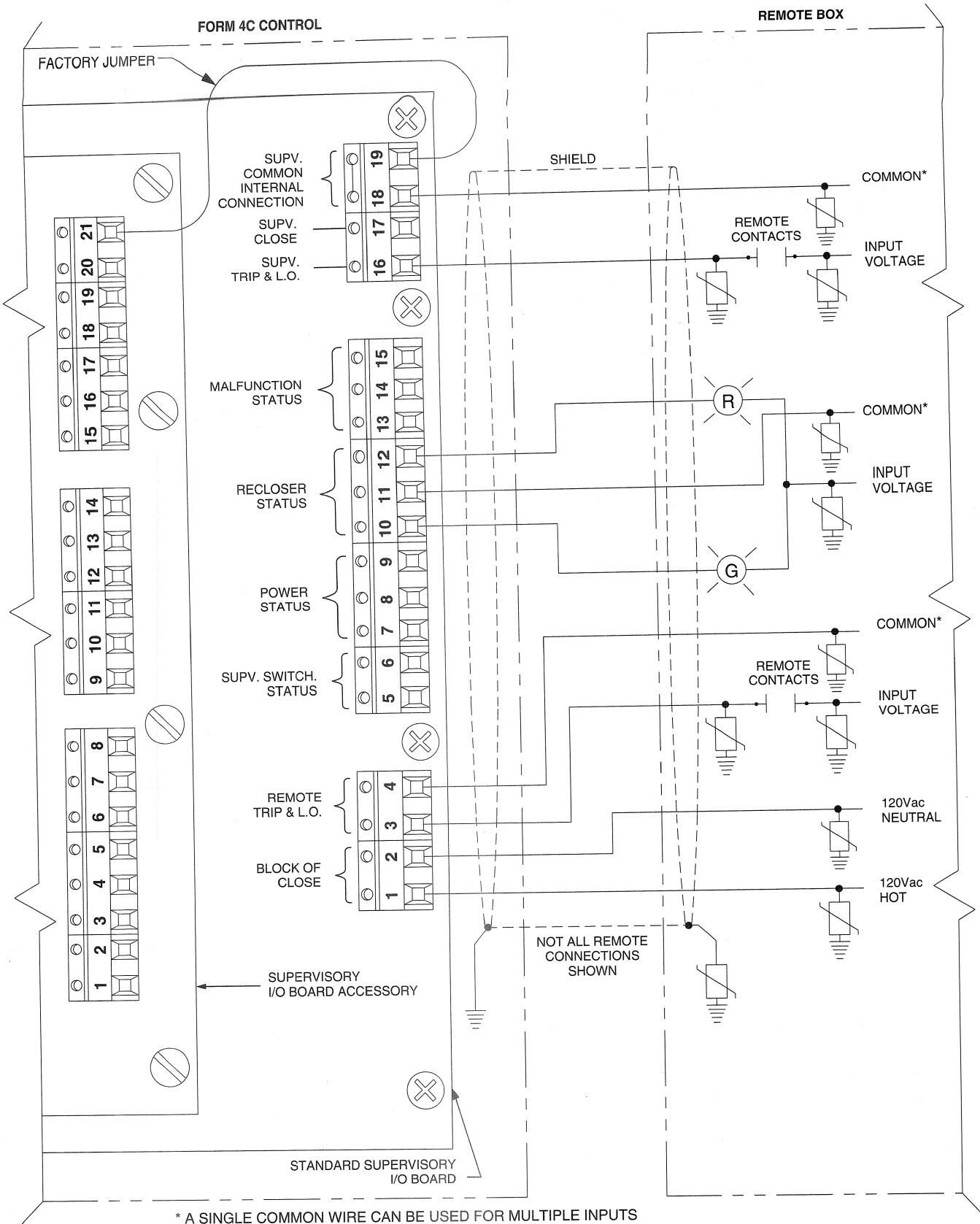

* A SINGLE COMMON WIRE CAN BE USED FOR MULTIPLE INPUTS IF IT IS JUMPERED AT THE I/O BOARD TERMINALS

NOTES: SUPPLY VOLTAGE DEPENDS UPON APPLICATION AND IS CUSTOMER SELECTABLE AT TIME OF ORDER. (OPTIONS AVAILABLE: 12Vdc, 24Vdc, 48Vdc, 125Vdc)

ARRESTERS TO BE METAL OXIDE VARISTORS (MOV'S) 320 Vac, 160 JOULES OR EQUIVALENT

Figure 17.
Shielding and Surge Protection for Supervisory and Remote Cables.



BEFORE PLACING CONTROL AND RECLOSER INTO SERVICE

Prior to placing the control and recloser into service, the following installation procedures must be properly completed and verified.

1. Control properly mounted for the installation.
2. Recloser installed according to all locally approved standards and practices.
3. Control and recloser properly grounded in accordance with guidelines in this manual.
4. Ac power connected to the control (ac Supply LCD indicator is ON).
5. Control battery connected and tested for proper operation.
6. All control programming entered and verified by appropriate personnel.
7. Control clock set to the correct time.
8. Customer connections for remote and supervisory operation checked and completed in accordance with shielding and surge protection instructions in this manual.
9. Control cable properly connected and supported.

TESTING AND TROUBLESHOOTING

CAUTION: Recloser misoperation. The control must be removed from service prior to performing any Level II testing. Failure to comply may result in misoperation (unintentional operation) of the recloser. T216.0

Operation and testing the Kyle Type Form 4C control must be done after the control has been removed from service. This testing and troubleshooting section assists the control operator in:

- Testing the operation of the ac Supply Board and the Control Front Panel.
- Testing the operation of the Standard Supervisory and Accessory Input/Output Boards
- Testing the operation of the Battery Test Panel
- Trip testing of Phases A, B, C, and Ground
- Testing Power and Malfunction Status operation

Level I: Testing an Installed Control

Three tests to determine initial operation of the Form 4C control can be performed while connected to an operating recloser. These are the *only* tests performed on an installed, operating control. All other tests described in the TESTING AND TROUBLESHOOTING section require the Form 4C control be removed from service, connected to a bypassed recloser or tested at a location where the proper testing equipment is available.

Verify The Control is Energized

Open the front panel door of the control. Behind the Ac Supply Input Terminal Block (see Figure 8) is a lamp that, when lit, indicates the control is energized with ac power.

Verify Battery Operation

To test battery operation, follow the procedures described in the *Battery Test Procedure* section of this manual.

Verify LCD Display Operation

From the control front panel (Figure 4):

1. Turn the LCD display ON using the DISPLAY ON/OFF key.
2. Depress the DISPLAY TEST key. The LCD display will show numeric segments and messages.

IMPORTANT: The Form 4C recloser control can be taken out of service for testing and placed back into service without de-energizing its recloser and interrupting the system. However, during the time the control is out of service, the recloser is inoperative.

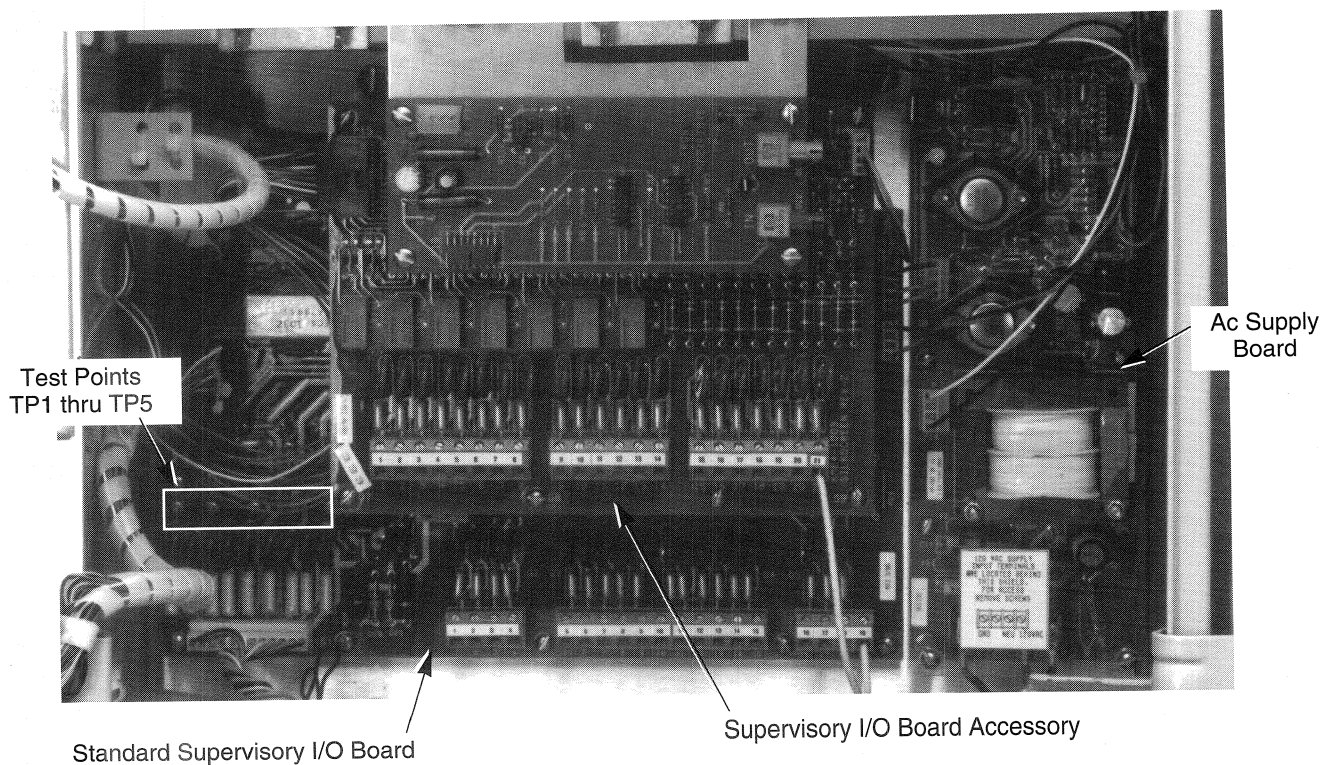

Figure 18. Form 4C Control ac Supply Board, Standard and Accessory Supervisory Input/Output Boards

901023KM-F

Level II: Testing A Control Removed From Service

To Remove Control From Service

For all Level II testing, the following steps must be taken to remove the control from service and prevent possible recloser misoperation.

1. Switch GROUND TRIP BLOCK switch to BLOCK.
2. Disconnect control cable from the control.
3. De-energize ac power from the control.
4. Unplug the control battery.

On an out-of-service control, perform the following steps prior to Level II testing:

1. Ground the control cabinet using the grounding terminal lug (Figures 11 and 12).
2. Energize the ac power to the control.
3. Reconnect the control battery

CAUTION: Control damage. De-energize both ac and dc power prior to removing or installing any internal connections or circuit boards in the control. Failure to comply can result in damage to the control.

T241.1

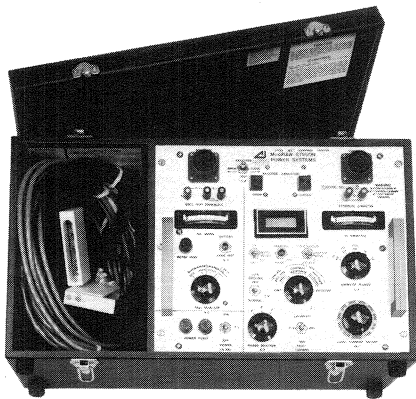

Figure 19.
Kyle Type MET electronic recloser control tester.

89989KM-F

Testing with Type MET Tester

The Kyle Type MET Electronic Recloser Control Tester is used for testing the Form 4C control. The MET Tester is completely self-contained, includes all necessary metering and interconnecting cables, and is capable of performing all required checks and tests from a simple verification of operation to a complete verification of all operating parameters. Operating instructions for the Type MET Tester are contained in *Service Information S280-76-1*.

Testing Control Operation

This section describes testing the status of:

- The front panel containing the computer and display boards
- The ac supply board

The test does not specifically identify the defective component of the boards or panel. The control front panel or circuit boards must be replaced if they are found to be faulty.

Control Fails To Power-Up

If the Form 4C control fails to power-up, either the ac Supply Board, or the control front panel is defective. To isolate the problem, check dc operating power to the control. A voltage test procedure is used to determine which circuit assembly is faulty.

Terminal P11, located on the ac supply board, (Figure 20) contains three test points to verify the status of the board. The proper voltage across each of the three test points of P11 is listed below:

Pin 1 (Black wire)	Zero (battery ground point)
Pin 3 (Blue wire)	33.4Vdc
Pin 4 (Red wire)	24.0Vdc

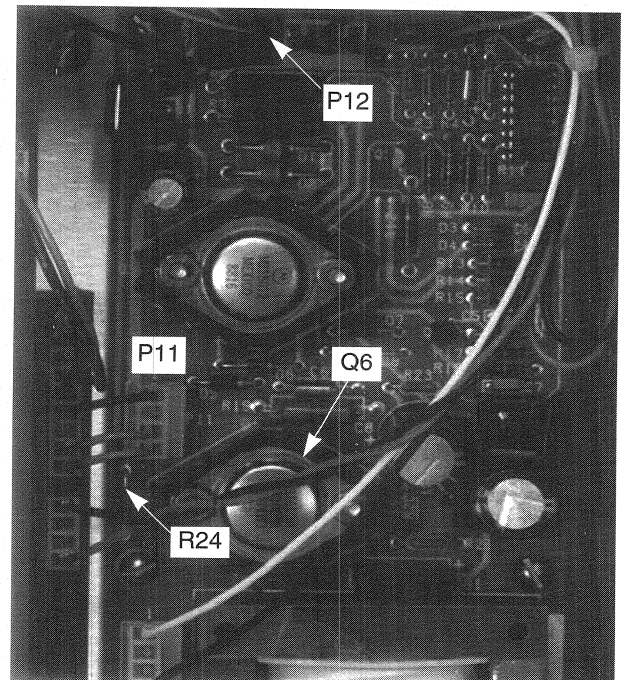

Figure 20.
Upper portion of ac Supply Board.

901023KMA-F

To test the voltages of P11 test points:

Pin 1

1. Using a digital multimeter, place the ground probe against the aluminum plate of the back panel of the control.

NOTE: Keep the ground probe in contact with the aluminum plate for all three dc voltage measurements.

2. Place the positive probe into the pin 1 location (Figure 21).

If Pin 1 does not read zero, the ac supply board is defective and must be replaced.

NOTE: On later model Form 4C controls, resistor R24 was added, connecting pin 1 of P11 to ground. If pin 1 does not read zero voltage, R24 can be defective should be replaced with a new 27 ohm, $\frac{1}{4}$ watt resistor and pin 1 retested again.

Pin 3

3. With the ground probe against the aluminum plate, place the positive probe into the pin 3 location.

If pin 3 does not measure approximately 33.4Vdc, the ac supply board is defective and must be replaced.

Pin 4

The computer and display boards, located in the control front panel, receive dc power from terminal P11-Pin 4 (Red wire). A short circuit in the computer board can cause pin 4 to read a voltage lower than 24Vdc.

If Pin 4 of P11 is not 24Vdc, follow the instructions below:

4. De-energize the ac power and battery power to the control.
5. Disconnect terminal P12 located at the top of the ac supply board.
6. Reconnect ac power.
7. Using a digital multimeter, place the ground probe against the aluminum plate of the back panel of the control.
8. Place the positive probe into the Pin 4 location of P11 (Figure 21).

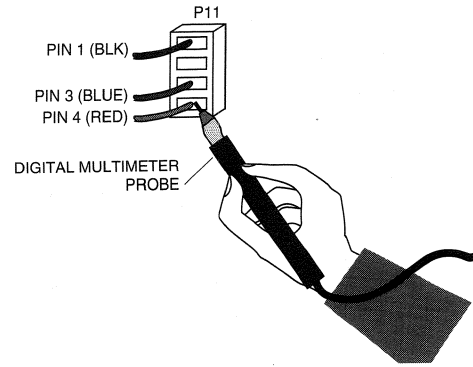

Figure 21.
Testing voltage of P11-Pin 4 on the Ac Power Supply board.

If the power supply measures 24Vdc with terminal P12 disconnected, the computer board is defective and the control front panel must be replaced.

If the power supply is less than 24Vdc with terminal P12 disconnected, the power supply board is defective and must be replaced.

The computer board and the display board are located under an aluminum cover on the inside front panel of the control. These boards must have compatible software versions to operate properly. Therefore, the entire front panel must be replaced if either the computer or display boards is defective. Contact your Cooper Power Systems representative for replacement information.

Test Input Signals of the Standard Supervisory Input/Output Board

The Standard Supervisory and Remote Input/Output Board contains five test points (Figure 22) for checking the input signals to the Form 4C control. The voltages across these test points are proportional to the recloser line current. The output voltages on these test points is 70mV on phase or ground per 100 amps of recloser load current.

Test point designation is as follows:

Phase A = TP1

Phase B = TP2

Phase C = TP3

Ground = TP4

Common = TP5

With 100 Amps of load current applied to the control, test point voltages should read:

TP5 to TP1 = 70mV for Phase A

TP5 to TP2 = 70mV for Phase B

TP5 to TP3 = 70mV for Phase C

TP5 to TP4 = 70mV for Ground

These five test points are provided for simple operation testing of the Form 4C control with a standard 100 watt soldering gun. The gun should have an output voltage of 0.6 Vac minimum.

For accurate test results, the control must be connected to a bypassed recloser, or a Type MET tester (or comparable test set).

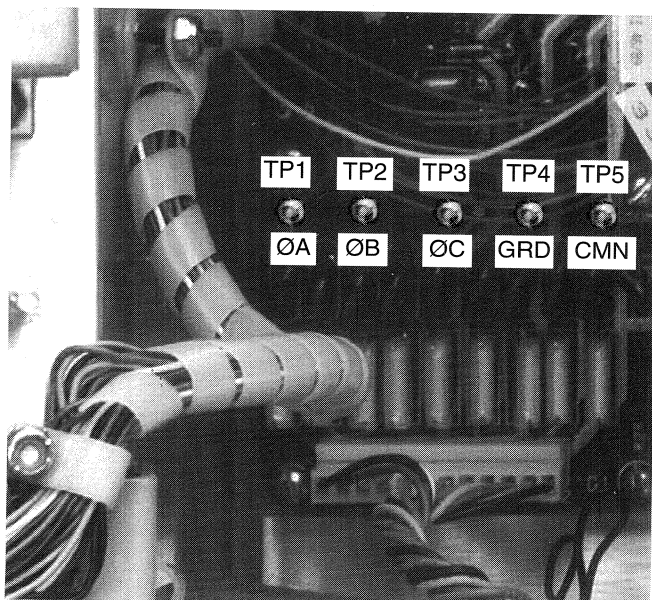

Figure 22.
Test Points on the Standard Supervisory Input/Output board.

901023KMA-F

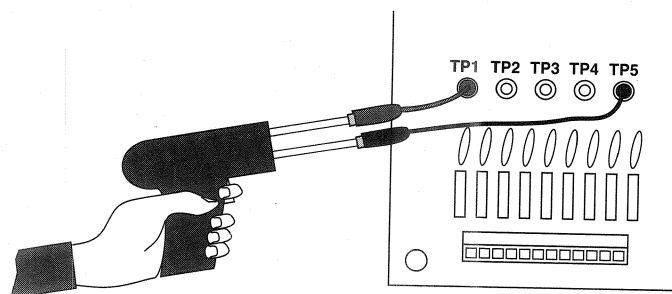

Figure 23.
Soldering gun connected to Standard Supervisory I/O board test points.

Soldering Gun Test

A soldering gun with the proper output voltage of 0.6Vac will send a 700 Amp fault to the control. The control will respond to the fault on its target accessory, and record the fault current on its event recorder for each trip operation. Actual current may vary depending on the soldering gun used. To solder-gun test a control:

1. Set the Non-Reclosing/Normal Reclosing switch to NORMAL RECLOSING and Ground Trip Block switch to NORMAL.
2. Move the Manual Control switch on the control front panel to TRIP, to open the recloser contacts.
3. Remove the tips from the posts of the soldering gun by loosening the hexagonal locking nuts.
4. Clip a short lead to one post of the gun and to test point TP5 (Common). See Figure 23.
5. Clip a short lead from the other post of the soldering gun to test point TP1 (Phase A) See Figure 23.
6. Move the Manual Control switch, on the control panel, to CLOSE. The recloser should close (or the test set simulate a closing operation).
7. Energize the soldering gun by depressing and holding the gun trigger until the recloser trips (or the test set simulates a tripping operation).
8. Immediately after the tripping operation, release the trigger.
9. Repeat Steps 6 and 7 until the control locks out.
10. Count the number of fast and delayed trip operations and compare the count with the control settings.
11. Verify lockout with the LCD control lockout indicator on the operator panel.
12. Repeat this procedure for test points TP2 (Phase B), TP3 (Phase C) and TP4 (Ground).

Testing The Battery Test Panel

IMPORTANT: Battery voltage and charge current measurements made from the test terminals on the battery test panel, can be done while the control is in service as explained in the *Battery Test Procedure* and *Battery Charger Operation* sections of this manual. The control must be taken out of service for all other battery maintenance, battery replacement, battery drain tests, or changes to control parameters.

If the LCD display of the Battery Test Panel does not function when verifying battery status, the battery or the LCD display may be faulty. To diagnose the defective component, connect a voltmeter to the battery test terminals at the right side of the test panel (Figure 24). The required voltage should be 27 to 29 Vdc. Compare the voltmeter reading with the LCD display reading. If different values are read, check to see that the battery is connected properly to the control. If the LCD display still does not read the required voltage rate, the LCD display is faulty and the battery test panel must be replaced.

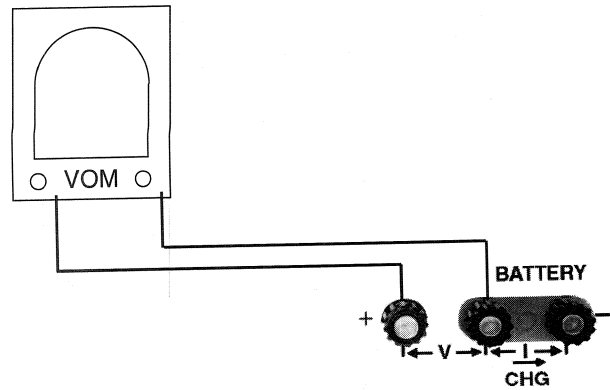

Figure 24.
Testing battery from battery test terminals.

Test Operation of Status Contacts in the Accessory Input/Output Board

The operation of the various status contacts in both input/output boards is verified with an ohmmeter while the contact is changed by operation of the manual operating switches on the lower-front panel of the control. Refer to Figure 25 when testing the terminal blocks of the Input/Output boards.

On the Accessory I/O board (Detail A, Figure 17), customer connection terminals 1 through 14 are used for testing the status contacts of GROUND TRIP BLOCK, NON-RECLOSING, ALTERNATE MINIMUM TRIP, CONTROL LOCKOUT, and PHASE TARGETS A through C. Figure 25 shows the condition of the contacts for each position of the manual control switches located on the front panel.

Testing the Ground Trip Block Status Contact

Connect the ohmmeter probes to terminals 1 and 2.

1. Move the Ground Trip Block switch to the GROUND TRIP BLOCK position. The ohmmeter must indicate a closed circuit across terminals 1 and 2.
2. Move the switch to the GROUND TRIP NORMAL position. The ohmmeter must indicate an open circuit across terminals 1 and 2.

Testing the Non-Reclosing Status Contact

Connect the ohmmeter probes to terminals 3 and 4.

1. Move the Non-Reclosing switch to the NON-RECLOSING position. The ohmmeter must indicate a closed circuit across terminals 3 and 4.
2. Move the switch to the NORMAL RECLOSING position. The ohmmeter must indicate an open circuit across terminals 3 and 4.

Testing the Alternate Minimum Trip Status Contact

Connect the ohmmeter probes to terminals 5 and 6.

1. Move the Alternate Minimum Trip switch to the ALTERNATE MINIMUM TRIP position. The ohmmeter must indicate a closed contact across terminals 5 and 6.
2. Move the switch to the NORMAL position. The ohmmeter will indicate no continuity or an open contact across terminals 5 and 6.

Testing the Control Lockout Status Contact

The control must be connected to either an operating, bypassed recloser; or Type MET tester (or comparable test set). The test set should be ON and no fault current applied.

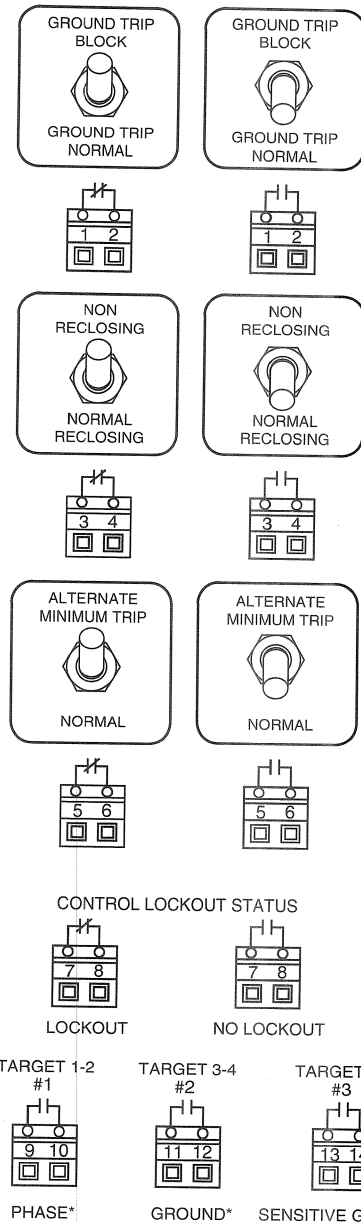

* When Sensitive Ground/Earth Fault is ON (Code 120), target indications change to PHASE, GROUND, and SENSITIVE GROUND/EARTH in place of Phase A, B, and C respectively.

Figure 25.
Verifying operation of status contacts on the Optional I/O Board.

Connect the ohmmeter probes to terminals 7 and 8.

1. Turn the Manual Control switch to the CLOSE position to close the control. An initial reading will indicate no continuity or an open contact across terminals 7 and 8.
2. Turn the Manual Control switch to the TRIP position to lockout the control. The ohmmeter will indicate continuity or a closed contact across terminals 7 and 8.

If the readings from any of these tests do not appear on the ohmmeter as indicated, the Accessory Input/Output board is defective and must be replaced.

Testing Phase Target Status Contacts

The control must be connected to a Type MET tester or comparable test set and a fault generated. A fault is generated by applying any current to the control that is at least 120% above *phase minimum trip*.

1. Set the control so that Access Code 21 (TARGET RESET AFTER SUCCESSFUL RECLOSE) is ON. Refer to *S280-77-4 Form 4C Control Programming Guide* for information on changing access code parameters.

2. Connect the ohmmeter and attach the probes to terminals 9 and 10 for Phase Target 1-2 (Phase A).

The ohmmeter should read no continuity or an open contact across terminals 9 and 10.

3. Simulate a fault current on Phase A. Refer to the appropriate operating instructions for generating current with your test set.

A fault on Phase A results in continuity on terminals 9 and 10.

4 Connect the ohmmeter probes to terminals 11 and 12 for Phase Target 3-4 (Phase B).

The ohmmeter should read no continuity or an open contact across terminals 11 and 12.

5. Simulate a fault current on Phase B.

A fault on Phase B results in continuity on terminals 11 and 12.

6. Connect the ohmmeter probes to terminals 13 and 14 for Phase Target 5-6 (Phase C).

The ohmmeter should read no continuity or an open contact across terminals 13 and 14.

7. Simulate a fault current on Phase C.

A fault on Phase C results in continuity on terminals 13 and 14.

NOTE: Remote indication of targets is altered when the Sensitive Ground/Earth fault feature is ON. The remote targets normally indicate phases A, B, and C (alternatively 1, 2, and 3 - see access codes 17, 18, and 19 in *Programming Guide S280-77-4*), but with Sensitive Ground/Earth Fault feature ON, the remote indications are Phase, Ground and Sensitive Ground/Earth in place of Phase A, B, or C respectively.

Test Operation of Status Contacts in the Standard Supervisory Input/Output Board

On the Standard Supervisory Input/Output board, customer connection terminals 5 through 15 are for testing the status contacts of the Supervisory Switch and recloser, as well as power and malfunction status. Figure 26 shows the condition of the contacts of each function.

To test the Supervisory Switch status contacts, connect the ohmmeter and attach the black and red probes to terminals 5 and 6 on the Standard Supervisory I/O Board.

1. Move the Supervisory switch to the ON position. The ohmmeter will indicate continuity or a closed contact.
2. Move the switch to the OFF position. The ohmmeter will indicate no continuity or an open contact.

To test the recloser status contacts, connect the ohmmeter and attach the red and black probes to terminals 10 and 11.

1. Turn the Manual Control switch to the CLOSE position to close the control. The ohmmeter will indicate no continuity or an open contact on terminals 10 and 11.
2. Connect the ohmmeter probes to terminals 11 and 12. The ohmmeter will indicate continuity or a closed contact on terminals 11 and 12.

If these conditions are reversed, the Standard Supervisory I/O board is defective and must be replaced.

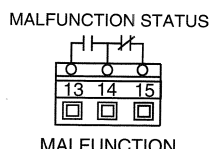
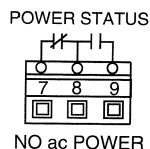
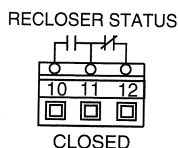
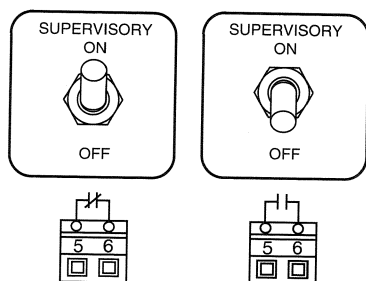

To test the Power status contacts, Connect the ohmmeter and attach the probes to terminals 7 and 8.

1. Energize the recloser control with ac and battery power.
2. Disconnect the ac power. With no ac power, the ohmmeter will indicate continuity or a closed contact on terminals 7 and 8.
3. Connect the probes to terminals 8 and 9. The ohmmeter will indicate no continuity or an open contact on terminals 8 and 9.

If these conditions are reversed, the Standard Supervisory I/O board is defective and must be replaced.

To test the Malfunction status contacts, connect the ohmmeter and attach the probes to terminals 13 and 14.

1. Energize the control with ac and battery power.
2. Disconnect the battery. After a 10 second delay, the malfunction indicator on the front panel will show a malfunction. The ohmmeter will indicate no continuity or an open contact across terminals 13 and 14.
3. Place the probes on terminals 14 and 15. The ohmmeter will indicate continuity or a closed contact across terminals 14 and 15.

Closing The Recloser During Testing

Electrical Closing - Solenoid-Operated Reclosers

Line voltage is required for automatic recloser operation during testing of reclosers equipped with a closing solenoid (except for reclosers equipped with the low voltage closing accessory).

For on-line testing, bypass the recloser, open the load-side disconnects and keep the source-side disconnects closed. This will remove the recloser from service, but will keep line voltage supplied to the closing solenoid (Figure 27).

WARNING: Hazardous voltage. Interconnect source leads X and Y and ground solidly to the recloser tank (Figure 28). Do not connect lead Z to any other phase or mechanical ground. Dangerous voltages to ground exist on the phase connected to lead Z. Solidly ground all equipment. Failure to comply can result in severe personal injury and/or equipment damage.

T224.1

For shop testing, the closing solenoid voltage is supplied by back-feeding a transformer with a low-side rating equal to the voltage rating of an available power source, and a high-side rating equal to the voltage rating of the recloser (Figure 28). A 75kVA transformer of the proper voltage rating with an impedance drop of approximately 3% is satisfactory. The ac source must have a comparable impedance drop.

Figure 26. Verifying operation of status contacts on the Standard I/O Board.

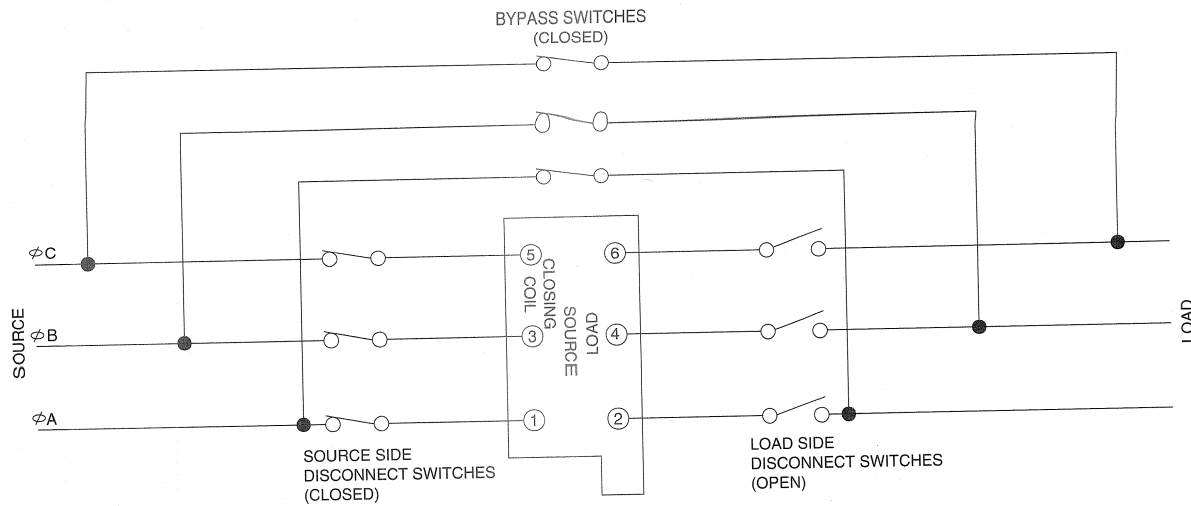

Figure 27. Closing source-side switches of a bypassed “on-line” recloser provides closing solenoid power for automatic operation during testing.

The closing coil requirement is approximately 200kVA during the two-to-three cycle closing operation. The solenoid coil operating voltage must be maintained at the recloser bushings during the cycle interval the closing coil is energized. This procedure is not used on reclosers equipped with the low-voltage closing accessory.

WARNING: Hazardous voltage. The switchgear and high voltage transformer must be in a test cage or similar protective device to prevent accidental contact with the high voltage parts. Solidly ground all equipment. Failure to comply can result in death, severe personal injury, and equipment damage. T221.3

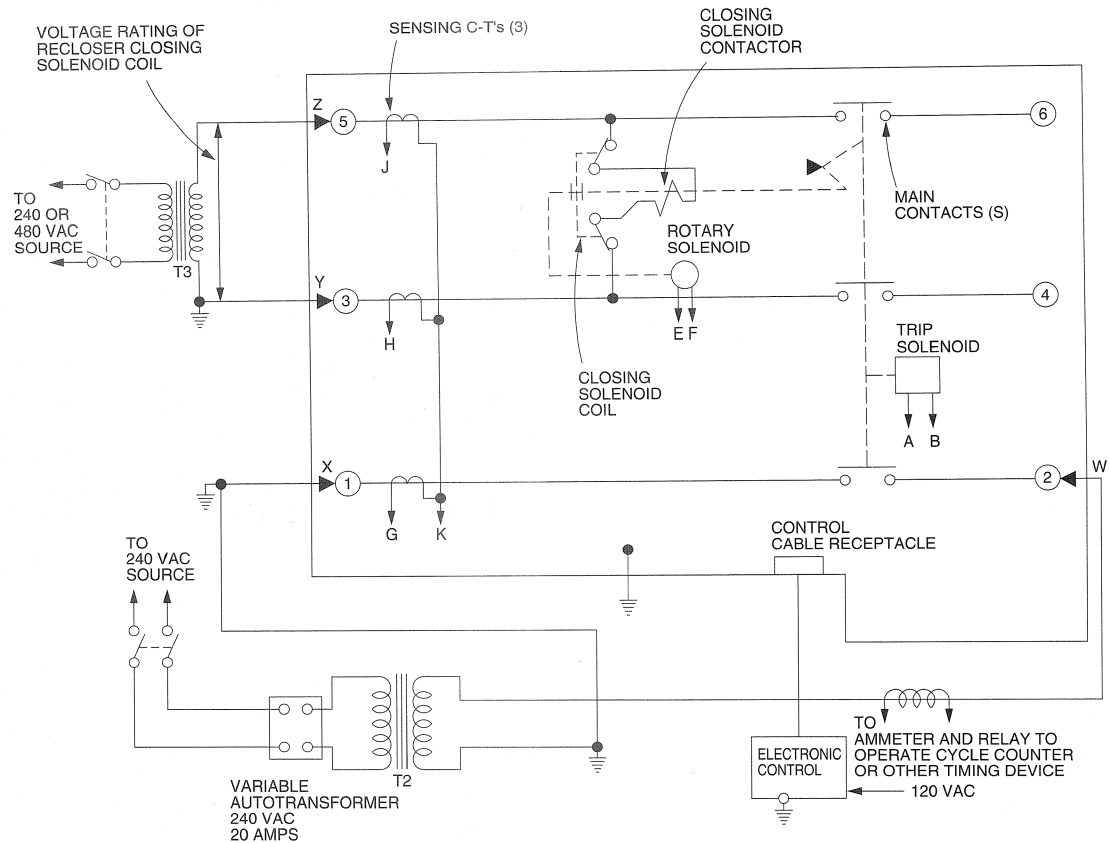

Figure 28. Suggested test circuit for solenoid-closing reclosers.

Electrical Closing - Motor-Operated Reclosers

High-voltage is not required for reclosers utilizing a motor-operated closing mechanism energized from a 230Vac power source. For information on energizing the recloser, refer to the appropriate motor-operated recloser installation manual.

WARNING: Hazardous voltage. Solidly ground all equipment. Failure to comply can result in death, severe personal injury, and equipment damage.

Figure 29 shows a test circuit for motor-operated reclosers. Since these reclosers require only a 240 Vac source for closing, high-voltage transformer T3 and its protective cage is eliminated. All other equipment is the same as the test equipment shown in Figure 28.

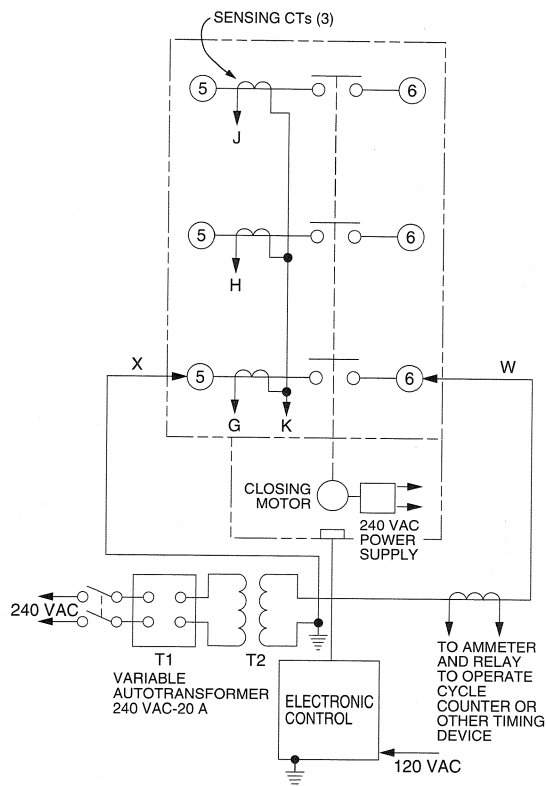

Figure 29.
Suggested test circuit for motor-operated reclosers.

Manual Closing - Solenoid-Operated Reclosers

If high-voltage for operating the closing solenoid is not available, manual closing can be substituted for electrical closing. However, not all control settings can be checked since manual closing is not synchronized with the closing coil control circuit in the control.

IMPORTANT: If manual closing is used during trip testing, the Form 4C control's manual closing must be synchronized with the control's close signal.

If the recloser is not manually closed before the Form 4C control completes its closing signal, the control will go into its close-retry mode.

At this point, if the recloser is manually closed, the control will define the recloser contact position as not valid. The control will trip the recloser and lockout.

WARNING: Hazardous voltage. Excessive Contact Arcing. Do not use the manual closing tool to close an energized recloser. Manually closing an energized oil interrupting recloser can cause excessive contact arcing, rapid build-up of gas within the equipment, and possible explosion. Manually closing a vacuum interrupting recloser could lead to interrupter failure. Explosion or interrupter failure can cause severe personal injury and equipment damage. T203.1

CAUTION: Equipment damage. Do not turn the manual closing tool more than one-quarter turn clockwise. Forcing the tool beyond the mechanism stop may shear the pin on the closing shaft of the recloser. T222.0

To manually close the recloser:

1. Remove the closing tool port cover and gasket from the side of the recloser head casting.
2. Insert the tee-handled tool (available as an accessory) into the port, engaging the pin on the closing shaft (Figure 30).

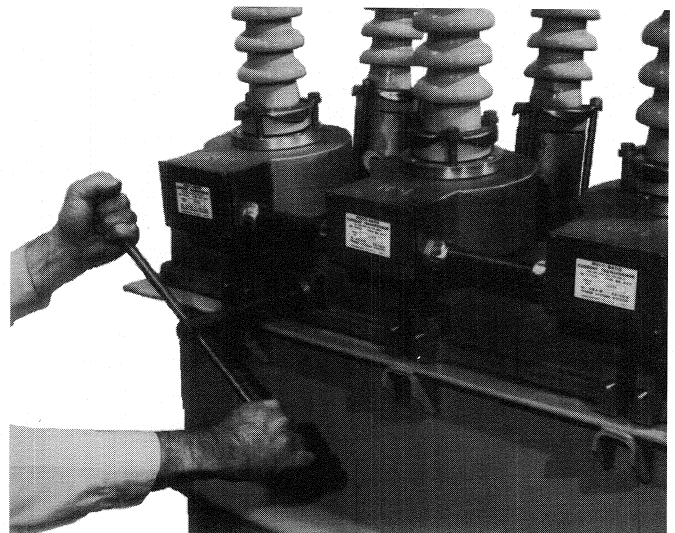

Figure 30.
Using a manual closing tool to operate the recloser.

82284KMA-F

3. Close the recloser by placing the yellow operating handle (located under the sleethood) into the up or CLOSED position and turning the closing tool one-quarter turn clockwise.
4. After each trip operation, about $1/2$ second elapses while the closing solenoid plunger is moving upward to reset the main toggle latch.
5. After the main toggle latch resets, the recloser can be closed again by operating the manual closing tool.
6. Replace the gasket and port cover on the recloser head after testing has been completed.

Return the Control to Service

After the required work is completed, disconnect the control from the test set and follow this procedure to return the control to service:

1. Verify that all control settings are correct.
2. Plug in the control battery.

NOTE: The Form 4C control will not power up until ac power is applied.
3. Apply ac power to the control.
4. Reconnect the control cable to the control.
5. Switch Ground Trip Block switch to NORMAL.
6. Reset the control clock after ac power has been re-applied. (Refer to the *Setting The Control Clock* section of the *Form 4C Programming Guide S280-77-4*.)

MAINTENANCE INFORMATION



CAUTION: This equipment requires routine inspection and maintenance to ensure proper operation. If it is not maintained, it may fail to operate properly. Improper operation may cause equipment damage and possible personal injury.

G105.0

Replacement Kits

Replacement kits for the Kyle Form 4C Control are available through the factory Service Department. To order these kits, refer to the Replacement Parts price list for catalog numbers and pricing. Contact your Cooper Power Systems representative for additional information and ordering procedures.

Factory-Authorized Service Centers

Factory-authorized service centers are located throughout the continental United States to provide maintenance, repair and testing services for Kyle controls and reclosers. For further information, contact your Cooper Power Systems representative.

Factory Maintenance Classes

The factory service department offers a basic testing and troubleshooting course for the Form 4C Microprocessor-based Control and Reclosers. This course, taught by experienced service technicians, is held at the factory's in-house training facility. For additional information, contact your Cooper Power Systems sales representative.

Instructional Video Cassette Programs

Form 4C Control

A video cassette program entitled *KSPV9 Form 4C Microprocessor-Based Control Description and Operation* is available as a supplemental training aid for operating and service personnel.

This video program, developed for use in the factory training school, is used in conjunction with existing service literature. For additional information, contact your Cooper Power Systems representative.

Type MET Recloser Control Tester

A 30-minute video cassette program, *KSPV7 Kyle® Type MET Electronic Recloser Control Tester Operation and Testing Procedures* is available as a supplemental training aid for service personnel.



Appendix I Event Recorder Data Record Sheet

Name: _____

Date: _____ Location: _____

Circuit No.: _____

Control Serial No.: _____ Recloser Serial No.: _____

EVENT 161	Event Type 162	Month/Day 163	Hour/Min. 164	Seconds 165	Ground 166	Phase 1-2 167	Phase 3-4 168	Phase 5-6 169
1								
2								
3								
4								
5								
6								
7								
8								
9								
10								
11								
12								
13								
14								
15								
16								
17								
18								
19								
20								
21								
22								
23								
24								
25								
26								
27								
28								
29								
30								
31								
32								
33								
34								
35								
36								
37								
38								
39								
40								

EVENT TYPE	IDENTIFICATION
1	Overcurrent Trip
2	Reset
3	Close-Manual Control Switch
4	Close-Supervisory
5	Lockout-Manual Control Switch
6	Lockout-Remote
7	Lockout-Supervisory

EVENT TYPE	IDENTIFICATION
8	Trip-Supervisory
9	Loss of AC Voltage (2 minutes minimum)
10	Restoration of AC Voltage (.03 seconds)
11	Sequence Coordination
12	Sensitive Ground/Earth Fault Trip
13	Close Retry Lockout

Appendix II Alternate Minimum Trip Operation

Alternate Minimum Trip Operation vs Supervisory ON/OFF Switch Position

The operation of the ALTERNATE MINIMUM TRIP switch on the front panel of the control and the operation of the Supervisory Alternate Minimum Trip input signal are modified by the position of the SUPERVISORY ON/OFF switch on the front panel.

Supervisory Alternate Minimum Trip is actuated by a customer supplied signal of 12, 24, 48, or 125Vdc or 120Vac for as long as the signal is maintained when Access Code 26 (Supervisory via Momentary Contact) is OFF. This feature is toggled ON or OFF by successive momentary pulses when Access Code 26 is ON. Minimum pulse width duration is 0.25 second.

Tables 2 and 3 show the effect of the SUPERVISORY ON/OFF switch and the ALTERNATE MINIMUM TRIP switch on standard controls and on controls equipped with the accessory supervisory input/output board, which includes the supervisory alternate minimum trip contacts.

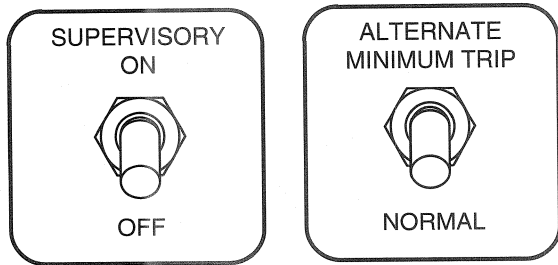

TABLE 2
Minimum Trip Operation Mode on Controls without the Supervisory Input/Output Board Accessory.

Front Panel Alternate Minimum Trip Switch Position	Front Panel Supervisory Switch Position	Minimum Trip Operation Mode
NORMAL	ON	Normal Minimum Trip
NORMAL	OFF	Normal Minimum Trip
ALTERNATE	ON	Alternate Minimum Trip
ALTERNATE	OFF	Alternate Minimum Trip

TABLE 3
Minimum Trip Operation Mode On Controls with the Supervisory Input/Output Board Accessory.

Front Panel Alternate Minimum Trip Switch Position	Front Panel Supervisory Switch Position	Supervisory Alternate Minimum Trip Signal	Minimum Trip Operation Mode
NORMAL	ON	NORMAL	Normal Minimum Trip
NORMAL	ON	ALTERNATE	Alternate Minimum Trip
ALTERNATE	ON	NORMAL	Alternate Minimum Trip
ALTERNATE	ON	ALTERNATE	Alternate Minimum Trip
NORMAL	OFF	NORMAL	Normal Minimum Trip
NORMAL	OFF	ALTERNATE	Normal Minimum Trip
ALTERNATE	OFF	NORMAL	Alternate Minimum Trip
ALTERNATE	OFF	ALTERNATE	Alternate Minimum Trip

Appendix III Non-Reclosing Operation

Non-Reclosing Operation vs Supervisory ON/OFF Switch Position

The operation of the NON-RECLOSING Switch on the front panel of the control and the operation of the Supervisory Non-Reclosing input signal are modified by the position of the SUPERVISORY ON/OFF switch on the front panel of the control. If non-reclosing is activated during the control's operation sequence, the control will not reclose and will immediately go to the lockout state.

Supervisory Non-Reclosing is actuated by a customer supplied signal of 12, 24, 48, or 125Vdc or 120Vac for as long as the signal is maintained when Access Code 26 (Supervisory via Momentary Contact) is OFF. This feature is toggled ON or OFF by successive momentary pulses when Access Code 26 is ON. Minimum pulse width duration is 0.25 second.

Tables 4 and 5 show the effect of the SUPERVISORY ON/OFF switch and the NON-RECLOSING switch on standard controls and on controls equipped with the accessory supervisory input/output board, which includes the supervisory non-reclosing contacts

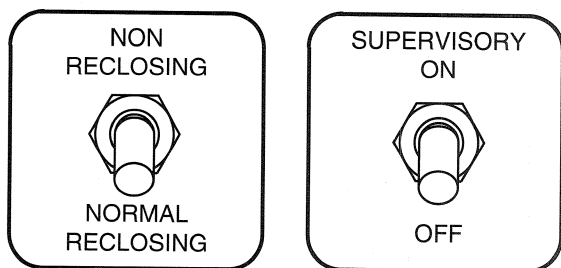

TABLE 4
Reclosing Operation Mode on Controls without the Supervisory Input/Output Board Accessory.

Front Panel Non-Reclosing Switch Position	Front Panel Supervisory Switch Position	Reclosing Operation Mode
NORMAL RECLOSING	ON	Normal Reclosing
NORMAL RECLOSING	OFF	Normal Reclosing
NON-RECLOSING	ON	Non-Reclosing
NON-RECLOSING	OFF	Non-Reclosing

TABLE 5
Non-Reclosing Operation Mode On Controls with Supervisory Input/Output Board Accessory.

Front Panel Non-Reclosing Switch Position	Front Panel Supervisory Switch Position	Supervisory Non-Reclosing Signal	Reclosing Operation Mode
NORMAL RECLOSING	ON	NORMAL RECLOSING	Normal Reclosing
NORMAL RECLOSING	ON	NON-RECLOSING	Non-Reclosing
NON-RECLOSING	ON	NORMAL RECLOSING	Non-Reclosing
NON-RECLOSING	ON	NON-RECLOSING	Non-Reclosing
NORMAL RECLOSING	OFF	NORMAL RECLOSING	Normal Reclosing
NORMAL RECLOSING	OFF	NON-RECLOSING	Normal Reclosing
NON-RECLOSING	OFF	NORMAL RECLOSING	Non-Reclosing
NON-RECLOSING	OFF	NON-RECLOSING	Non-Reclosing

Appendix IV Ground Trip Block Operation

Ground Trip Block Operation vs Supervisory ON/OFF Switch Position

The operation of the GROUND-TRIP BLOCK Switch on the front panel of the control and the operation of the Supervisory Ground Trip Block input signal are modified by the position of the SUPERVISORY ON/OFF switch on the front panel of the control.

Supervisory Ground Trip Block is actuated by a customer supplied signal of 12, 24, 48, or 125Vdc or 120Vac for as long as the signal is maintained when Access Code 26 (Supervisory via Momentary Contact) is OFF. This feature is toggled ON or OFF by successive momentary pulses if Access Code 26 is ON. Minimum pulse width duration is 0.25 second.

The following Tables show the effect of the SUPERVISORY ON/OFF switch and the GROUND TRIP BLOCK switch on standard controls and on controls equipped with the accessory supervisory input/output board which include the Supervisory Ground Trip contacts.

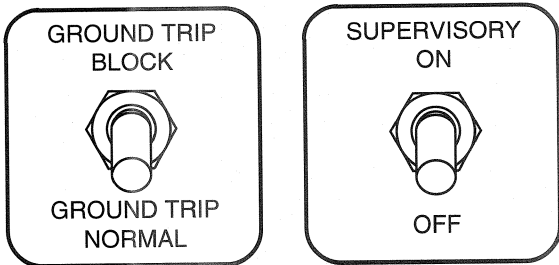

TABLE 6
Ground Trip Operation Mode on Controls without the Supervisory Input/Output Board Accessory.

Front Panel Ground Trip Block Switch Position	Front Panel Supervisory Switch Position	Ground Trip Block Operation Mode
GROUND TRIP NORMAL	ON	Ground Trip Normal
GROUND TRIP NORMAL	OFF	Ground Trip Normal
GROUND TRIP BLOCK	ON	Ground Trip Block
GROUND TRIP BLOCK	OFF	Ground Trip Block

TABLE 7
Ground Trip Operation Mode On Controls with Supervisory Input/Output Board Accessory.

Front Panel Ground Trip Block Switch Position	Front Panel Supervisory Switch Position	Supervisory Ground Trip Block Switch Position	Ground Trip Operation Mode
GROUND TRIP NORMAL	ON	GROUND TRIP NORMAL	Ground Trip Normal
GROUND TRIP NORMAL	ON	GROUND TRIP BLOCK	Ground Trip Block
GROUND TRIP BLOCK	ON	GROUND TRIP NORMAL	Ground Trip Block
GROUND TRIP BLOCK	ON	GROUND TRIP BLOCK	Ground Trip Block
GROUND TRIP NORMAL	OFF	GROUND TRIP NORMAL	Ground Trip Normal
GROUND TRIP NORMAL	OFF	GROUND TRIP BLOCK	Ground Trip Normal
GROUND TRIP BLOCK	OFF	GROUND TRIP NORMAL	Ground Trip Block
GROUND TRIP BLOCK	OFF	GROUND TRIP BLOCK	Ground Trip Block

Appendix V Removal of Control Front Panel Assembly

IMPORTANT: Electro-static discharge. All microprocessor equipment is subject to electrostatic discharge (ESD) damage which can affect programming or result in component degradation or failure.

To prevent possible ESD damage to circuit boards, use the following procedure whenever removing, handling or installing circuit boards:

1. Be sure the control is solidly connected to ground.
2. Use a grounding wrist strap connected to the control ground connection.
3. Always transport and store circuit boards in static-free packaging.

The front panel assembly of the Form 4C control contains all the necessary software for programming the control parameters.

To remove the control front panel:

1. Disconnect the ac power from the control.
2. Disconnect the battery connector found in the upper portion of the inside back panel of the control.

3. Disconnect the front-panel ground strap by removing the #8 nut and lockwasher. Retain these parts for later use.
4. Disconnect the cable plug from socket P7 on the standard supervisory I/O board. Release the cable from the tie-wraps and wire clips.
5. Disconnect the cable plug from the power supply plug P12. Release cable from tie-wraps and wire clips.
6. If control is equipped with the Supervisory I/O board Accessory, disconnect cable plug from socket P15. Release the cable from its tie-wraps and wire clips.
7. Disconnect the cable plug from socket P2 on the top-right corner, on the back of the front panel assembly. Remove and retain the cable clamp and hardware from the cable.
8. Disconnect the front panel's door-stop link. Retain for later use.
9. Remove the panel by lifting it off the slide hinges.

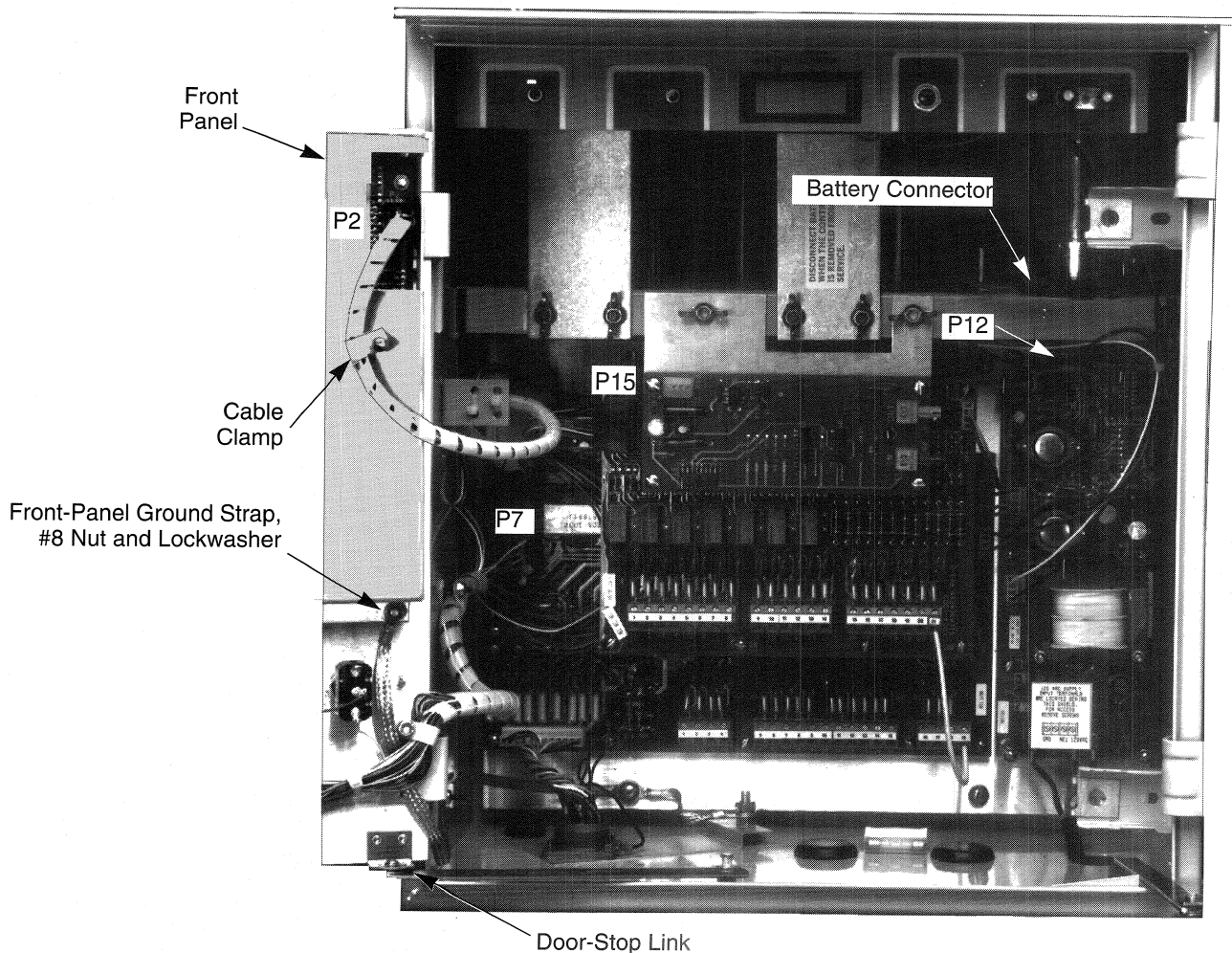

Figure 31.
Removal of the Form 4C control front panel assembly.



Cooper Power Systems

Quality from
Cooper Industries

P.O. Box 2850, Pittsburgh, PA 15230

©1994 Cooper Power Systems, Inc.
Kyle is a registered trademark of Cooper Industries, Inc.