

BE1-79 MULTIPLE SHOT RECLOSING RELAY

The BE1-79 Multiple Shot Reclosing Relay provides automatic reclosure of circuit breakers that have been tripped by a protective relay.

FEATURES

- Up to three reclosure sequences.
- Adjustable reset delay timing (option).
- Discrete or continuously adjustable control of reclosing time delays.
- Programmable instantaneous trip enable contact.
- Light emitting diode (LED) indicators "remember" the number of reclosures.
- Reclose output may be momentary or continuous.
- Automatic reset (option).
- Lockout alarm contact (option).
- Reclose failure alarm contact (option).
- Qualified to the requirements of:
 - ANSI/IEEE C37.90-1978 and C37.90a-1978 for surge withstand capability;
 - IEC 255-5 for impulse.
- Two-year warranty.

APPLICATION

page 2

SPECIFICATIONS

Functional/Electrical
Mechanical Performance
page 3

EXTERNAL CONNECTIONS

Terminals/Diagrams
page 5

ORDERING

Procedure. Accessories.
Style Number Chart.
page 7

INSTRUCTION MANUAL

Reference
Publication Number
9 1368 00 990

SERVICE MANUAL

Reference
Publication Number
9 1368 00 620

INSTALLATION

Case dimensions and
mounting information.
See Bulletin UBY

B Basler Electric
Highland, Illinois

APPLICATION

GENERAL

The BE1-79 Multiple Shot Reclosing Relay is a solid-state device that provides automatic reclosure of circuit breakers that have been tripped by a protective relay. Because many power circuit faults are temporary, the reclosing relay can be programmed to make up to three attempts to re-establish service.

DESCRIPTION

The Basler Multiple Shot Reclosing Relay senses opening and closing of an associated circuit breaker. When the breaker opens, a form b auxiliary contact on the controlled circuit breaker closes. The relay senses this contact closure and, after a pre-programmed interval to allow arcing to dissipate, recloses the breaker. If the fault still exists after the breaker has been reclosed, the relay will make two more attempts at independently pre-programmed intervals. If the fault is still not cleared, and the breaker trips a fourth time, no further attempts will be made to automatically reclose the breaker.

Programming of the individual reclosing intervals is available with either definite time delay steps or continuously adjustable intervals. With the definite time option, the reclosing relay intervals are individually selected on three front panel switches. Each switch has five positions, and covers a range from 0.2 to 60 seconds. With the continuous time option, the reclosing intervals are individually set from three front panel controls and the associated three-position range switches which provide a continuous adjustment range of 0.2 to 60 seconds.

A disable function is provided in the reclosing relay to inhibit the automatic reclosing function. When an external contact connected to the relay's disable input is closed, the relay ignores any breaker tripping action and no reclosing is attempted.

Options are available to provide either isolated or non-isolated contact sensing, to enable instantaneous breaker tripping for any trip, to initiate a remote alarm when the reclosure attempt is unsuccessful (the breaker does not close), and to reset the relay when a reclosure is not followed by a trip for a programmed interval.

SPECIFICATIONS

FUNCTIONAL DESCRIPTION

The specifications on these pages define the many features and options that can be combined to exactly satisfy any application requirement. The block diagram, Figure 1, illustrates how the various standard features, as well as the options, function together.

INPUTS

Breaker Sensing Input

The breaker sensing input requires a 52b (circuit breaker auxiliary) contact rated 0.1 A at 250 Vdc. When closed, this contact signifies that the controlled breaker is open.

When non-isolated contact sensing is provided, the input is polarity sensitive and requires the following:

24 to 60 Vdc at a burden of 3.5 W for a type B power supply,

62 to 150 Vdc at a burden of 4.5 W for a type C

power supply,

12 to 32 Vdc at a burden of 2.0 W for a type D power supply,

and

140 to 280 Vdc at a burden of 7.5 W for a type X power supply.

Disable Sensing Input

The disable sensing input requires a user supplied contact rated 0.1A at 250 Vdc. When closed, this contact will inhibit the automatic reclosing of the relay. The inhibit condition will continue until the contact is opened and the controlled breaker is closed.

When non-isolated contact sensing is provided, the input is polarity sensitive and requires the same voltage and burden allowance given above for the breaker sensing input.

SPECIFICATIONS (Continued)

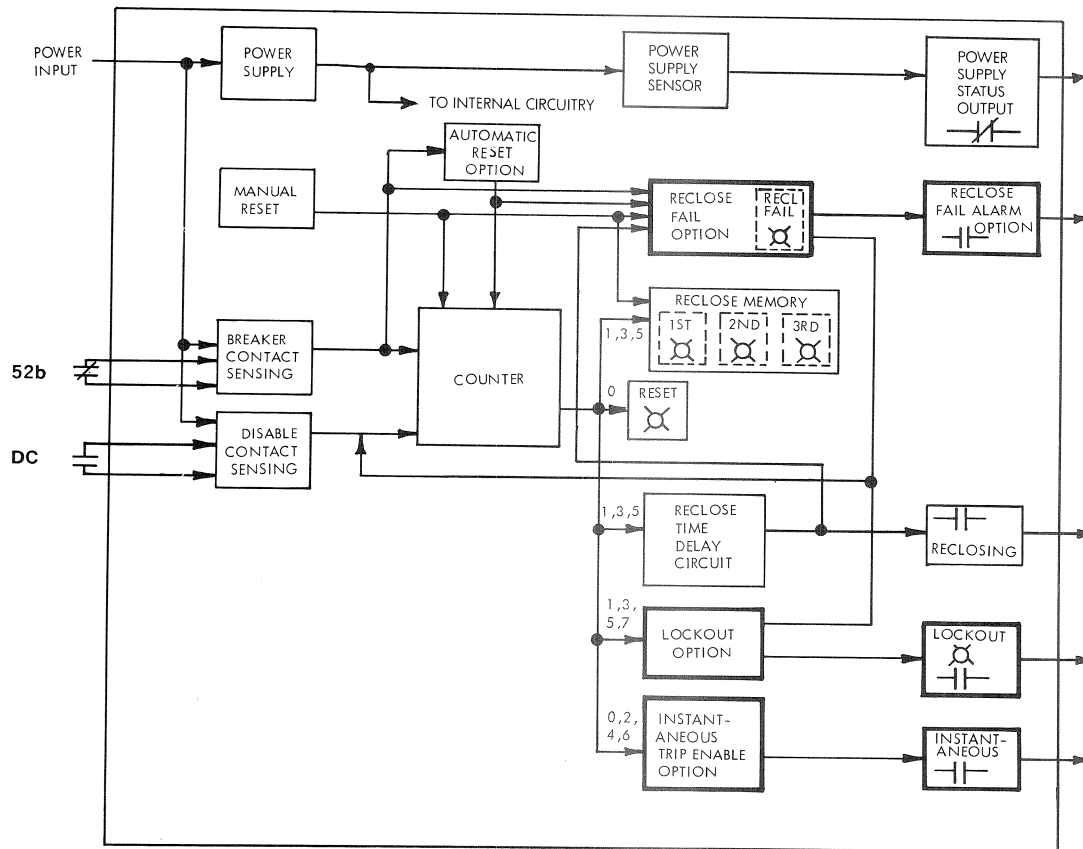

FIGURE 1 – FUNCTIONAL BLOCK DIAGRAM

Power Supply

One of four power supply types may be selected to provide internal operating power. They are described in Table 1.

TABLE 1 – POWER SUPPLY OPTIONS

Type	B	C	D	X (2)
Nominal Voltage	48 Vdc	125 Vdc 100/120 Vdc	24 Vdc	250 Vdc 230Vdc
Burden	4.9 W	6.7 W 11.3 VA	3.8 W	5.8 W 11.6 VA

NOTES:

1. All references are at 50/60 Hz.
2. Relays containing Type X power supply require external sensing input module.
3. Burden ratings are for relay in tripped condition.

COUNTER

The counter is initially reset to a count of 0 when the breaker remains closed for the duration of the automatic reset interval or when the relay is manually reset. Each successive change of state from the breaker contact sensing input advances the counter. Counts of 1, 3, and 5 start the reclose time delay circuit. Counts of 2, 4, and 6 start the reset timer. A count of 7 disables

the relay until it is manually reset or the breaker has been closed by other means for the period of the reset timer.

RECLOSE MEMORY

The reclose memory “remembers” the counts 1, 3, and 5 from the counter and illuminates light emitting diodes (LEDs) 1ST, 2ND, and 3RD respectively on the relay front panel. The memory stores the maximum number of reclosing operations occurring in a reclosing sequence until the relay is reset.

OUTPUTS

Output contacts are rated as follows:

Resistive

- 120/240 Vac - Make 30 A for 0.2 seconds, carry 7 A continuously, break 7 A.
- 250 Vdc - Make and carry 30 A for 0.2 seconds, carry 7 A continuously, break 0.1 A.
- 500 Vdc - Make and carry 15 A for 0.2 seconds, carry 7 A continuously, break 0.1 A.

SPECIFICATIONS (Continued)

Inductive

120/240 Vac, 125 Vdc, 250 Vdc — Break 0.1 A (L/R = 0.04)

POWER INDICATOR

A front panel light emitting diode (LED) illuminates to indicate that the power supply is providing nominal operating voltages to the relay circuitry.

RECLOSE TIME DELAY CONTROL

The time delays associated with the reclosing operation may be specified as either continuously adjustable over the range of 0.2 to 60 seconds or as definite times of 0.2, 2, 15, 45, and 60 seconds. The continuously adjustable delay range of 0.2 to 60 seconds is provided as three overlapping ranges, selectable by a three position switch. A control adjusts the specific value within the selected range.

RECLOSE OUTPUT

The reclosing output contact may be specified to provide a continuous closing signal until reset by breaker closure, or a maximum duration of 2 to 3 seconds, or a maximum duration of 5 to 6 seconds, as defined by the style number designation.

MANUAL RESET

Manual reset of the relay is accomplished by momentarily pushing the reset switch to the up position. This action resets the counter to zero; clears the reclose fail option; clears the lockout option, if present, and resets the reclose memory. The reset switch may be activated without removing the relay cover.

LOCKOUT SELECTION

A switch on the relay front panel permits limiting the number of reclosing operations to 0, 1, 2, or 3.

POWER UP RESET

The relay automatically resets when the power to the relay is interrupted and restored.

TIMING ACCURACY

Timing accuracy for both the reset time settings is within $\pm 5\%$ over the specified operating range of temperatures and voltages.

OPTIONS

Automatic Reset

Resets the relay when the breaker remains closed for a preset time. This time is selectable with a front panel switch which provides reset times of 10, 15, 20, 40, and 60 seconds.

Power Supply Status Output

The optional power supply status output relay is energized and its NC output contact is opened when power is applied to the relay. Normal internal relay operating voltage maintains the power supply status output relay in a continuously energized state with its output contact open. If the power supply output voltage falls below the requirements of normal operation, the power supply output relay is de-energized, closing the NC output contact.

Lockout

The lockout option inhibits further reclosure attempts following a breaker trip. A four position switch on the relay front panel selects trips 1 through 4 and prevents reclosure attempts following the selected trip. When the selected trip occurs, the lockout light emitting diode (LED) illuminates, the lockout alarm relay contact is closed, and the counter is inhibited until the relay is reset.

Instantaneous Trip Enable Output

This output is optionally available to enable tripping by a second set of relay functions that provide an alternate source of breaker trip signals. The programming of the contact is controlled by four toggle switches on the relay panel that cause the instantaneous contact to be closed during count 0, 2, 4, and/or 6 for a maximum of four enable periods.

Reclose Failure Alarm Output

The Reclose Failure contact closes when the breaker does not respond to a reclose signal within a specified time. (The specified time is either 2-3 seconds or 5-6 seconds, depending upon whether Option 1 is 2 or 3.) An LED indicates when the contact is closed.

The contact resets (opens) when the BE1-79 relay is reset (either manually or automatically).

SPECIFICATIONS (Continued)

MECHANICAL

Operating Temperature

-20°C (-4°F) to +65°C (+149°F)

Storage Temperature

-50°C (-58°F) to +90°C (+194°F)

Weight

11.75 pounds

Shock

In standard tests, the relay has withstood 15g in each

of three mutually perpendicular axes without structural damage or degradation of performance.

Vibration

The relay has been tested and withstood vibrations of 1.36 G's over the range of 5 to 26 Hz, 0.036 inch displacement over the range of 26 to 52 Hz, and 5 G's over the range of 52 to 260 Hz without structural damage or degradation of performance. This vibration spectrum was applied in each of three mutually perpendicular axes with a sweep time of 5 minutes.

CONNECTIONS

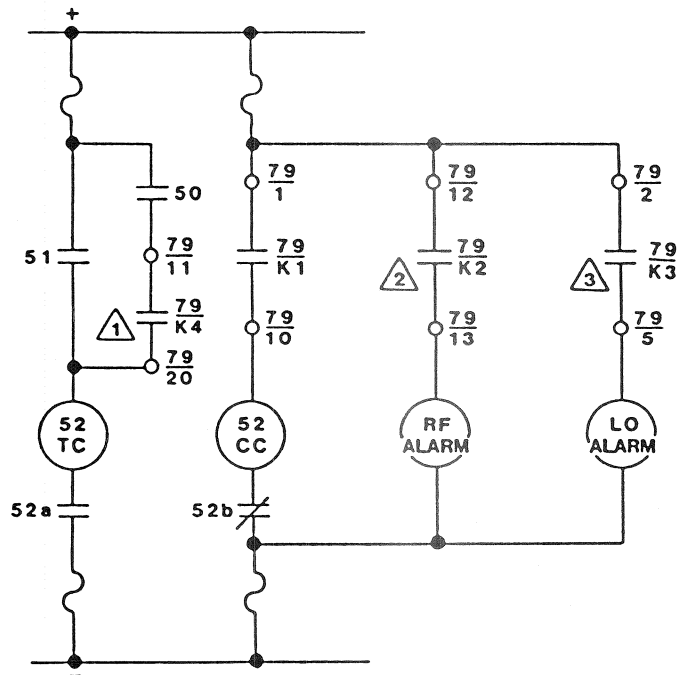

NOTES:

- △1 K4 CONTACTS PROVIDED WITH INSTANTANEOUS TRIP ENABLE OPTION.
- △2 K2 CONTACTS PROVIDED WITH RECLOSE FAILURE ALARM OPTION (NO), OR WITH POWER SUPPLY STATUS OPTION (NC).
- △3 K3 CONTACTS PROVIDED WITH LOCKOUT OPTION.

LEGEND:

- | | |
|------------------------------------|-------------------------|
| 50 INSTANTANEOUS OVERCURRENT RELAY | CC BREAKER CLOSING COIL |
| 51 TIME OVERCURRENT RELAY | TC BREAKER TRIP COIL |
| 52 POWER CIRCUIT BREAKER | DC DISABLE CONTACTS |
| 79 RECLOSING RELAY | ~ FUSE |
| 52a BREAKER AUXILIARY CONTACTS | RF RECLOSE FAILURE |
| 52b BREAKER AUXILIARY CONTACTS | LO LOCKOUT |

FIGURE 2. OUTPUT CIRCUIT CONNECTIONS

CONNECTIONS (Continued)

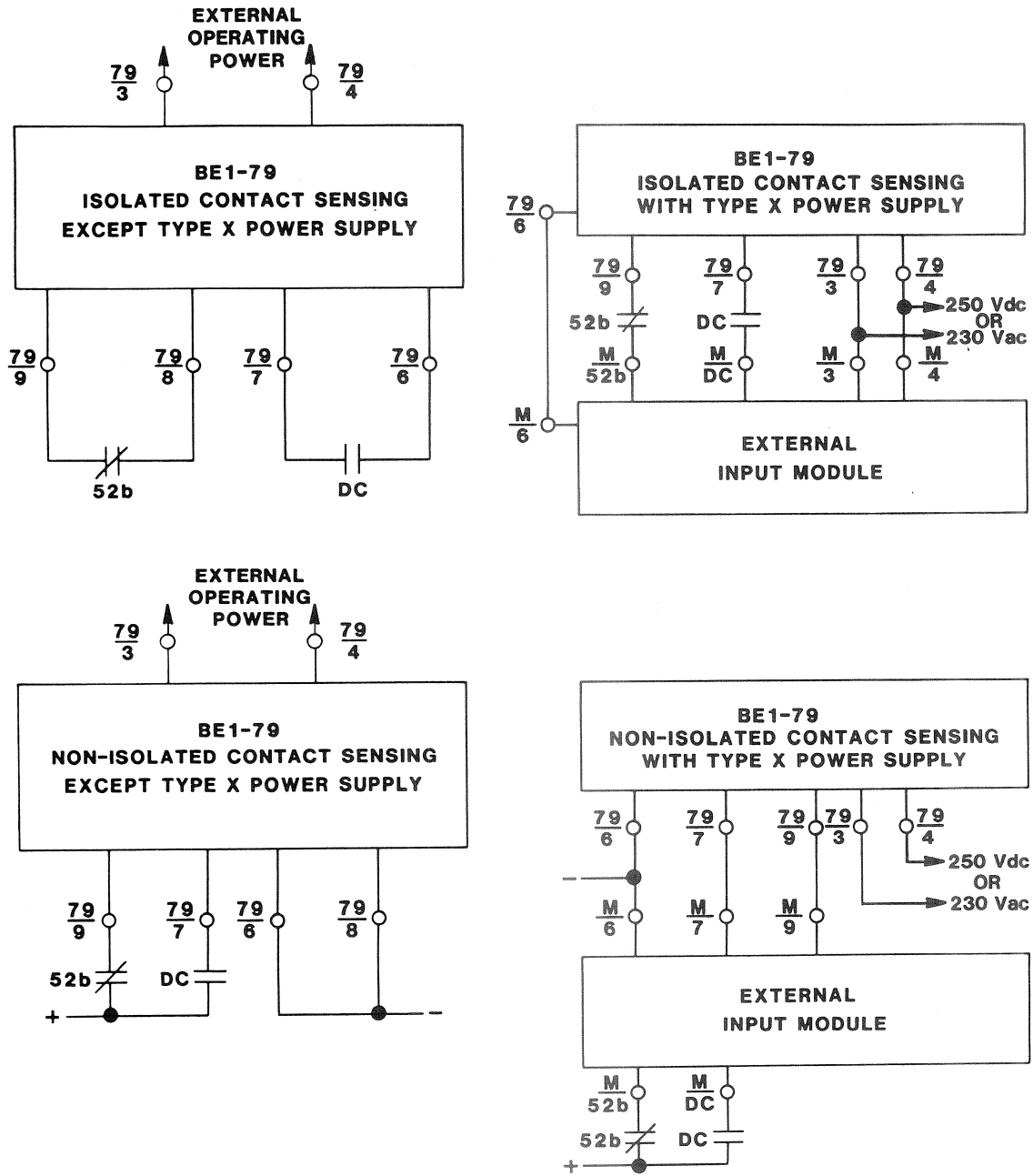

LEGEND:

- 52b** BREAKER AUXILIARY CONTACTS
- DC** DISABLE CONTACTS
- 79** RECLOSING RELAY
- M** SENSING INPUT MODULE

FIGURE 3. INPUT CIRCUIT CONNECTIONS

ORDERING

MODEL NUMBER

BE1-79 Multiple Shot Reclosing Relay

STYLE NUMBER

The style number appears on the front panel, drawout cradle, and inside the case assembly. This style number is an alphanumeric combination of characters identifying the features included in a particular unit. The sample style number below illustrates the manner in which the various features are designated. The Style Number Identification Chart (page 8) defines each of the options and characteristics available for this device.

SAMPLE STYLE NUMBER A1A A5C A2M1F

The style number above describes a BE1-79 Multiple Shot Reclosing Relay having the following features:

Type (A) Multi-Shot

- Lockout and Reset (1) Lockout and Reset circuits
- Instantaneous Trip Enable (A) Selectable
- Reclosure Time Delay (A5) Continuously adjustable from 0.2 to 60 seconds
- Power Supply (C) 125 Vdc, 100/120 Vac external operating power
- Reset Timer (A) Adjustable from 10 to 60 seconds
- Option 1 (2) Maximum reclose signal of 2-3 seconds (non-adjustable)
- Option 2 (M) Isolated contact sensing
- Option 3 (1) Reclosure fail alarm
- Option 4 (F) Semi-flush mounting

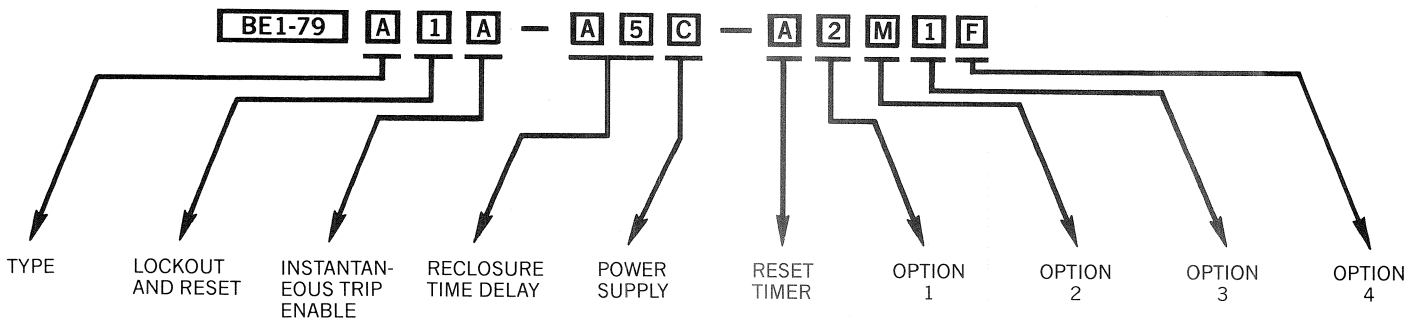

SAMPLE STYLE NUMBER ILLUSTRATED

HOW TO ORDER:

Designate the model number followed by the complete style number:

BE1-79, Style Number -

Complete the style number by selecting one feature from each column of the Style Number Identification Chart and entering its designation letter or number in the appropriate square. (Two squares are used to indicate reclosure time delay.) All squares must be completed.

STANDARD ACCESSORIES:

The following standard accessories are available for use on the Multiple Shot Reclosing Relay.

TEST PLUG:

Order Test Plug, Basler part number 10095.

EXTENDER BOARD:

The Extender Board will permit troubleshooting of the PC. boards outside the relay cradle. Order Basler part number 9 1655 00 100.

MODEL NO.

BE1-79

A

—

—

STYLE NUMBER IDENTIFICATION CHART

TYPE
A) Multi-shot

INSTANTANEOUS TRIP ENABLE
N) None
A) Selectable

POWER SUPPLY
D) 24 Vdc
B) 48 Vdc
C) 125 Vdc 100/120 Vac
X) 250 Vdc 230 Vac ¹

RESET TIMER
N) None
A) Time Delay Adjustable from 10-60 Sec. ³

OPTION 1
O) Continuous Reclose Signal Until Breaker Closes
2) Maximum Reclose Signal 2-3 Sec. (Non Adjustable)
3) Maximum Reclose Signal 5-6 Sec. (Non Adjustable)

OPTION 2
L) Non-Isolated Contact Sensing Input
M) Isolated Contact Sensing Input

OPTION 4
F) Semi-Flush Mounting
P) Projection Mounting

LOCKOUT AND RESET
O) None
1) Lockout and Automatic Reset Circuits
2) Automatic Reset Circuit
3) Lockout Circuit

RECLOSE TIME DELAY
A1) Definite Time Switch 0.2, 2, 15, 45, 60 Sec.
A5) Continuously Adjustable 0.2-60 Sec.

OPTION 2	CONTACT SENSING MODULE
L	9 1463 01 105
M	9 1463 01 104

NOTES:

¹ WHEN THE POWER SUPPLY IS "X" AN EXTERNAL CONTACT SENSING MODULE IS REQUIRED.

2) ALL RELAYS ARE SUPPLIED IN AN "S1" SIZE CASE.

³ IF RESET TIMER IS "A", LOCKOUT AND RESET MUST BE "1" OR "2".

⁴ IF OPTION 3 IS "1", OPTION 1 MUST BE "2" OR "3".

OPTION 3
O) None
1) Reclosure ⁴ Failure Alarm
6) Power Supply Status Output